



GOVERNMENT OF ODISHA  
DEPARTMENT OF WATER RESOURCES

**TENDER DOCUMENT  
(TECHNICAL BID)  
(COVER-I)**

**FOR THE WORK**

**Improvement to Right Service Bank Road of Sapua Link Channel from RD  
2.100 Km to RD 5.330 Km of Sapua Badjore Irrigation Project.**

**ADDITIONAL CHIEF ENGINEER  
ANGUL IRRIGATION CIRCLE, ANGUL**

**GOVERNMENT OF ODISHA**  
**DEPARTMENT OF WATER RESOURCES**  
**OFFICE OF THE ADDITIONAL CHIEF ENGINEER**  
**ANGUL IRRIGATION CIRCLE, ANGUL, ODISHA**  
Pin – 759143

email : [aceangulirrigationcircle@gmail.com](mailto:aceangulirrigationcircle@gmail.com)

**Government of Odisha “e” PROCUREMENT NOTICE**  
**Bid Identification No. ACEAIC- 02/2026-27**

Sl. No.	Name of work	Cost of Work	Class of Contractor	Period of completion	Date and Time of availability of bid document in the portal	Last date/time for receipt of bid in the portal	Name & Address of the Officer Inviting Bid
01	Improvement to Right Service Bank Road of Sapua Link Channel from RD 2.100 Km to RD 5.330 Km of Sapua Badjore Irrigation Project.	Rs.253.32 lakh	“A” & “B”	08(Eight) Calendar Months including rainy season	23.06.2026 at 10.00 AM	07.07.2026 up to 5.30 PM	Additional Chief Engineer, Angul Irrigation Circle, Angul

Further details can be seen from the e-Procurement Portal <http://tendersodisha.gov.in>.  
Any corrigendum/ addendum/cancellation will be displayed in the **Govt.Website only**.

# CONTENTS

SECTION	ITEMS	PAGE NO.
SECTION-1	NIT & DETAILED TENDER CALL NOTICE	04-20
SECTION-2	INFORMATION & INSTRUCTION TO TENDERERS	21-34
SECTION-3	GOVERNMENT GUIDELINES	35-51
SECTION-4	GENERAL RULES AND DIRECTIONS	52-56
SECTION-5	CONDITION OF CONTRACT	57-89
SECTION-6	TECHNICAL SPECIFICATIONS	90-163
SECTION-7	FORMS	164-176
SECTION-8	DRAWINGS	177-179

# **SECTION-1**

**NOTICE INVITING TENDER (N.I.T.)**

**&**

**DETAILED TENDER CALL NOTICE**



**GOVERNMENT OF ODISHA**  
**DEPARTMENT OF WATER RESOURCES**  
**OFFICE OF THE ADDITIONAL CHIEF ENGINEER**  
**ANGUL IRRIGATION CIRCLE, ANGUL, ODISHA**  
pin – 759143 ,email :[aceangulirrigationcircle@gmail.com](mailto:aceangulirrigationcircle@gmail.com)  
**Government of Odisha “e” PROCUREMENT NOTICE**  
**Bid Identification No. ACEAIC- 02 /2026-27**

The Additional Chief Engineer, Angul Irrigation Circle, Angul on behalf of Governor of Odisha invites on-line percentage rate tenders in double cover system through e-procurement for execution of the works noted below. The bid should be submitted by eligible class of contractors as mentioned below registered with State Government & contractors of equivalent grade / class registered with Central Government / MES / Railway to be eventually drawn in P-1 form through On-line in the Govt. website [www.tendersodisha.gov.in](http://www.tendersodisha.gov.in). The bidders should have necessary portal enrolment (with own digital signature certificate). The registered bidders outside Odisha state can also participate in this on-line tender process after necessary portal enrolment but shall have to subsequently undergo registration with appropriate authority of the state government within a month of acceptance of bid. The bidders registered outside the state are required to submit an undertaking in the form of an affidavit, that they are not registered under the GST Act in the state of Odisha as they have not started any business in the state and they have no liabilities under the Act. But, the successful bidder registered outside the state has to produce GST Clearance Certificate in the form GST before signing of agreement.

SL No.	Bid Identification No.	Name of the work	Value of Work (Excluding GST)	EMD/Bid Security (Rs.) (On-line)	Cost of Bid Document (Rs.) (On-line)	Class of Contractor	Period of Completion
1	2	3	4	5	6	7	8
1	ACEAIC-02 /2026-27	Improvement to Canal Service Road of Angul Main Canal from RD 0.00Km to 5.00Km of Derjang Irrigation Project.	Rs. 2,27,23,716/-	2,27,237.00	10,000/-	“A” & “B”	08(Eight) Calendar Months including rainy season
2		Improvement to Approach road to Dam from NH-55 & Balance portion of Dam toe Road (RD 2405 m to 3750m) of Derjang Irrigation Project.	Rs. 2,06,05,380/-	206054.00	10,000/-	“A” & “B”	08(Eight) Calendar Months including rainy season
3		Improvement to Canal Service Road of Khalari distributary in between RD 00 km to 4.00km, Godisahi Minor from RD 0.88 Km to 1.70 Km, Nuagaon Minor in between RD 199m to RD 796m of Derjang Irrigation Project.	Rs. 2,44,21,979/-	244220.00	10,000/-	“A” & “B”	08(Eight) Calendar Months including rainy season
04		Improvement to Canal Service Road of Dangapal Minor from RD 00m to RD 3400m, Aunli main canal from RD 4372m to RD 4656m of Aunli Irrigation Project.	Rs. 2,39,69,034/-	239690.00	10,000/-	“A” & “B”	08(Eight) Calendar Months including rainy season

SL No.	Bid Identification No.	Name of the work	Value of Work (Excluding GST)	EMD/Bid Security (Rs.) (On-line)	Cost of Bid Document (Rs.) (On-line)	Class of Contractor	Period of Completion
1	2	3	4	5	6	7	8
05	ACEAIC-02 /2026-27	Improvement to Right Service Bank Road of Sapua Link Channel from RD 2.100 Km to RD 5.330 Km of Sapua Badjore Irrigation Project.	Rs. 2,53,32,451/-	253325.00	10,000/-	“A” &“B”	08(Eight) Calendar Months including rainy season
06		Improvement of Inspection Road of Left Main Canal from RD 5860m to RD 10290m, Manarbeda Distributary, Belpunji Branch Canal and Tainsar Minor of Manjore Irrigation Project.	Rs. 2,44,28,528/-	244285.00	10,000/-	“A” &“B”	08(Eight) Calendar Months including rainy season
07		Improvement to Barsingha Distributary in between RD 0.00km to 6.25km and Bentapur Minor from RD 0.00km to 1.20km of Derjang Irrigation Project.	Rs.2,68,61,256/-	2,68,613.00	10,000/-	“A” &“B”	08(Eight) Calendar Months including rainy season

2. **E.M.D. & Cost of Tender Document required:** The bidder shall transfer the EMD and Cost of Bid Document On-line as mentioned for the specified work in Column 5&6 in the above table through a process as mentioned in DTCN.
3. **Mode of Submission of Tenders:** Tender should be submitted online in [www.tendersodisha.gov.in](http://www.tendersodisha.gov.in)
4. **Availability of Tender for Online Bidding :** **From 10.00 A.M. of Dt.23.06.2026 to Dt. 07.07.2026 up to 5.30 P.M.**
5. **Date & Time for Opening of Technical Bid :** **Dt.08.07.2026 at 11.30 A.M. in the O/O the Additional Chief Engineer, Angul Irrigation Circle, Angul.**
6. The bid must be accompanied with required **EMD/Bid Security and Cost of Tender Documents** specified for the work in Col. 5 and 6 of the table above through **ONLINE** mode only. The bidder shall transfer the required amount through electronic payment mode like Internet Banking/ NEFT/RTGS of designated banks (SBI/ICICI Bank/HDFC Bank) and their Aggregator Banks as per *Works Dept. Office Memorandum No. 17254 /W Dt.05.12.2017*. Only those bidders who successfully remit the EMD/Bid Security and cost of tender documents on submission of bids would be eligible to participate in the tender/bid process. The bidders with pending or failure payment status shall not be able to submit their bid. The Tender Inviting Authority, State Procurement Cell, NIC, the designated Banks shall not be held responsible for such pendency or failure.
7. The bidders exempted from payment of EMD will be able to participate in the tender directly by uploading EMD Declaration towards their eligibility for such exemption. Schedule Caste/Schedule Tribe Contractors desiring to avail price preference as per relevant Govt. Circulars are required to submit an Affidavit to that effect. The bidders must upload all the documents in **PDF** format.

8. Bid document consisting of qualification, information and eligibility criteria of bidders, plans, specification and schedule of quantities along with rates of the works are available in web-site [www.tendersodisha.gov.in](http://www.tendersodisha.gov.in) and the set of terms and conditions of contract and other necessary documents can be seen in the web-site till last date of availability of tender online for bidding.
9. The bids for the works shall remain **valid for a period of 90 days** from the **last date of receipt of bids**. If any bidder / tenderer withdraws his bid / tender before the said period or makes any modification in the terms and conditions of the bid, the EMD deposited at the time of submission of tender shall stand forfeited.
10. Additional Performance Security (As per Works Department OM No.173 dt.03.01.2026) shall be obtained from the bidder when the bid amount is less than estimated cost put to the tender. In such an event, only the successful bidder who has quoted less bid price / rates than the estimated cost put to tender shall have to furnish the Additional Performance Security as per the following rate.  
Additional performance security shall be taken on an incremental basis from the selected bidder for low bid prices in the project works as under.
- (I) **Where the bid price is below 0% but not below 10% of the project cost put to bid,** no additional performance guarantee/security percentage is required.
- (II) **Where the bid price is below 10% but not below 20% of the project cost put to bid,** the additional performance guarantee/security percentage shall be incremented by 0.1% for every percentage of bid price below 10% of the project cost put to bid starting at 11% with the additional bid performance guarantee being 0.1% and this additional performance guarantee percentage shall be applied on the bid price.
- (III) **Where the bid price is 20% or more below of the project cost put to bid,** the additional performance guarantee percentage shall be incremented by 0.2% for every percentage of bid price below 20% of the project cost put to bid in addition to 1% of the bid price and this additional performance guarantee percentage shall be applied on the bid price.
- (IV) The additional performance guarantee percentage shall be rounded off to the next lower percentage based on whether the decimal point of the percentage of bid price is below 0.5% or next higher percentage based on whether the decimal point of the percentage of bid price is 0.5% or more.
- (V) The additional performance security shall be treated as part of the performance security.
- (VI) Justification for abnormally low bids shall be scrutinized by the Departmental Technical Committee and recommended to the competent authority of the Administrative Department for the approval of the Additional Performance Security (APS). An abnormally low bid is one in which the Bid price, in combination with other elements of the Bid, appears so low that it raises material concerns as to the capability of the Bidder to perform the contract at the offered price. Procuring Entity may, in such cases, seek written clarifications from the Bidder, including detailed price analyses of its Bid price in relation to scope, schedule, resource mobilization, allocation of risks and responsibilities, and any other requirements of the bid document. If, after evaluating the price analyses, the procuring entity determines that the Bidder has substantially failed to demonstrate its capability to deliver the contract at the offered price, the Procuring Entity may reject the Bid/Proposal. However, it would not be advisable to fix a normative percentage below the estimated cost, which would automatically be considered as an abnormally low bid.

If more than one bid is quoted (decimal up to two numbers will be taken for all practical purposes), either at the estimated cost put to tender or less than the estimated cost put to tender, the tender accepting Authority will finalize the tender through a transparent lottery system, where all the concerned bidders/their authorized representatives, the concerned SE/EE of the concerned Division and Divisional Accounts Officer (DAO) will remain present.

If the rate quoted by the SC and ST Category Contractors comes to the rate quoted by the L1 bidder (decimal up to two numbers will be taken for all practical purposes) after availing 10% price preference as per Para 2 of Works Department Resolution No.27748 dated 11.10.1977, the tender shall be finalized by the tender accepting authority through a transparent lottery system along with other categories of contractors.

The Additional Performance Security (APS) shall be in shape of National Savings Certificate/Post Office Savings Bank Account/Post Office Time Deposit Account / Kishan Vikash Patra / Deposit Receipt of any Nationalized/ Scheduled Bank duly **pledged in favour of the Superintending Engineer, Angul Irrigation Division, Angul** within **seven days** of issue of Letter of Acceptance (LoA) by the Division Officer (by e-mail) to the successful bidder otherwise the bid of the successful bidder shall be cancelled. Further proceeding for blacklisting shall be initiated against the bidder. If the APS is submitted in shape of Bank Guarantee by the bidder. then the validity of the Bank Guarantee should be for a minimum period equal to the period allowed for completion of the work plus defect liability period of one year and one month extra for transaction period.

11. The Technical Bid Document consisting of qualification information and eligibility criteria of bidders, plans, specification etc. and the Financial Bid consisting of the Bill of Quantities (BOQ) of works are available in web-site <https://tendersodisha.gov.in> . The bidder must upload scanned copies of valid Contractor Registration Certificate, GST Registration Certificate, PAN card, No Relation Certificate, Affidavit about the authenticity of documents / Bid Security Declaration / price preference, credentials establishing minimum eligibility criteria etc. in **PDF** format otherwise the bid shall be declared as non-responsive & liable for rejection.
12. The Original documents along with a set of its Xerox Copies against the scanned copy of Affidavit, R.C. (Registration Certificate), GST, PAN and other requisite documents submitted through web-site should be produced in the **O/o the Additional Chief Engineer, Angul Irrigation Circle, Angul for verification on demand after opening of the bid.**
13. Other details including details of Portal Registration, Submission of Bid, Resubmission and Withdrawal of Bid can be seen in the bidding document which is available in web-site [www.tendersodisha.gov.in](http://www.tendersodisha.gov.in).
14. Any addendum / corrigendum /cancellation of above tender will be published in the web-site [www.tendersodisha.gov.in](http://www.tendersodisha.gov.in). The system shall generate a mail to those bidders who have already uploaded their tenders and those bidders if they wish, can modify their tenders.
15. **The authority will not be held responsible for any technical problem/failure of network/ Malfunction or Interruption of server during the schedule dates of online bidding.**
16. The on-line bidder shall digitally sign on all statements, documents, certificates uploaded by him owning responsibility for their correctness/authenticity as per IT ACT 2000. If any of the information is found to be false/fabricated/bogus, his/her EMD/Bid Security shall stand forfeited and his/her registration in the portal shall be blocked and bidder is liable to be blacklisted.
17. The bidder should mention his/her valid **E-Mail Address/Phone No.** in the separate sheet for communication regarding the tender. The date of time of the lottery if required will be intimated to the qualified bidders through their valid **E-Mail Id/ Contact Number** provided in the tender website.
18. All the existing provision of OPWD Code with amendment from time to time will be applicable in deciding the tender. All correspondence regarding the tender process will be communicated by **valid E-mail address** provided in the tender website. All bidders are requested to check their E-mail from time to time regarding the tender. No claim whatsoever will be entertained for non-receipt of communication in hard copy.
19. Engineering contractors who are desirous availing the facility of exemption of EMD is required to submit the affidavit in original to the effect that he has not yet availed the facility for more than 02(two) works during the current financial year. Name of the works and authority to whom the tenders has been submitted must be mentioned in affidavit, failing which , the tender will be liable for rejection. However the original registration license of the Engineering contractor should be produced at the time of opening of tender.
20. Amendment to Para 3.5.18 of OPWD code vol-I & rule-29 of Appendix-IX of OPWD code Vol-II “ The single tender received in 1st call shall be cancelled without opening of the bid & fresh tender will be invited “ as per Office Memorandum No. 16 dt. 01.01.2015 of Works Department Govt. of Odisha and as per “ Works Department O.M. No. 16, dt. 01.01.2015 implies that single tender received in the first call shall be cancelled without opening of bid and in case when more than one tender have been received in the first call and only a single tender is found to be responsive, the same is also liable to be cancelled due to lack of competitive price bidding. (Vide Ir. No. 4410 dt. 19.02.2018 of DOWR & Memo no. 4714 dt. 13.02.2018 of the E.I.C. , W.R., Bhubaneswar.
21. Agreement shall be drawn only after due verification of ISD & APS of the successful bidder. If any fake documents are detected , criminal proceedings will be initiated against the defaulting bidder and action will be initiated for black listing through the license issuing authority.
22. Imposition of penalty in EOT/Deviation in case of complete work will be as per the DOWR Lr. No.699 dt. 07.01.2021.
23. **Authority reserves the right to reject any or all the tenders without assigning any reasons thereof. No tenderer can demand the cause of rejection of his offer.**
24. A bidder can submit only one bid for a particular work, submission of more than one bid by a bidder for a particular work will liable for rejection of all such bids.
25. **Name and Address of the Officer Inviting Bids.**

**Additional Chief Engineer,  
Angul Irrigation Circle, Angul ,Odisha-759143,  
email :[aceangulirrigationcircle@gmail.com](mailto:aceangulirrigationcircle@gmail.com)**

-Sd-

CONTRACTOR

Additional Chief Engineer  
Angul Irrigation Circle, Angul

SUPERINTENDING ENGINEER  
ANGUL IRRIGATION DIVISION, ANGUL

**GOVERNMENT OF ODISHA**  
**DEPARTMENT OF WATER RESOURCES**  
**OFFICE OF THE ADDITIONAL CHIEF ENGINEER**  
**ANGUL IRRIGATION CIRCLE, ANGUL**  
**At: Hakimpada, PO-Hakimpada,Dist- Angul – 759143**  
**Odisha**  
**email :[aceangulirrigationcircle@gmail.com](mailto:aceangulirrigationcircle@gmail.com)**

**DETAILED TENDER CALL NOTICE**

- 1.** The Additional Chief Engineer, Angul Irrigation Circle, Angul on behalf of Hon'ble Governor of Odisha, invites on-line **percentage rate** tender for the work “**Improvement to Right Service Bank Road of Sapua Link Channel from RD 2.100 Km to RD 5.330 Km of Sapua Badjore Irrigation Project.**” through website in prescribed form to be eventually drawn on P1 Agreement Form from the Registered contractor of “**A & B Class**” registered under Water Resources, Works and other Departments of Govt. of Odisha. C.P.W.D., Railway or military Engineering Services, Air and Naval or other State Govt., Govt of India, Central Govt. undertakings are also eligible to tender for the work. This invitation for Bids is open to eligible bidders who are registered in the portal. Successful Bidders registered under other state Govt. / CPWD / MES / Railway, Air & Naval has to register under State PWD before signing of the Agreement within a month of acceptance of bid.
- 2.** The tender documents can be downloaded from the website identified as <http://tendersodisha.gov.in> from **23.06.2026 at 10.00 A.M to 07.07.2026 upto 5.30 P.M.** The bidder for participation in online bidding will have to remit online Rs.10,000/-(Rupees ten thousand) only for each set. The Bid will be received through e-procurement portal from **23.06.2026 at 10.00 A.M to 07.07.2026 upto 5.30 P.M.** Each set of bid document contains Technical Bid (Cover-I) and Price Bid (Cover-II) i.e. an intelligent bill of quantity in MS Excel format. The cover-I bid will be opened on **08.07.2026 at 11.30A.M in the O/o Additional Chief Engineer, Angul Irrigation Circle, Angul** in presence of the tenderer or their authorized agents. The bidders who participated in the on-line bidding can witness opening of the bid from any system logging on to the portal away from opening place. The bids can only be opened by the pre-designated officials only after the opening time mentioned in the bid. In the event of the specified date of bid opening being declared a holiday the bid will be opened at the appointed time and location in the next working day.
- 3.** The value of the work tendered for is **Rs.2,53,32,451/-**
- 4.** The bidders shall prepare the documents and upload the scanned typed document in PDF format and BOQ in excel format (or as specified in the portal) in appropriate place.
- 5.** No tenderer will be permitted to furnish their tender in their own manuscript.

## 6. EMD/ BID SECURITY DEPOSIT

(a) The bid must be accompanied with the EMD / Bid Security shall transfer **online** specified for the works in the table Col- 05 above as part of its bid through process as mentioned in the DTCN.

(b) The bids without “EMD / Bid Security” will be summarily rejected. **Engineer contractor** who wants to avail EMD Exemption shall have to furnish scan copy of affidavit. **SC/ST contractors** desires of availing benefit as per Works Department **Resolution No. 16262 dated 30.10.2018 (Item No.1)** must submit affidavit for the same.

Bidders registered as S.C. & S.T. Contractor up to “B” Class desiring to avail concession(s)/ price preference as per prevailing rules should apply for the same in writing in shape of Affidavit and upload necessary document and affidavit in support of their claim along with their bid, failing which their case may not be considered for availing price preference as per the rule. No claim in this regard after opening of the bid will be entertained.

### 1. (a) Providing facilities to the Engineer contractor

i) As per works Department No.FR-11/2001/10003/00 Bhubaneswar dtd 24.5.01, 5% price preference allowed to the Engineer contractor in the tender rates has been withdrawn.

ii) The Engineer contractor shall have to execute the work if awarded to him under his direct supervision and he will not be allowed to execute such work through his Power of Attorney Holder.

(b) Adjustment of earnest money given with other tenders previously and submitted in other tenders shall not be entertained.

(c) Engineering Contractor desirous to avail EMD exemption have to submit affidavit with uploading the same in the e-procurement portal declaring therein to the effect that they have not yet availed 2 (two) nos. of EMD exemption during the financial year 2026-27 and to show the original registration certificate to the tender inviting authority as and when required for confirmation.

### 2. The EMD will be forfeited in any of the following cases.

a) If the bidder withdraws the bid after bid opening during the period of bid validity.

b) If the bidder does not accept the correction of the bid price.

c) In the case of a successful bidder if the bidder fails within the specified time limit to

(i) Sign the agreement or

(ii)Furnish the required performance security.

d) If any of the statements, documents, certificate uploaded by the bidder through e- procurement portal, is found to be false / fabricated / bogus; the bidder will be black listed and his EMD / Bid Security forfeited.

7. For a particular work a bidder can submit only one tender paper. If a bidder submits more than one bid for a particular work through e-Procurement portal the system shall consider only the last bids submitted through portal.

8. The tender is to be submitted in two covers. Cover-I(Technical Bid) which is to contain in pdf form, copy of (i) **Valid Original Contractors Registration Certificate (CDMS)**, (ii) **Valid and active GST Registration Certificate**, (iii) **Original affidavit regarding authenticity of documents**, (iv) **No relation certificate**, (v) **Valid & active PAN Card & (vi) Bid Security /EMD in online mode (vii)All other required documents along with the technical bid duly filled-in as per the relevant clauses of this DTCN & NIT and special conditions if any and Cover-II(Financial Bid)is to contain BoQ in (xls)** and any other special condition if any specifically mentioned by Officer Inviting Tender. During submission of Bids through the e-Procurement Portal, the bidder shall only submit single copy of the document. He is required to check the documents uploaded with the requirement asked for in the bid. Only after satisfying that all the documents have been uploaded, he should activate submit button. His bids shall not be considered responsive and action as per relevant clause shall be taken if he does not provide the required documents or provided illegible document. Clarity of the document may be ensured by taking out a sample printing.

9. The bidder can seek clarification on the bids as per mentioned date to the deadline for submission of bid from the authority inviting tender (AIT) and **Superintending Engineer, Angul Irrigation Division, Angul**. The AIT's response will be forwarded through the e-mail ID of the enquirer.
10. An applicant or any of its constituent partners of whose contract for any work has been rescinded or who has abandoned any work in the last three years having the contracted work is in-complete prior to the date of the bid, shall be disqualified.
11. All charges towards quality control test will be borne by the contractor.
12. The work is to be completed in all respect within 08 (Eight) calendar months from the date of issue of work order.
13. The plans specifications and scope for the work can be seen in the office of the **Superintending Engineer, Angul Irrigation Division, Angul** during any working days.
14. The tenderers shall carefully study the tentative drawings and specifications applicable to the contract and all documents which form part of the agreement to be entered into by the accepted tenderer and detailed specifications for Odisha and other relevant specifications and drawings which are available with the tender document or with the **Superintending Engineer, Angul Irrigation Division, Angul**.

Complaint at a future date that plans and specifications have not been seen by the tenderers can not be entertained.

15. Every tenderer is expected before quoting his rates to inspect the site of the proposed work. He should also inspect the quarries and locality of the work and satisfy himself about the quality and availability of materials including the medical aids, labour and food stuff etc. In every case the materials must comply with the relevant specifications.

The tenderer will be deemed to have Satisfied himself, that the Rates quoted by him in the tender will be adequate to complete the work according to the specifications and conditions attached to and that he has taken into account all conditions, difficulties that may have been countered during its progress and to have quoted labour rates and materials, octroi and other duties, excluding GST but including cess, royalty, lead, lifts, de-lifts loading and unloading and freight for materials and all other charges necessary for the completion of the work to the entire satisfaction of the Engineer-in-charge of the work and his authorized subordinates. Complaints at future date that the availability of materials, labour or any other factor have been misjudged cannot be entertained. It should be understood clearly that no claim whatsoever will be entertained after-wards on the plea of non availability of proper quantity and quality of materials including food stuff or for any other.

16. Each tenderer must quote a definite percentage excess or less up to **two decimal** of the amount of work which will be included in the contract. Tenders containing indefinite terms such as estimated rates or schedules of rates will not be considered. During submission of Bids through the e- Procurement Portal, an intelligent Bill of Quantity in Microsoft Excel format shall be made available to the bidder. The bidder shall fill percentage excess or less of the tender amount and should not leave any cell blank. The line item total in words and the total amount shall be calculated by the system and shall be visible to the bidder.
17. The bidder shall submit the documents in the designated locations of technical bid (Cover-I) and Financial bid (Cover-II). Submission of bid documents shall be effected by using DSC of appropriate class and thus shall

be in encrypted form. The bidder shall only submit single copy of the document. He is required to check the documents uploaded with the requirement asked for in the bid. Only after satisfying that all the documents have been uploaded he should activate submit button. His bid shall not be considered responsive and action as per relevant clause shall be taken if he does not provide the required document or provides illegible documents. Clarity of the document may be ensured by taking out a sample printing.

18. All royalties payable, Income taxes & Surcharges as applicable will be borne by the contractor as admissible. It is implied that the quoted rates are inclusive of such elements.
19. Labour Welfare Cess @ 1% will be deducted from the work bill of the contractor as per resolution No. 12653 dt.15.12.2008 of Labour & Employment Department, Government of ODISHA.
20. Request for raising and lowering the rates or dealing with any point in connection with the tender will not be considered.
21. Conditional tenders will not be taken into consideration.
22. The tender containing extraneous conditions not covered by the tender notice are liable for rejection and quotations should be strictly in accordance with the tender call notice. Any change in the wording will not be accepted.
23. During submission of Bids through the e-Procurement Portal, it is allowed to modify the bid. The bidder shall have to log on to the system and resubmit the documents as asked for by the system including the price bid. In doing so, the bids already submitted by the bidder will be removed automatically from the system and the latest bid only will be admitted. But the bidder should avoid modification of bid at the last moment to avoid system failure or malfunction of internet or traffic jam. If the bidder fails to submit his modified bids within the designated time of receipt, the bids already in the system shall be taken for evaluation. During submission of Bids through the e-Procurement Portal, withdrawal of bid is allowed. The bidder must click on the “withdraw” button and record the necessary justification for the same in the space provided. In addition to this, he must write a letter addressed to the Officer inviting the bid and upload the scanned document to portal in respective bid. The system shall not allow any withdrawal after expiry of the closure time of the bid.
24. On **no account** the contract work should be sublet to anybody without the prior approval of the competent authority of the Department. In such an event the contract may be rescinded with penalty as will be deemed proper as per decision of the competent authority.
25. The e-procurement portal system shall reject submission of any bid through portal after closure of the receipt time. For all purpose the portal time displayed in the system shall be the time to be followed by the bidder.
26. All tenders received will remain valid for 90 days from the last date mentioned for receipt of tenders (online) and validity of tenders can also be extended if required without any monetary compensation.
27. **No Relation Certificate**

The contractor shall have to furnish certificate alongwith the tender to the effect that he is not related to any officer in the rank of an Assistant Engineer and above in the State P.W.D. or Under Secretary and above in the Water Resources Department., If the fact subsequently proved to be false the contract will be rescinded. The earnest money and the total security will be forfeited and shall be liable to make good the loss or damage resulting from such cancellation.

28. While determining the validity of tenders the following points shall be taken into consideration by the authority empowered to accept tenders and his decision in the matter shall be final.

- (a) Any special condition which does not find place in the tender notice and which are not acceptable.
- (b) In definite conditions which will make it difficult for access to the financial implications.
- (c) Tenders being incomplete in some important respects.
- (d) Incomplete schedule of time for completion of the work.
- (e) Failure to furnish the specified bid security.
- (f) Tendered rates being unduly low and unworkable.
- (g) Rates in different items of a tender being irrational.

29. The Department reserves the right of authority to reject any or all tenders received without assigning any reason whatsoever.

30. The tenderer whose tender is selected for acceptance shall within a period of seven days upon intimation being given to him of acceptance of his tender shall sign agreement in the P.W.D. **Form No. P1** for the fulfillment of the contract in the office of the **Superintending Engineer, Angul Irrigation Division, Angul** as directed. The security deposit and the amount withheld according to the provision of P1 agreement shall be retained as security for the due fulfillment of this contract. The written agreement to be entered into between the contractor and the Govt. shall be the foundation of the rights of both the contractor and the Govt. and the contract shall be deemed to be in-complete until the agreement has first been signed by the contractor and then by the proper officer authorized to enter into the contract on behalf of the Govt. The security will be refunded one year after completion of the work and payment of the final bill and will not carry any interest.

31. If more than one bid is quoted (decimal up to two numbers will be taken for all practical purposes) either at the estimated cost put to tender or less than the estimated cost put to tender, the tender accepting authority will finalize the tender through a transparent lottery system, where all bidders / their authorized representatives, the concerned SE/Executive Engineer of concerned Division and DAO will remain present.

The time and venue of the lottery shall be intimated to the respective bidders through their e-mail only. No other communication in this regard will be made.

32. The tenderer whose tender is selected for acceptance shall within a period of seven days upon intimation being given to him of acceptance of his tender make an Initial security deposit @ 2% of the accepted tender amount in shape of NSC /Post Office Savings Bank Account / Post Office Time Deposit Account / Kisan Vikas Patra / Bank Guarantee in favour of **Superintending Engineer, Angul Irrigation Division, Angul** from any Nationalised / Schedule Bank in India counter guaranteed by its local Branch at Bhubaneswar /e-Bank Guarantee executed on the National e-Governance Services Limited (NeSL) Digital Document Execution Portal towards E.M.D./Initial Security Deposit/any other Security Deposit from the Contractor or Supplier and sign agreement in the P.W.D. form No.P1 (Schedule XLV No.61) for the fulfillment of the contract in the office of the **Superintending Engineer, Angul Irrigation Division, Angul, District– Angul,Odisha.**

The security deposit of Initial Security money according to the provision of P1 agreement shall be retained as Security for the due fulfillment of this contract. Failure to enter into the required agreement and to make the security deposit as above shall entail forfeiture of the earnest money. The written agreement to be entered into between the contractor and the Govt. shall be the foundation of the rights of both the contractor and the Govt. and the contract shall be deemed to be incomplete until the agreement has first been signed by the contractor and then by the proper officer authorized to enter into the contract on behalf of the Govt. The bids of the technically qualified bidders will be opened for evaluation of the price bid.

**Additional Performance Security (As per Works Department OM No.173 dt.03.01.2026 & clarification vide Letter No.632 dt.09.01.2026)** shall be obtained from the bidder when the bid amount is less than estimated cost put to the tender. In such an event, only the successful bidder who has quoted less bid price / rates than the estimated cost put to tender shall have to furnish the Additional Performance Security as per the following rate.

Additional performance security shall be taken on an incremental basis from the selected bidder for low bid prices in the project works as under.

- (I) **Where the bid price is below 0% but not below 10% of the project cost put to bid,** no additional performance guarantee/security percentage is required.
- (II) **Where the bid price is below 10% but not below 20% of the project cost put to bid,** the additional performance guarantee/security percentage shall be incremented by 0.1% for every percentage of bid price below 10% of the project cost put to bid starting at 11% with the additional bid performance guarantee being 0.1% and this additional performance guarantee percentage shall be applied on the bid price ;
- (III) **Where the bid price is 20% or more below of the project cost put to bid,** the additional performance guarantee percentage shall be incremented by 0.2% for every percentage of bid price below 20% of the project cost put to bid in additional to 1% of the bid price and this additional performance guarantee percentage shall be applied on the bid price.
- (IV) The additional performance guarantee percentage shall be rounded off to the next lower percentage based on whether the decimal point of the percentage of bid price is below 0.5% or next higher percentage based on whether the decimal point of the percentage of bid price is 0.5% or more.
- (V) The additional performance security shall be treated as part of the performance security.
- (VI) Justification for abnormally low bids shall be scrutinized by the Departmental Technical Committee and recommended to the competent authority of the Administrative Department for the approval of the Additional Performance Security (APS). An abnormally low bid is one in which the Bid price, in combination with other elements of the Bid, appears so low that it raises material concerns as to the capability of the Bidder to perform the contract at the offered price. Procuring Entity may, in such cases, seek written clarifications from the Bidder, including detailed price analyses of its Bid price in relation to scope, schedule, resource mobilization, allocation of risks and responsibilities, and any other requirements of the bid document. If, after evaluating the price analyses, the procuring entity determines that the Bidder has substantially failed to demonstrate its capability to deliver the contract at the offered price, the Procuring Entity may reject the Bid/Proposal. However, it would not be advisable to fix a normative percentage below the estimated cost, which would automatically be considered as an abnormally low bid.

The applicable Additional Performance Security (APS) shall have to be furnished by the successful bidder in shape of Term Deposit Receipt pledged in favour of **Superintending Engineer, Angul Irrigation Division, Angul** / Bank Guarantee in favour of the **Superintending Engineer, Angul Irrigation Division, Angul** from any Nationalised/ Scheduled Bank in India counter guaranteed by its local branch at Bhubaneswar within seven days of issue of Letter of Acceptance (LoA) by the **Superintending Engineer, Angul Irrigation Division, Angul** (by e-mail) to the successful bidder otherwise the bid of the successful bidder shall be cancelled. Further, proceeding for blacklisting shall be initiated against the bidder. (*Vide Office Memorandum No-14459/WE dated.20.09.2018 of Works Department, Govt. of Odisha*).

The security will be refunded after one year on completion of the work in all respect provided the final bill is passed and will not carry any interest. Any defect noticed during the period of one year after the actual date of completion shall be rectified by the contractor at his own cost. Failure to comply such rectification the cost involved to carry out the defective work shall be met from his dues available with Department. (Ref. works Deptt order No.17823/WE dt. 11.10.2006. The e-procurement portal system shall generate the award of the contract letter and intimate the bidder in his e-mail after acceptance of the tender.

33. Before acceptance of tender, the successful bidder will be required to submit a work programme and milestone basing on the financial achievement so as to complete the work within the stipulated time and in case of failure on the part of the agency to achieve the milestone liquidated damage will be imposed.
34. The contractor shall sign as a token of final acceptance of the plans, sections and agreements for the work prior to take up the work for execution.
35. The date of commencement of work shall be as notified in work order.
36. On signing the agreement the site will be handed over to the contractor for execution and completion of works in all respect.
37. The authority reserves the right to make such increase or decrease in quantity of items of works mentioned in the scheduled attached to the tender notice as may be considered necessary for the satisfactory completion of the contract work. All such increase or decrease shall in no way invalidate/vitiate the contract rates. The contractor shall not be entitled for any compensation on this account, except grant of extension of time where considered necessary.
38. The work may be splitted up and distributed among several contractors if considered necessary on the exigency of the circumstances of the work and the contractor is not entitled to any compensation on this account.
39. That for the purpose of jurisdiction in the event of any dispute if any, the contract would be deemed to have been entered into within the State of Odisha and it is agreed that neither party to the contract will be competent to bring a suit in regard to the matter by this contract at any place outside the State of Odisha.
40. Under section-12 of contract labour (Regulation and Abolition Act 1970) the contractor who undertakes execution of work through labour, should produce valid license from licensing authority of labour department (labour license) to start the work.
41. The contractor shall be liable to fully indemnify the Department of any compensation under workmen compensation Act VII of 1993 on account of the workmen employed by the contractor and full amount of compensation paid will be recovered from the contractor. In the event of any claim sub-judice before any court of law, the claim amount shall be kept withheld till final disposal.
42. Contractor is required to abide by the fair wages clauses as introduced by Govt. of Odisha and will not pay less than the Fair wages fixed by Govt. to the labourers engaged by him for the work.
43. In case of any complaint by the labourer about the non payment of his wages as per latest minimum wages Act., the Superintending Engineer will have the right to investigate and if the contractor is found to be at fault,

Superintending Engineer may recover such amount due in any form from the contractor and pay such amount to the labourer directly under intimation to the local labour office of the Govt. The decision of the Superintending Engineer is final and binding on the contractor.

44. The contractor will have to submit the monthly return of labour both skilled and unskilled employed by him on the work site **to the Superintending Engineer, Angul Irrigation Division, Angul,**
45. The contractor should keep himself in touch with the Engineer-in-charge for smooth execution of the work and arrange adequate labour depending on the workload and working space available. No claim for detention for labour on any account will be entertained.
46. No compensation will be paid by the Department for any damage done by rain, flood, cyclone & earthquake tide or by any other natural calamities during the execution of the work.
47. It should be understood clearly that no claim whatsoever will be entertained in regard to extra items of work or extra quantity of any item besides estimated amount, unless written order is obtained from the Engineer-in-charge and rates settled before the extra items of work or extra quantity of any item of work is taken up.
48. The tenderer shall bear various incidentals, sundries and contingencies necessitated by the work in full within the following or similar category.
49. Rent, royalties and other charges of materials & all other taxes including ferry tolls, conveyance charges and other cost on account of land and buildings including temporary building and temporary electric connection to work site as well as construction of coffer dam, construction of service road, diversion road and its maintenance till completion of work required by the tenderer for collection of materials, storage housing of staff other purpose of the work will be paid by the contractor. No tenderer will however be liable to pay for temporary occupation of land owned by Govt. at the site of the work. GST on works contract as applicable at the time of payment of R/A bill shall be paid extra over the gross amount of R/A bill.
50. Labour camps or hutments including conservancy and sanitation arrangements upto the satisfaction of the local health authorities should be arranged by the contractor.
51. Suitable water supply including pipe water supply wherever available for the staff and labour as well as for the work.
52. Fees and duties levied by the municipal canal or water supply authorities.
53. Suitable equipment and wearing apparatus for the labour engaged in risky operations and medical aid to the labourer engaged for the work.
54. Suitable fencing, barriers, signals including paraffin and electric signals where necessary at work and approaches in order to protect public and employees from accident.
55. Compensation including cost of any suit for injury to persons or property due to neglect of any major precautions also become payable due to operation of the workmen compensation Act.
56. The contractor has to arrange adequate lighting arrangement for the work wherever necessary at his own cost.
57. In case of delay in acquisition of land handing over possession of work site no compensation will be admissible but extension of time will be allowed if applied in prescribed format within due time to keep the contract in force.
58. Over and above these conditions including the Technical specifications the terms, conditions, rules and regulations and specifications laid down in I.S.I. code are also binding on the part of the contractor.
59. Deduction of income tax at source and surcharge on income tax will be made from each running account bill for the work at the rate as per Income Tax Act and as amended from time to time. (Present rate 2% + surcharge)
60. (a) The rates quoted by the contractor shall be deemed to be exclusive of GST on all the materials that he will have to purchase for performance of this contract.

61. The rates quoted by the contractor in the tender for works shall exclusive of GST that may be levied on turnover on works contract according to the Laws and Regulations as applicable from time to time.
62. Deduction of GST at source will be made from each running account bill for the work at the rate of 2% prescribed by Odisha Goods & Service Tax Act-2017 or amended from time to time.
63. 1 % (One percent) of the gross amount of the bill will be deducted from the contractor bill towards labour cess as per Odisha building and other construction workers (RE & CS) rules 2002 and Amendment during 2008 and as amended by Govt. from time to time.
64. The amount on royalties of different materials as utilized by the contractor in the work will be recovered from his bill, basing on the rate fixed by the Govt. or as amended from time to time during the period of execution.
65. Schedule of quantity accompanies the tender notice: It shall be definitely understood that the Government do not accept any responsibility for the correctness and completeness of this schedule and this schedule is liable for alternations or omissions, deductions or additions as set forth in the condition of contract and such omissions, deductions, additions or alternations shall in no way invalidate/ vitiate the contract and no extra monetary compensation will be entertained.
66. Sample of stone, metal, chips, sand, cement, moorum etc to be used are to be deposited noting the quarry under dated initial of the tenderer in the Office of the **Concerned SDO, Sapua-Badjore Irrigation Sub-division, Satmile** before the procurement for testing and acceptance. The transportation & testing charges of construction materials will be borne by the contractor.
67. Items of works not covered by the tender notice shall be paid at the current schedule of rates of the State and those not covered by the said schedule of rate will be paid on actual analysis approved by the competent authorities prevailing during the period of execution of work.
68. All preliminary works such as vats, mixing platforms etc are to be done by the contractor at his own cost. No payment will be made for benchmarks, level pillars, profiles, benching and leveling the ground where required. The rates to be quoted should be for finished items of works inclusive of such incidental items of works.
69. After the work is finished all surplus materials and debris's should be removed from 100 Mtr. clear away from the site of the work. Preliminary work such as vats, mixing platforms etc. should be dismantled and all materials removed from the site and premises shall be made neat and clean and this is inclusive of the rates quoted by him.
70. The contractor is to supply necessary labour and materials for the purpose of alignment lying recording of levels whenever required at his own cost.
71. The contractor should arrange necessary tools and plants such as Pumps, Excavator, Trucks, compressors, Tippers, batching plants, Concrete Mixer, steel shutter plates etc. required for the efficient execution work at his own cost. The running charges of such plant and cost of consumables and conveyance are to be borne by the contractor. Any deviation from this may lead recession of contract.
72. In the event of delay in supply of design reasonable extension of time shall be granted on the application of the contractor. But no claim for monetary compensation will be entertained under any circumstances.
73. Under no circumstances, interest is chargeable for the dues or any additional dues, if any payable for the work.
74. An affidavit shall be furnished by the contractor at the time of submission of tender paper about the authentication of tender documents. The scanned copy of the affidavit is to be uploaded through the e-procurement portal along with the technical bid. The affidavit in original is to be produced before the officer inviting tender after opening of the tender positively.
75. Prediction of flood/monsoon Damage:  
The contractor shall make his own arrangement at his cost to shift the machineries, equipment's, materials, labourer and departmental machineries if hired by the contractor to a safe place prior to flood. The work shall have to be resumed after the flood come to normal. No extension of time for the completion of the work may be considered by the Department if the discontinuance of the work is beyond the reasonable attempts of the contractor to such eventualities.
76. The debris, sand and other materials, accumulated in the work area during flood shall be removed by the contractor as required for continuing the work at his own cost. By any chance, if any excavated portion that

could not be filled up with concrete by the contractor, gets filled up during the monsoon period with earth such removal will not be paid again. The contractor will have to re-excavate the same at his own cost.

77. It shall be distinctly understood that it is entirely the responsibility of the contractor to make such arrangements may be required from time to time to protect the men, machinery, materials and the work under progress and work for which the measurements were recorded and payment made, against any damages either during working season or during the flood. The department accepts no liability, what so ever for any damage or loss of men, materials, machinery and type of hindrance caused to the progress of work.
78. The contractor should provide at his own cost adequate protection measures to the completed works at the end of working season or work in progress against such eventuality till completion and handing over the entire work to the Department.
79. Dewatering from the foundation of structures when and where necessary during execution will have to be done by the contractor and no extra payment will be made on that account. The rate of respective items of work is inclusive of the dewatering.
80. The term dewatering shall mean the execution or operation of the items due to standing water as well as due to percolation water.
81. No claim for idle labour etc. on any account will be entertained by the Department.
82. The clause of printed form of **P<sub>1</sub> contract** with latest addition/ deletion/ corrections/ substitution etc. will also be binding.
83. **GENERAL INSTRUCTION TO CONTRACTORS as per DoWR letter No.20415 dt.14.09.2015**

- (a) Any agency or contractor executing a work should be aware about the local festivals like Makar Sankranti, Raja Sankranti , Chaiti Parab, Danda Nata or any such festivals which may effect the work schedule. Therefore, the contractor should engage more work forces during working period available at his disposal to complete the work as per schedule.
- (b) In the peak summer season, working hour is curtailed by the Labour Department to avoid exposure to personnel to the scorching sun and heat. It is the duty of the agency to increase the number of work force and to employ the existing work force during morning and afternoon hours as per Government orders.
- (c) Rainfall is a normal occurrence during monsoon in Odisha. So, unless there is unusually heavy rainfall resulting in a declared calamity, the contractor is not eligible for any extension of time. The contractor should plan the deployment of workforce and machinery , so as to complete the work as per schedule considering ordinary vagaries of nature.

The same applies for borrow area ponding also. The contractor should foresee possible ponding of borrow area in monsoon and like wise lift more quantity of soil/ other materials during dry period, so as to complete the work as per schedule.

- (d) The contractor should take up the work with due diligence in the acquired land without waiting for acquisition of entire land. This should be completed in proportionally less period depending on the quantum of available work front.
- (e) The Agency should plan his work programme and mobilize men and machineries considering the canal closure programme of a particular system or area. Khariff / Rabi closure can't be imposed arbitrarily on the farmers as per the convenience of the agency. Closure of canal for the interest of work will be solely at the discretion of the Engineer-in- charge and can't be claimed as a matter of right.
- (f) There will be always be standing crop before harvesting season as per crop schedule and this fact has to be clearly understood by the agency. Extension of time on this ground may not be considered by the Division officer.

- (g) Only the day(s) of elections to the Local Bodies / Assembly / Parliament will be treated as non working day(s)

#### **84. Definitions**

In the contract (as hereinafter defined) the following words and expressions will have the meanings here by assigned to them.

- a) Approved / Approval – Means approved in writing.
- b) Construction Plant – Means all equipments, appliances or things of whatsoever nature required for the execution, or completion, maintenance of the works or temporary works but does not include materials or other things intended to form or forming part of the permanent work.
- c) Contract – means the instruction and information for tenderers General and Special conditions of the contract, Technical Specification, drawings, tender (including the schedule of quantities and tender prices) the formal agreement and all agenda and attachment related to the above.
- d) Contractor – means the particular person, firm or corporation with whom the contract has been made for executing the work.
- e) Drawing – Means the drawings referred to in the specifications, any modifications of such drawings approved in writing by the **Superintending Engineer, Angul Irrigation Division, Angul** and such other drawings as may from time to time be furnished or approved in writing by the Engineer-in-Charge.
- f) Engineer-in-Charge–Means the Superintending Engineer, in-charge of the work specified or parts of the works under the contract, or such other departmental assistants or sub-ordinates to whom the Superintending Engineer, in-charge may have delegated certain duties, acting separately within the scope of particular duties entrusted to them.
- g) Government – Means Government of Odisha, Department of Water Resources.
- h) I.S.S. / B.I.S. – Means Indian Standard Specifications / Bureau of Indian Standard.
- i) Temporary Works – Means all temporary works of every kind required for the performance of the contract.
- j) Specification – Whenever the terms “Specification” is used, apart from a specified standard specification, it shall mean the specification or plan prepared for a particular site as instructed to the contractor in executing that item of work.
- k) Year - Means Financial Year.

**85. THE CONTRACTOR HAS TO MENTION PERCENTAGE EXCESS OR LESS OVER THE AMOUNT PUT TO TENDER.**

**86. The contractor will write percentage excess or less upto two decimal point only if he writes the percentage excess or less upto more than two decimal point, the two decimal point shall only be considered without rounding up.**

**87. A bidder can submit only one tender paper for a particular work, submission of more than one tender paper by a bidder for a particular tender will liable for rejection of all such tender papers as per Works Department Letter No.4985/W dt.28.03.2007.**

**88. The single tender received in the first call shall be cancelled without opening of the bid. The acceptance of a single tender received, even after retendering should have prior approval of the next higher authority as per**

Works Department Memorandum No.16 dt.01.01.2015.

- 89.** Security for the due fulfillment of a contract should invariably be taken. The security may be taken in shape of N.S.C/Post Office Savings Bank Account/Post Office Time Deposit Account/Kisan Vikas Patra/Bank Guarantee in favour of the Divisional Officer from any Nationalized Schedule Bank in India counter guaranteed by its local Branch at Bhubaneswar/e-Bank Guarantee executed on the National-Governance Services Limited (NeSL) Digital Document Execution Portal towards E.M.D/Initial Security Deposit/any other security deposit from the contractor or supplier.

# **SECTION-2**

## **INFORMATION AND INSTRUCTION TO TENDERERS**

## **SECTION-2**

### **1. Preparation of Tender Documents**

The intending tenderer shall log in to the e-procurement portal identified as <http://tendersodisha.gov.in> and download the technical bid (Cover-I) and price bid (Cover-II) in shape of a bill of quantity in MS Excel format. As per the requirement of the bid document the bidder will fill up the required informations and fill up the percentage in figures on the bill of quantity in MS Excel sheet. The bidder is to scan his registration certificate, GSTIN, PAN Card, Affidavit, No relation certificate and certificate issued by competent authorities required for fulfilling the eligibility criteria specified in the bid document for the work. The bidder is also required to scan the other documents as specified in the bid document.

### **2. Method of submission of Tender Documents**

The tenderer shall upload the scanned copy / copies of the documents and information as per requirement of the bid documents through the e-procurement portal. All documents and scanned copies are to be uploaded in the designated location of the technical bid (Cover-I) except the filled up bill of quantity in excel sheet. The filled up intelligent bill of quantities in Excel format will be uploaded in the designated location of price bid (Cover-II). The bidder is required to upload the required documents in appropriate location of Technical and Financial bid failing which the bid will be rejected. All the uploaded documents should be clear and legible. Before activating the submit button the clarity of the document may be ensured by taking out a sample copy. In the e-procurement tendering system the bidder is required only to submit the required information as per bid document instead of submitting the entire technical bid document. The “online” bidder shall digitally sign on all statements, documents, clarifications uploaded by him owning responsibility for their corrections/ authenticity. **If any of the information furnished by the bidder is found to be false/ fabricated/ bogus, the bidder will be blacklisted.**

**2.1.** The tender documents duly filled in and signed by the intending tenderer should be submitted in on-line through prescribed website only.

**2.2** If the intending tenderer is an individual, the documents shall be signed by the individual above his full type written name and current address.

**2.3** If the intending tender is a proprietary firm it shall be signed by the proprietor above his full name and with his current address.

2.4 If the intending tenderer is a firm in partnership it shall be signed by a partner holding the power of attorney for the firm in partnership in which case a certified copy of power of attorney shall accompany in the pre-qualification documents.

2.5 If the intending tenderer is a limited company or Corporation, it shall be signed by a duly authorized person holding the power of attorney in which case certified copy of power of attorney shall accompany.

2.6 All witness and sureties shall be of person of status and probity and their full names, occupation and address shall be stated below their signatures.

2.7 The agency will install display board mentioning information about the work at work site after drawl of the agreement at his own cost.

### **3. Opening of Tender Documents.**

The tender documents (Technical Bid) will be **opened on 08.07.2026 at 11.30A.M** in the office of the **Additional Chief Engineer, Angul Irrigation Circle, Angul** in the presence of tenderers or their authorized representative, who wish to be present.

### **4. DELETED.**

### **5. Final Decision making authority**

The competent authority reserves the right to accept or reject or disqualify any of the tender of prequalification without assigning any reasons and its decision shall be final.

### **6. Further Clarification**

The **Superintending Engineer, Angul Irrigation Division, Angul / Additional Chief Engineer, Angul Irrigation Circle, Angul** may be contacted during office hours on any working days for any further clarification. Online clarification may also be obtained as per the date line mentioned in the NIT.

### **7. Sample of all material:**

The Contractor shall supply sample of all materials fully before procurement for the work for testing and acceptance at his own cost as may be requiring by the concerned Superintending Engineer.

8. **Trial Boring** : The foundation level as indicated in the body of the departmental drawing is purely tentative and for the general guidance only. The Department have no responsibility for the suitability of actual strata at the foundation level. The contractor has to conduct his own boring before starting the work and get the samples tested at his own cost to ascertain the S.B.C. and credibility of the strata at founding level. While quoting his rates for tender the contractor shall take in to account of the above aspects.

9. From the commencement of the works to the completion of the same, they are to be under the contractor's charge. The contractor is to be held responsible to make good all injuries, damages and repairs occasioned or rendered necessary to the same by fire or other causes and they hold the Govt. of Odisha harmless for any claims for injuries to person or structural damage to property happening from any neglect, default, want of proper care or misconduct on the part of the contractor or any one in his employment during the execution of the work. Also, no claim shall be entertained for loss due to earthquake, flood, cyclone, epidemic, riot or any other calamity whether natural or incidental damages so caused will have to be made good by the contractor at his own cost.

10. Where it will be found necessary by the Department, the Officer-in-Charge of the work shall issue a site order book to the contractor to be kept at the site of the work with pages serially numbered. Orders regarding the work whenever necessary are to be entered in his book by the PWD Officer-in-Charge with their dated signatures and duly noted by the contractor or his authorized agents with their dated signature. Orders entered in his book and noted by the contractor's agent shall be considered to have been duly given to the contractor for following the instructions of the Department. The site order book shall be the property of the Department and shall not be removed from the site of work without written permission of the Engineer (Superintending Engineer) and to be submitted to the Engineer-in-Charge every month.

11. The tenderer should conduct three bores at each pier and SBC of soil at foundation level and abutments location and furnish the test results in conformity with IRC code at his own cost before execution of the work and rates quoted by the contractor should be inclusive of such bores and SBC tests etc without any extra cost to the Department.

## Procedure to participate in online bidding e-procurement

1. PARTICIPATING IN THE BID IN THE E-PROCUREMENT PORTAL: The Contractor/ Bidder intending to participate in the bid is required to register in the Portal using his /her active personal/ official e-mail ID as his Login ID and attach his/her valid Digital Signature Certificate (DSC) to his/her unique Login ID. The DSC used must be of appropriate class (Class II or Class III) issued from a registered Certifying Authority such as n-Code , Sify, TCS, MTNL etc. He/She has to submit the relevant information as asked for about the firm/ contractor. The portal registration of the bidder/ firm is to be authenticated by the State Procurement Cell after verification of original valid certificates/ documents such as (i) PAN and (II) Registration Certificate (RC)/ GST Registration Certificate and GSTIN (for procurement of goods) of the concerned bidder. The time period of validity in the portal is at par with validity of RC/GST Registration Certificate and GSTIN. Any change of information by the bidder is to be re-authenticated by the State Procurement Cell. After successful authentication bidder can participate in the online bidding process.

Contractor not registered with Government of Odisha, can participate in the e-procurement after necessary enrollment in the portal but have to subsequently register themselves with the appropriate registering authority of the State Government before award of the work as per prevalent registration norms of the State.

- a. To log on to the portal the Contractor/Bidder is required to type his/her *user name* and password. *The system will again ask to select the DSC and confirm it with the password of DSC.* For each login, a user's DSC will be validated against its date of validity and also against the Certificate Revocation List (CRL) of respective CAs stored in system database. The system checks the unique ID, password and DSC combination and authenticates the login process for use of portal.
- b. The bidder can download the tender of his choice and save it in his system and undertake the necessary preparatory work off-line and upload the completed tender at his convenience before the closing date and time of submission.
- c. The tender documents uploaded by the Tender Inviting Officer in the website <https://tendersodisha.gov.in> will appear in the section of "Upcoming Tender" before the due date of tender sale. Once the due date has arrived, the tender will move to "Active Tender" Section of the *home page*. Only a small notification will be published in the newspaper specifying the work details along with *mention* of the specific website for details. The publication of the tender will be for specific period of time till the last date of submission of bids as mentioned in the 'Invitation for Bid' after which the same will be removed from the list of Active tenders. Any bidder can view or download the bid documents from the website.

- d. Contractor exempted from payment of EMD will be able to participate in the tender directly by uploading documentary evidences towards his eligibility for such exemption.
  - e. The *software* application has the provision of payment of cost of tender document through payment gateways of *authorized* bankers by directly debiting the account of the bidders.
- Bidders participating through Joint Venture shall declare the authorized signatory through Memorandum of Understanding duly registered and enroll in the portal in the name and style of the joint venture company. It is mandatory that the DSC issued in the name of the authorized signatory is used in the portal.
  - In the case of any failure, malfunction, or breakdown of the electronic system used during the e-procurement process, the tender inviting officer shall not accept any responsibility for failures or break downs other than in those systems strictly within their own control.
  - Any third party/company/person under a service contract for operation of e-procurement system in the State or his/their subsidiaries or their parent companies shall be ineligible to participate in the procurement processes that are undertaken through the e-procurement system irrespective of who operates the system.
  - For submission of Bids through the E-Procurement Portal, the bidder shall upload the scanned copy/copies of document in prescribed format wherever warranted in support of eligibility criteria and qualification information. The online bidder shall have to produce the original documents in support of the scanned copies and statements uploaded in the portal before the specified date as per DTCN.
  - Each bidder shall submit only one bid for one package. A bid is said to be complete if accompanied by cost of bid document and appropriate bid security. The system shall consider only the last bid submitted through the E-Procurement portal.
  - The bidder may ask question related to tender online in the e-procurement portal using his/her DSC, provided the questions are raised within the period of seeking clarification as mentioned in tender call notice/Bid. The Officer inviting the Bid/ Procurement Officer-Publisher will clarify queries related to the tender.
  - The details of drawings and documents pertaining to the works available with the officer inviting the Bid as well as in the office of the Superintending Engineer as mentioned in the Contract Data will be open for inspection by the bidders. The bidder is required to download all the documents for preparation of his bid. It is not necessary for the part of the Bidder to up-load other Bid documents (after signing) while up-loading his bid. He is required to up load documents related to his eligibility criteria and qualification information and Bill of Quantities duly filled in. It is assumed that while participating in the bid, the bidder has referred all the drawings and documents. Seeking any revision of rates or backing out of the bid claiming for not having referred to any or all documents provided in the Bid by the Officer Inviting the Bid will be construed as plea to disrupt the bidding process and in such cases the bid security shall be forfeited.
  - Any addendum / corrigendum/ cancellation of tender shall be published in the website <https://tendersodisha.gov.in>, notice board Only, and such notice shall form part of the bidding documents.

The system generates a mail to those bidders who have already uploaded their tenders and those bidders if they wish can modify their tenders. The bidders are required to check the website till last date and time of bid submission for any addendum/ corrigendum/ cancellation thereof. Tender inviting authority is not responsible for communication failure of system generated mail.

All the volumes/documents shall be uploaded / provided in the portal by the Officer inviting the bid. The bidder shall carefully go through the document and prepare the required documents and upload the scanned documents in Portable Document Format to the portal in the designated locations of Technical Bid. He will fill up the rates of items or percentage in the BOQ downloaded for the work in designated Cell and up loads the same in designated locations of Financial Bid. Bidders are to submit only the original BoQ uploaded by publisher after entering the relevant fields without any alteration/deletion/modification. Multiple BoQ submission shall lead to cancellation of bid. In case of item rate tender, bidders shall fill in their rates other than Zero value in the specified cells. In the percentage rate tender, the bidder quoting Zero value is valid and will be taken as Schedule of Rates. Submission of document shall be affected by using DSC of appropriate class.

2. PAYMENT OF EMD/ BID SECURITY AND COST OF BID DOCUMENTS: The Bidder shall furnish, as part of his Bid, a Bid security for the amount mentioned under DTCN in online mode. Non-submission of bid security within the designated period shall debar the bidder from participating in the on-line bidding system.

The EMD or Bid Security payable along with the bid is 1% of the estimated contract value (ECV) or as mentioned in the bid document.

The tender accepting authority will verify the originals of all the scanned documents of the successful lowest bidder only within 5 days of opening of the tender (price bid). In the eventuality of failure on the part of the lowest successful bidder to procedure the original documents, he will be debarred in future from participating in tender for 3 years and will be black listed by the competent authority. In such as situation, successful L-2 bidder will be required to produce his original documents for consideration of his tender at the negotiated rate equal to L-1 bidder.

Contractor exempted from payment of EMD will be able to participate in the tender directly by uploading documentary evidences towards his eligibility for such exemption.

Government of Odisha has introduced e-payment gateway in to the portal for payment of cost of Bid and Bid Security/ Earnest Money Deposit. The process of using e-payment gateway is mentioned in the “**Procedure for Electronic receipt, accounting and reporting of Cost of Tender Paper and Earnest Money Deposit on submission of bids**”.

FORMAT AND SIGNING OF BID: (Logging to the Portal)-The Contractor/ Bidder is required to type his/her Login ID and Password. The system will again ask to select the DSC and

confirm it with the password of DSC as a second stage authentication. For each login, a user's DSC will be validated against its date of validity and also against the Certificate Revocation List (CRL) of respective CAs stored in system database. The system checks the unique Login ID, Password and DSC combination and authenticates the login process for use of portal.

- 3.1 The bidder can download the tender of his choice and save it in his system and undertake the necessary preparatory work off-line and upload the completed tender at his convenience within the final date and time of submission. The bidder shall only submit single copy of the required documents and Price Bid in the portal. In the Financial bid, the bidder can not leave any figure blank. He has to only write the figures; the words will be self generated. The Bidders are advised to upload the completed Bid document well ahead of the last date & time of receipt to avoid any last moment problem of power failures etc.
- 3.2 The Bidder shall go through the Bid carefully and list the documents those are asked for submission. He shall prepare all documents including Declaration form, price bid etc and store in the system.
- 3.3 The bidder shall log on to the portal with his DSC and move to the desired tender for uploading the documents in appropriate place one by one simultaneously checking the documents. Once the Bidder makes sure that all the documents have been up-loaded in appropriate place he clicks the submit button to submit the bid to the portal.
- 3.4 The bids once submitted can not be retrieved or corrected. Tender cannot be pre-opened and cannot be submitted after due date and time. Therefore only after satisfying that all the documents have been uploaded, the Bidder should activate submit button.
- 3.5 In the e-procurement process each processes are time stamped. The system can identify each individual who has entered in to the portal for any bid and the time of entering into the portal.
- 3.6 The Bidder should ensure clarity of the document uploaded by him to the portal especially the scanned documents by taking out sample printing. Non-submission of legible documents may render the bid non-responsive. However, the Officer inviting the Bid if so desires can ask for legible copies or original copies for verification within a stipulated period provided such document in no way alters the Bidder's price bid. If the Bidder fails to submit the original documents within the stipulated date, his bid security shall be forfeited.

### 3.7 SUBMISSION OF BIDS:-

The bidder shall carefully go through the tender and prepare the required documents. The bid shall have a Technical Bid and a Financial Bid. The Technical bid generally consists of GSTIN, PAN, Registration Certificate, Affidavits and any other information required by OIT. The Financial Bid shall consist of the Bill of Quantities (BOQ) and any other price related information/undertaking including rebates.

Bidders are to submit only the original BOQ ( in .xls format) uploaded by Procurement Officer Publisher (Officer Inviting Tender) after entering the relevant fields without any alteration/ deletion/ modification. Multiple BOQ submission by bidder shall lead

to cancellation of bid. In case of items rate tender , bidders shall fill in their rates other than zero value in the specified cells without keeping it blank. In the percentage rate tender the bidder quoting zero percentage is valid and will be taken at par with the estimated rate of the work put to tender.

The bidder shall upload the scanned copy/ copies of document in support of eligibility criteria and qualification information in prescribed format in Portable Document Format (PDF) to the portal in the designated locations of Technical Bid.

- a. The bidder shall write his name in the space provided in the specified location in the Protected Bill of Quantities (BOQ) published by the Officer Inviting Tender. The bidder shall type rates in figure only in the rate column of respective items(s) without any blank cell in the rate column in case of item rate tender and type percentage excess or less upto two decimal place only in case of percentage rate tender.
- b. The bidder shall log on to the portal with his/ her DSC and move to the desired tender for uploading the documents in appropriate place one by one simultaneously checking the documents.
- c. Bids cannot be submitted after due date and time. The bids once submitted can not be viewed, retrieved or corrected. The Bidder should ensure correctness of the Bid prior to uploading and take print out of the system generated summary of submission to confirm successful uploading of bid. The bids cannot be opened even by the OIT or the Procurement Officer Publisher/opener before the due date and time of opening.
- d. Each process in the e-procurement is time stamped and the system can defect the time of login of each user including the Bidder.
- e. The Bidder should ensure clarity/legibility of the document uploaded by him to the portal.
- f. The system shall require all the mandatory forms and fields filled up by the contractor during the process of submission of the bid/tender.
- g. The bidder should check the system generated confirmation statement on the status of the submission.
- h. The bidder should upload sufficiently ahead of the bid closure time to avoid traffic rush and failure in the network.
- i. The Tender Inviting Officer is not responsible for any failure, malfunction or breakdown of the electronic system used during the e-procurement process.
- j. The Bidder is required to upload documents related to his eligibility criteria and qualification information and Bill of Quantity duly filled in. It is not necessary for the part of the bidder to upload the drawing and the other Bid documents (after signing) while uploading his bid. It is assumed that the bidder has referred all the drawings and documents uploaded by the Officer Inviting the Bid.
- k. The Bidder will not be able to submit his bid after expiry of the date and time of submission of bid (server time). The date and time of bid submission shall remain unaltered even if the specified date for the submission of bids declared as a holiday for the Officer Inviting the Bid.

l. Seeking any revision of rates for backing out of the bid claiming for not having referred to any or all documents provided in the bid by the officer inviting the bid will be construed as plea to disrupt the bidding process and in such cases the bid security shall be forfeited.

m. The 'Online bidder' shall digitally sign on all statements documents, certificates uploaded by him, owning responsibility for their correctness/ authenticity as per IT ACT 2000. If any of the information furnished by the bidder is found to be false/ fabricated/ bogus, his EMD/BID Security shall stand forfeited and his registration in the portal shall be blocked and the bidder is liable to be blacklisted.

#### **4 SECURITY OF BID SUBMISSION:**

All bid data uploaded by the Bidder to the portal will be encrypted by the DSC of the opener(s). The system shall require all the mandatory forms and fields filled up by the contractor during the process of submission of the bid/tender.

The Bid shall be received in encrypted format by the system which can only be decrypted /opened by the authorized openers only on or after the due date and time.

#### **5 DEADLINE FOR SUBMISSION OF THE BIDS:**

The online bidding will remain active till the last date and time of the bid submission. Once the date and time (Server date and time) is over, the bidder will not be able to submit the bid. The date & time of bid submission shall remain unaltered even if the specified date for the submission of bids declared as a holiday for the Officer inviting the Bid.

#### **RESUBMISSION AND WITHDRAWAL OF BIDS:**

Resubmission of bid by the Bidders for any number of times before the final date and time of submission is allowed.

Resubmission of bid shall require uploading of all documents including price bid afresh.

If the bidder fails to submit his modified bids within the pre-defined time of receipt, the system shall consider only the last bid submitted.

The bidder should avoid submission of bid at the last moment to avoid system failure or malfunction of Internet of traffic jam of power failure etc.

The Bidder can withdraw his bid before the closure date and time of receipt of the bid by uploading scanned copy of a letter addressing to the Procurement Officer Publisher (Officer Inviting Tender) citing reasons for withdrawal. The system shall not allow any withdrawal after expiry of the closure time of the bid.

#### **6 LATE BIDS:**

6.1. The system shall reject submission of any bid through portal after closure of the receipt time. For all purpose the server time displayed in the e-procurement portal shall be the time to be followed by the bidder and concerned officers.

## **7 MODIFICATION AND WITH DRAWAL OF BIDS:**

In the E-Procurement Portal, it is allowed to modify the bid any number of times before the final date and time of submission. The bidder shall have to log on to the system and resubmit the documents as asked for by the system including the price bid. In doing so, the bids already submitted by the bidder will be removed automatically from the system and the latest bid only will be admitted. But the bidder should avoid modification of bid at the last moment to avoid system failure or malfunction of internet or traffic jam or power failure. If the bidder fails to submit his modified bids within the designated time of receipt, the bid already in the system shall be taken for evaluation.

In the E-Procurement Portal, withdrawal of bid is allowed. But in such case he has to write a letter with appropriate reasons for his withdrawal addressed to the Officer inviting the bid and upload the scanned document to portal in the respective bid before the closure date and time of receipt of the bid. The system shall not allow any withdrawal after expiry of the closure time of the bid.

## **8. OPENING OF THE BID:**

8.1. Bid opening date is specified during tender creation or can be extended with corrigendum. This date is available in IFB, tender document as well as the home page of portal. Bid opening can be done by the authorized users which are defined during the tender publication / approval stage. The bids are encrypted using their public keys and can be decrypted only on or after the Bid Opening due date and time. The bid openers private key will be required to open the bids and all the openers have to log on to the portal during that time.

8.1.1. The bidders who participated in the online bidding can witness opening of the bid from any system logging on to the portal with the DSC away from opening place. Contractors are not required to be present during the bid opening at the opening location if they so desire.

8.1.2. Each activity is date and time stamped with user details. For time stamping, server time is taken as the reference.

8.2. In the event of the specified date of bid opening being declared a holiday for the Officer inviting the Bid/Engineer-in-Charge, the bids will be opened at the appointed time on the next working day.

8.2(a) Combined bid security for more than one work is not acceptable.

8.3. In case bids are invited for more than one package, the order for opening of the "Bid" shall be that in which they appear in the "Invitation for Bid".

8.4. The Bid openers; who have been pre-defined shall log on to the portal with their respective DSC. Unless all the Officers who have been declared as Opening officers, log on the portal with their DSC the Tender cannot be opened.

8.5. In case of non-responsive tender the officer Inviting tender should complete the e-Procurement process by uploading the official letter for cancellation/ re-tender.

### **EVALUATION OF BIDS:-**

All the opened bids shall be downloaded and printed for taking up evaluation. The officer authorized to open the tender shall sign and number on each page of the documents downloaded and furnish a certificate that "the documents as available in the portal containing..... nos. of pages".

- 8.5.1. After opening of technical bid, the bidder may be asked in writing / online (in their registered e-mail ID) to clarify on the uploaded documents provided in the Technical Bid, if necessary, with respect to any doubts or illegible documents required for Technical Evaluation. The Officer Inviting Tender may ask for any other document of historical nature during Technical Evaluation of the tender. Provided in all such cases, furnishing of any document in no way alters the bidders price bid. Non submission of legible documents may render the bid non-responsive. The authority inviting bid may reserve the right to accept any additional document.
- 8.5.2. The bidders will respond in not more than 7 days of issue of the clarification letter, failing which the bid of the bidder will be evaluated on its own merit.
- 8.5.3 The Technical evaluation of all the bids shall be carried out as per information furnished by Bidders.
- 8.5.4. Immediately, on receipt of these clarifications, the Evaluating Officers; predefined in the system for the bid, will finalize the list of responsive bidders. They will log on to the site with their DSC and record their comments on the Technical evaluation page in the system. The Officer Inviting the Bid if also the accepting authority, shall log on to the system with his digital signature and check the technical evaluation. He can either accept or pass on to the evaluating officers for re-evaluation. Upon acceptance of technical evaluation by the Accepting authority in the system, the system shall automatically generate letter to all the responsive bidders and the system shall forward the letter to all the responsive bidder that their technical bid has been evaluated responsive with respect to the data/information furnished by him and the letter shall also intimate him the date & time of opening of financial bid. The system shall also inform the non-responsive bidders in their e-mail ID that their bid has been found non-responsive.
- 8.6. The Technical evaluation of all the bids shall be carried out up as per the information furnished by the Bidders. But evaluation of the bid does not exonerate the bidders from checking their original documents and if at a later date the bidder is found to have misled the evaluation through wrong information, action as per relevant clause of DTCN shall be taken against the bidder/contractor.
- 8.7 The Procurement officer-Evaluators will evaluate bid and finalized list of responsive bidders. Opening of price bid and evaluation of lowest bidder is subject to satisfaction of other qualification information.
- 8.7.1 The financial bids of the technically responsive bidders shall be opened on the due date of opening. The Procurement Officer-Openers shall log on to the system in sequence and open the financial bids.
- 8.7.2 The Financial Bid will be opened on the notified date & time in the presence of bidders or their authorised representative who wish to be present.
- 8.7.3 At the time of opening of “Financial Bid”, the names of the bidders whose technical bids were found responsive will be announced and the bids of only those bidders will be opened. The remaining bids will be rejected.
- 8.7.4 The responsive bidders’ name, the bid prices, the item wise rates, the total amount of each item in case the item rate tender and percentage above or less in case of percentage rate tenders will be announced. any discounts and withdrawals, and such other details as the officer inviting the tender may consider appropriate, will be announced by him or his authorized representatives at the time of opening.
- 8.7.5 The Financial bid of the bidders shall be opened one by one by the designated officers. The system shall auto-generate the Comparative statement.

- 8.7.6 The Bidder can witness the principal activities and view the documents/summary reports for that particular work by logging on to the portal with his DSC from anywhere.
- 8.7.7 Procurement Officer-Openers shall sign on each page of the download BOQ and the Comparative Statement and furnish a certificate to that respect.
- 8.7.8 System provides an option to Procurement Officer Publisher for reconsidering the rejected bid with the approval of concern Chief Engineer/ Head of Department.

**9. CLARIFICATION AND NEGOTIATION OF BIDS:**

- 9.1. For examination, evaluation, and comparison of bids, the officer inviting the bid may, at his discretion, ask the lowest bidder for clarification of his rates including reduction of rate on negotiation and breakdowns of unit rates.
- 9.2. On opening of the price bid the system shall arrange the financial bids in order of their value (L1 first, followed by L2, L3 ....) for subsequent evaluation. The evaluation status (Sheet) will be visible to all the participating bidders after opening on their respective logins. Each activity is recorded in the system with date and time stamping.

**10. NOTIFICATION OF AWARD AND SIGNING OF AGREEMENT:**

- 10.1. In the E-Procurement Portal, the system shall generate the template of award letter and the Officer Inviting the Bid shall mention the amount of Performance Security and additional security required to be furnished in the letter and intimate the bidders in his e-mail ID.
- 10.2. The Employer/ Engineer-in-Charge shall notify acceptance of the work prior to expiry of the validity period by cable, telex or facsimile or e-mail confirmed by registered letter. This letter of Acceptance will state the sum that the Engineer-in-Charge will pay the contractor in consideration of execution and completion of the works by the contractor as prescribed by the contract and the amount of performance security and Additional Performance Security required to be furnished. The issue of the letter of Acceptance shall be treated as closure of the Bid process and commencement of the contract.
- 10.3. The Contractor after furnishing the required acceptable Performance Security and Additional Performance Security, “ Letter of Proceed” or “Work Order” shall be issued by the Engineer-in-Charge with copy thereof to the Procurement Officer-Publisher. The Procurement Officer-Publisher shall up load the summery and declare the process as complete.
- 10.4. If the L1 bidder does not turn up for agreement after finalisation of the tender then he shall be debarred from participation in bidding for three years and action will be taken to blacklist the contractor. Besides the consortium/ JV/firm where such an agency/ firm already happens to be or is going to be a partner/ member/ proprietor, he/ they shall neither be allowed for participation in bidding for three years nor his/ their application will be considered for registration and action will be initiated to blacklist him/ them. In that case, the L2 bidder, if fulfils other required criteria would be called for drawing agreement for execution of work subject to condition that the L2 bidder negotiates at par with the quoted by the L1 bidder, otherwise the tender will be cancelled.

**11. BLOCKING OF PORTAL REGISTRATION**

- 11.1 If the registration Certificate of the contractor is cancelled/ suspended by the registering authority/ blacklisted by the competent authority his portal registration shall be blocked automatically on receipt of information to that effect.
- 11.2 The portal registration blocked in the ground mentioned in the above Para- 11.1 shall be unblocked automatically in receipt of revocation order of cancellation/ suspension/ blacklisting from the concerned authority.

- 11.3 The Officer Inviting Tender shall make due inquiry and issue show cause notice to the concerned contractor who in turn shall furnish his reply, if any, within a fortnight from the date of issue of show cause notice. Thereafter the Officer Inviting Tender is required to issue an intimation to the defaulting bidder about his unsatisfactory reply and recommend to the Chief Manager (Tech) for blocking of portal registration within 10 days of intimation to the defaulting bidder regarding his unsatisfactory reply with intimation to the Registering Authority and concerned Chief Engineer/ Heads of Office if any of the following provisions are violated.
- 11.3.1 Fails to furnish original Technical Documents before the designated officer within the stipulated date and time.
- 11.3.2 Backs out from the bid on any day after the last date of receipt of tender till expiry of the bid validity period (including till the extended bid validity period)
- 11.3.3 Fails to execute the agreement within the stipulated date.
- 11.3.4 If any of the information furnished by the bidder is found to be false/ fabricated/ bogus. Accordingly the officer Inviting Tender shall recommended to the Chief Manager (Tech) State Procurement Cell, Odisha for blocking of portal registration of bidder and simultaneously action shall also be initiated by OFFICER INVITING TENDER for blacklisting as per Appendix-XXXIV of OPWD code Volume-II.

The minimum period of blocking of Portal Registration shall in no case be less than 180 days.

## **SECTION – 3**

### **Government Guidelines**

**GOVERNMENT GUIDELINES**

**Appendix - I**

**Executive Instruction regarding calling for and acceptance of tenders in e-Procurement in Govt. of Odisha.**

**Government of Odisha  
Works Department**

\*\*\*

**Office Memorandum**

**File No.07556900042013 (Pt-II) – 7885/W Dated 23.07.2013**

**Sub: Codal Provision regarding e-Procurement**

After introduction of e-procurement in Government of Odisha, necessary guidelines / procedures has been issued in Works Department Office Memorandum No.1027 dt.24.01.2009 which consists of the procedural requirement for e-procurement of tenders. After careful consideration Government have been pleased to make following modifications to codal provisions by way of addition as Appendix – IX(A) of OPWD Code Vol.II) as follows:

**(Appendix-IX (A) of OPWD Code, Vol-II)**

**Executive instructions regarding calling for and acceptance of tenders in e-Procurement.**

1. This office memorandum consists of the procedural requirement of e-procurement and shall be made part of the Detailed Tender Call Notice or Instruction to Bidder for all “works” tenders hoisted in the portal.
2. The e-procurement portal of Government of Odisha is “<https://tendersodisha.gov.in>”.
3. Use of valid Digital Signature Certificate of appropriate class (Class II or class III) issued from registered certifying authorities (CA) as stipulated by Controller of Certifying Authorities (CCA), Government of India such as n-Code, Sify, TCS, MTNL, e-Mudhra is mandatory for all users.
4. The DSC issued to the Department users is valid for the period of two years only. All the Department users are responsible to revalidate their DSC prior to expiry.
5. For all purpose, the server time displayed in the e-Procurement portal shall be the time to be followed by all the users.
6. Government after careful consideration have decided to hoist all tenders costing 10 lakhs or above in the e-procurement portal. This will be applicable across all Engineering Departments such as Works Department, Department of Water Resources, Rural Development and DEPARTMENT OF WATER RESOURCES. Government of Odisha also welcomes hoisting of tenders by any other departments, authority, corporations, local bodies etc. of the State with prior approval from Works Department. Works Department is the Nodal Department for the implementation of e-Procurement in the State.
7. The e-procurement shall be operated compliant to relevant provisions of OGFR/ OPWD code/ Accounts code/ Government statues including any amendments brought from time to time to suit to the requirement of the best national practice.
8. Registration in the e-procurement portal is without levy of any charges but Government reserves the right to levy any charges for such value added services in future.
9. Contractor not registered with Government of Odisha, can participate in the e-Procurement after necessary enrolment in the portal but have to subsequently register themselves with the appropriate registering authority of the State Government before award of the work as per prevalent registration norms of the State.

10. For the role management “Department” is the Administrative Department, Organisation or wing is the Chief Engineer or highest tender accepting authority or equivalent officer, Division is the Superintending Engineer or equivalent Officer and Subdivision is the Assistant Engineer or equivalent officer.
11. The e-Procurement software assigns roles for operation of the module for specific function. The terminologies used in the portal and their respective functions in the software are as follows.
  - a. Application Administrator (NIC & State Procurement Cell)
    - i. Master Management
    - ii. Nodal Officer Creation
    - iii. Report Generation
    - iv. Transfer of Officer’s login ID.
    - v. Blocking & unblocking of officer’s and bidder’s login ID.
  - b. Nodal Officer (At organization level not below the Superintending Engineer or equivalent rank)
    - i. Creation of Users
    - ii. Role Assignment
    - iii. Report Generation
    - iv. Transfer of Officer’s login ID.
    - v. Blocking & unblocking of officer’s Login ID.
  - c. Procurement Officer Publisher (Officer having tender inviting power at any level)
    - i. Publishing of Tender
    - ii. Publishing of Corrigendum / addendum / cancellation of Tender
    - iii. Bid Clarification
    - iv. Uploading of Pre-Bid minutes.
    - v. Report generation.
  - d. Procurement Officer Administrator (Generally sub-ordinate officer to Officer Inviting Tender)
    - i. Creation of Tender
    - ii. Creation of Corrigendum / addendum / cancellation of Tender
    - iii. Report generation.
  - e. Procurement Officer Opener (Generally sub-ordinate officer to Officer Inviting Tender)
    - ii. Opening of Bid
  - a. Procurement Officer Evaluator (Generally Sub-Ordinate Officer to Officer Inviting Tender)
    - i. Evaluating Bid
  - b. Procurement Officer-Auditor (Procurement Officer Publisher and/or Accounts Officer / Finance Officer)
    - i. To take up auditing

12. **NOTICE INVITING BID (NIB) or INVITATION FOR BID (IFB):**

- a. The Notice Inviting Bids (NIB) and Bid documents etc., shall be in the Standard formats as applicable to conventional Bids and will be finalized / approved by the officers competent as in the case of conventional Bids.
- b. The officers competent to publish NIB in case of conventional Bids will host the NIB in portal. Simultaneously, a notification should also be published in the newspapers, as per existing rules preferably, in the following format, to effect economy:-

Government of Odisha “e”procurementNotice	
<b>Bid Identification No.</b> -----	
1.	Nameofthework: .....
2.	Estimatedcost: Rs.....
3.	Period of completion -----
4.	Date&Time of availability of bid document in the portal _____
5.	Last Date / Time for receipt of bids in the portal _____
6.	Name and address of the O.I.T.:.....
Further details can be seen from the e-procurement portal “ <a href="https://tendersodisha.gov.in">https://tendersodisha.gov.in</a> ”	

- c. The tender documents published by the Tender Inviting Officer (Procurement Officer Publisher) in the website <https://tendersodisha.gov.in> will appear in the “Latest Active Tender”. The Bidders/ Guest Users can download the Bid documents only after the due date & time of sale. The publication of the tender will be for specific period of time till the last date of submission of bids as mentioned in the ‘Notice inviting Bid’ after which the same will be removed from the list of “Latest Active tenders”.

13. **ISSUE OF ADDENDA/ CORRIGENDA/ CANCELLATION NOTICE:**

- a. The Procurement Officer Publisher (Officer Inviting Tender) shall publish any addendum/ corrigendum/ cancellation of tender in the website <https://tendersodisha.gov.in>, notice board and through paper publication and such notice shall form part of the bidding documents.
- b. The system generates a mail to those bidders who have already uploaded their tenders and those bidders if they wish can modify their tenders. The bidders are required to watch the website till last date and time of bid submission for any addendum/ corrigendum/ cancellation thereof. Tender Inviting Authority is not responsible for communication failure of system generated mail.

14. **CREATION AND PUBLISHING OF BID:**

- a. All the volumes/documents shall be uploaded in the portal by the tender creating officer (Procurement Officer Administrator) and published by the Officer Inviting Tender (Procurement Officer Publisher) using their DSCs in appropriate format so that the document is not tampered with
- b. The tender document comprise the notice inviting tender, bid document/ SBD, drawings in .pdf format and the schedule of quantities / BoQ in .xls format to be uploaded by the Officer Inviting Tender.

c. Procurement Officer Administrator creates tender by filling up the following forms:

- i. BASIC DETAILS
- ii. COVER CONTENT: The Procurement officer Administrator should briefly describe the name and type of documents to be uploaded by the bidder in the following format:

(a) For Double cover/Package:

Sl No	Cover Type	Document Description	Type
1	Fee/ Prequal/ Technical/ Finance	Tender Cost, EMD, VAT, PAN, Contractor RC	.pdf
		Affidavits, undertakings and any other document as per SBD/DTCN.	.pdf
		BoQ	.xls

(b) For Two Cover/Package:

Sl No	Cover Type	Document Description	Type
1	Fee/ Prequal/ Technical	Tender Cost, EMD, VAT, PAN, Contractor RC	.pdf
		Affidavits, undertakings and any other document as per SBD/DTCN.	.pdf
2	Finance	BoQ	.xls
		Special condition if any specifically mentioned by Officer Inviting Tender	.pdf

- iii. TENDER DOCUMENT: The Procurement Officer Administrator should upload the NIT in .pdf format.
- iv. WORK ITEM DETAILS
- v. FEE DEATILS: The Procurement Officer Administrator should mention the cost of tender paper and EMD amount as laid down in DTCN/SBD.
- vi. CRITICAL DATES: The Procurement Officer Administrator should mention the critical dates of tender such as publishing date, document download start date & end date, seek clarification start date & end date (optional), bid submission start date & closing date, bid opening date as per DTCN/SBD.
- vii. BID OPENER SELECTION: The Procurement Officer creator can select two / three / four bid openers for a particular bid. If required the bid openers can also be selected within an organization from other procurement units (Circles /Divisions).
- viii. WORK ITEM DOCUMENTS: The Procurement Officer Administrator should upload the digitally signed tender document (SBD/DTCN) or any other addition document/drawings in .pdf format and Bill of Quantities in .xls format.
- ix. PUBLISHING OF TENDER: The Procurement Officer Publisher shall publish the tender using his/her DSC after detail scrutiny of the fields created and documents uploaded by the Procurement Officer Administrator. Procurement Officer Publisher can publish tenders for multiple procurement units using multiple DSCs procured for each post separately. After being relieved from the additional charges he has to surrender the additional DSCs to the Nodal Officer of the concerned organisation.

15. **PARTICIPATION IN BID:**

a. **PORTAL REGISTRATION:** The Contractor/Bidder intending to participate in the bid is required to register in the portal using his/her active personal/official e-mail ID as his/her Login ID and attach his/her valid Digital signature certificate (DSC) to his/her unique Login ID. He/She has to submit the relevant information as asked for about the firm/contractor. The portal registration of the bidder/firm is to be authenticated by the State Procurement Cell after verification of original valid certificates/documents such as (i) PAN and (ii) Registration Certificate (RC) / VAT Clearance Certificate (for procurement of goods) of the concerned bidder. The time period of validity in the portal is at par with validity of RC/ VAT Clearance. Any change of information by the bidder is to be re-authenticated by the State Procurement Cell. After successful authentication bidder can participate in the online bidding process.

- i. Bidders participating through Joint Venture shall declare the authorised signatory through Memorandum of Understanding duly registered and enrol in the portal in the name and style of the Joint venture Company. It is mandatory that the DSC issued in the name of the authorised signatory is used in the portal.
- ii. Any third party/company/person under a service contract for operation of e-Procurement system in the State or his/their subsidiaries or their parent companies shall be ineligible to participate in the procurement process that are undertaken through the e-Procurement system irrespective of who operates the system.

b. **LOGGING TO THE PORTAL:** The Contractor/Bidder is required to type his/her *Login ID* and password. *The system will again ask to select the DSC and confirm it with the password of DSC as a second stage authentication.* For each login, a user's DSC will be validated against its date of validity and also against the Certificate Revocation List (CRL) of respective CAs stored in system database. The system checks the unique Login ID, password and DSC combination and authenticates the login process for use of portal.

c. **DOWNLOADING OF BID:** The bidder can download the tender of his choice and save it in his system and undertake the necessary preparatory work off-line and upload the completed tender at his convenience before the closing date and time of submission.

d. **CLARIFICATION ON BID:** The bidder may ask question related to tender online in the e-procurement portal using his/her DSC; provided the questions are raised within the period of seeking clarification as mentioned in tender call notice/Bid. The Officer Inviting the Bid / Procurement Officer-Publisher will clarify queries related to the tender.

e. **PREPARATION OF BID**

- i. The bids may consist of general arrangements drawings or typical or any other drawings relevant to the work for which bid has been invited. Bidder may download these drawings and takeout print for detail study and preparation of his bid. Any other drawings and documents pertaining to the works available with the Officer Inviting The bid will be open for inspection by the bidders.
- ii. The Bidder shall go through the Bid carefully and list the documents those are asked for submission. He shall prepare all documents including cost of Bid Document, Bid Security, Declaration form, price bid etc. and store in the system.

f. **PAYMENT OF EMD/BID SECURITY AND COST OF BID DOCUMENTS:**

- i. The Bidder shall furnish, as part of his Bid, a Bid security for the amount mentioned under NIT/Contract Data. The bidder shall scan all the written/printed pages of the bid security and up load the same in portable document format (PDF) to the system in designated place of the technical BID. Furnishing scanned copy of such documents is mandatory otherwise his/her bid shall be declared as non-responsive and liable for rejection.
- ii. The EMD or Bid Security payable along with the bid is 1% of the estimated contract value (ECV) or as mentioned in the bid document. The validity period of the EMD or Bid Security shall be as mentioned in the bid document. Any bid not accompanied by an acceptable Bid Security and not secured as indicated in the bid document shall be rejected as non-responsive. The bid security shall be retained till such time the successful bidder furnishes Initial Security Deposit (ISD) or Performance Security acceptable to the Officer

Inviting the Bid. Failure of the successful Bidder to comply with the requirements shall constitute sufficient grounds for cancellation of the award and forfeiture of the Bid Security. The Bid security in the form of FD / BG shall be from a Nationalized Bank valid for a period of 45 days beyond the validity of the bid. Bid security in other form is acceptable if the bid documents provides for it.

- iii. The Fixed Deposit / Bank Guarantee or any other form as mentioned in detailed tender call notice in respect of Earnest Money Deposit / Bid Security and the Bank Draft in respect of cost of Bid are to be scanned and up loaded in portable document format (PDF) along with the bid.
- iv. The tender accepting authority will verify the originals of all the scanned documents of the successful lowest bidder only within 5 days of opening of the tender. In the eventuality of failure on the part of the lowest successful bidder to produce the original documents, he will be debarred in future from participating in tender for 3 years and will be black listed by the competent authority.
- v. Contractor exempted from payment of EMD will be able to participate in the tender directly by uploading documentary evidences towards his eligibility for such exemption
- vi. Government of Odisha has been actively considering integrating e-payment gateway in to the portal for payment of Cost of Bid and Bid Security/ Earnest Money Deposit. The process of using e-payment gateway shall be issued separately after it is established.

**16. SUBMISSION OF BID:**

- a. The bidder shall carefully go through the tender and prepare the required documents. The bid shall have a Technical Bid & a Financial Bid. The Technical bid generally consist of cost of Bid documents, EMD/ Bid Security, VAT, PAN / TIN, Registration Certificate, Affidavits and any other information required by OIT. The Financial Bid shall consist of the Bill of Quantities (BOQ) and any other price related information/undertaking including rebates.
- b. Bidders are to submit only the original BoQ (in .xls format) uploaded by Procurement Officer Publisher (Officer Inviting Tender) after entering the relevant fields without any alteration/ deletion / modification. Multiple BoQ submission by bidder shall lead to cancellation of bid. In case of item rate tender, bidders shall fill in their rates other than zero value in the specified cells without keeping it blank. In the percentage rate tender the bidder quoting zero percentage is valid and will be taken at par with the estimated rate of the work put to tender.
- c. The bidder shall upload the scanned copy/copies of document in support of eligibility criteria and qualification information in prescribed format in Portable Document Format (PDF) to the portal in the designated locations of Technical Bid.
- d. The bidder shall write his name in the space provided in the specified location in the Protected Bill of Quantities (BoQ) published by the Officer Inviting Tender. The bidder shall type rates in figure only in the rate column of respective item(s) without any blank cell in the rate column in case of item rate tender and type percentage excess or less up to two decimal place only in case of percentage rate tender.
- e. The bidder shall log on to the portal with his/her DSC and move to the desired tender for up loading the documents in appropriate place one by one simultaneously checking the documents.
  - i. Bids cannot be submitted after due date and time. The bids once submitted can not be viewed, retrieved or corrected. The Bidder should ensure correctness of the bid prior to uploading and take print out of the system generated summary of submission to confirm successful uploading of bid. The bids cannot be opened even by the OIT or the Procurement Officer Publisher/ opener before the due date and time of opening.
  - ii. Each process in the e-procurement is time stamped and the system can detect the time of log in of each user including the Bidder.
  - iii. The Bidder should ensure clarity/legibility of the document uploaded by him to the portal.
  - iv. The system shall require all the mandatory forms and fields filled up by the contractor during the process of submission of the bid/tender.
  - v. The bidder should check the system generated confirmation statement on the status of the submission.

- vi. The Bidder should upload sufficiently ahead of the bid closure time to avoid traffic rush and failure in the network.
- vii. The Tender Inviting Officer is not responsible for any failure, malfunction or breakdown of the electronic system used during the e-procurement process.
- viii. The Bidder is required to upload documents related to his eligibility criteria and qualification information and Bill of Quantity duly filled in. It is not necessary for the part of the Bidder to up-load the drawings and the other Bid documents (after signing) while uploading his bid. It is assumed that the bidder has referred all the drawings and documents uploaded by the Officer Inviting the Bid.
- ix. The Bidder will not be able to submit his bid after expiry of the date and time of submission of bid (server time). The date and time of bid submission shall remain unaltered even if the specified date for the submission of bids declared as a holiday for the Officer Inviting the Bid.

f. **SIGNING OF BID:** The 'online bidder' shall digitally sign on all statements, documents, certificates uploaded by him, owning responsibility for their correctness / authenticity as per IT ACT 2000. If any of the information furnished by the bidder is found to be false / fabricated / bogus, his EMD/Bid Security shall stand forfeited & his registration in the portal shall be blocked and the bidder is liable to be blacklisted.

17. **SECURITY OF BID SUBMISSION:**

- a. All bid uploaded by the Bidder to the portal will be encrypted.
- b. The encrypted Bid can only be decrypted / opened by the authorised openers on or after the due date and time.

18. **RESUBMISSION AND WITHDRAWAL OF BIDS:**

- a. Resubmission of bid by the bidders for any number of times before the final date and time of submission is allowed.
- b. Resubmission of bid shall require uploading of all documents including price bid afresh.
- c. If the bidder fails to submit his modified bids within the pre-defined time of receipt, the system shall consider only the last bid submitted.
- d. The bidder should avoid submission of bid at the last moment to avoid system failure or malfunction of internet or traffic jam or power failure etc.
- e. The Bidder can withdraw his bid before the closure date and time of receipt of the bid by uploading scanned copy of a letter addressing to the Procurement Officer Publisher (Officer Inviting Tender) citing reasons for withdrawal. The system shall not allow any withdrawal after expiry of the closure time of the bid.

19. **OPENING OF THE BID:**

- a. Bid opening date and time is specified during tender creation or can be extended through corrigendum. Bids cannot be opened before the specified date & time.
- b. All bid openers have to log-on to the portal to decrypt the bid submitted by the bidders.
- c. The bidders & guest users can view the summary of opening of bids from any system. Contractors are not required to be present during the bid opening at the opening location if they so desire.
- d. In the event of the specified date of bid opening being declared a holiday for the Officer Inviting the Bid, the bids will be opened at the appointed time on the next working day.
- e. Combined bid security for more than one work is not acceptable.
- f. The electronically submitted bids may be permitted to be opened by the predefined Bid opening officer from their new location if they are transferred after the issue of Notice Inviting Bid and before bid opening. Further, action on bid documents shall be taken by the new incumbent of the post.

g. In case of non-responsive tender the officer inviting tender should complete the e-Procurement process by uploading the official letter for cancelled / re-tender.

## 20. EVALUATION OF BIDS :

- a. All the opened bids shall be downloaded and printed for taking up evaluation. The officer authorized to open the tender shall sign and number on each page of the documents downloaded and furnish a certificate that “the documents as available in the portal containing \_\_\_\_\_ nos. of pages”.
- b. The bidder may be asked in writing/ online (in their registered e-mail ids) to clarify on the uploaded documents provided in the Technical Bid, if necessary, with respect to any doubts or illegible documents. The Officer Inviting Tender may ask for any other document of historical nature during Technical Evaluation of the tender. Provided in all such cases, furnishing of any document in no way alters the Bidder’s price bid. Non submission of legible documents may render the bid non-responsive. The authority inviting bid may reserve the right to accept any additional document.
- c. The bidders will respond in not more than 7 days of issue of the clarification letter, failing which the bid of the bidder will be evaluated on its own merit.
- d. The Technical evaluation of all the bids shall be carried out as per information furnished by Bidders.
- e. The Procurement Officer-Evaluators; will evaluate bid and finalize list of responsive bidders.
- f. The financial bids of the technically responsive bidders shall be opened on the due date of opening. The Procurement Officer-Openers shall log on to the system in sequence and open the financial bids.
  - i. The Financial Bid will be opened on the notified date & time in the presence of bidders or their authorised representative who wish to be present.
  - ii. At the time of opening of “Financial Bid”, bidders whose technical bids were found responsive will be opened.
  - iii. The responsive bidders’ name, bid prices, item wise rates, total amount of each item in case of item rate tender and percentage above or less in case of percentage rate tenders will be announced.
  - iv. Procurement Officer-Openers shall sign on each page of the downloaded BOQ and the Comparative Statement and furnish a certificate to that respect.
  - v. Bidder can witness the principal activities and view the documents/summary reports for that particular work by logging on to the portal with his DSC from anywhere.
  - vi. System provides an option to Procurement Officer Publisher for reconsidering the rejected bid with the approval of concern Chief Engineer / Head of Department.

## 21. NEGOTIATION OF BIDS:

- a. For examination, evaluation, and comparison of bids, the officer inviting the bid may, at his discretion, ask the lowest bidder for clarification of his rates including reduction of rate on negotiation and breakdown of unit rates.

## 22. NOTIFICATION OF AWARD AND SIGNING OF AGREEMENT:

- a. The Employer/Engineer-in-Charge shall notify acceptance of the work prior to expiry of the validity period by cable, telex or facsimile or e-mail confirmed by registered letter. This Letter of Acceptance will state the sum that the Engineer-in-Charge will pay the contractor in consideration of execution & completion of the Works by the contractor as prescribed by the contract & the amount of Performance Security and Additional Performance Security required to be furnished. The issue of the letter of Acceptance shall be treated as closure of the Bid process and commencement of the contract.

- b. The Contractor after furnishing the required acceptable Performance Security & Additional Performance Security, “Letter to Proceed” or “Work Order” shall be issued by the Engineer-in-Charge with copy thereof to the Procurement Officer –Publisher. The Procurement Officer-Publisher shall up load the summary and declare the process as complete.
- c. If the L-1 bidder does not turn up for agreement after finalization of the tender, then he shall be debarred from participation in bidding for three years and action will be taken to blacklist the contractor. Besides the consortium / JV / firm where such an agency / firm already happens to be or is going to be a partner/member/proprietor, he/ they shall neither be allowed for participation in bidding for three years nor his/ their application will be considered for registration and action will be initiated to blacklist him / them and the tender will be cancelled.

**23. BLOCKING OF PORTAL REGISTRATION:**

- a. If the Registration Certificate of the Contractor is cancelled /suspended by the registering authority/ blacklisted by the competent authority his portal registration shall be blocked automatically on receipt of information to that effect.
- b. The portal registration blocked in the ground mentioned in the above Para-23. a shall be unblocked automatically in receipt of revocation order of cancellation / suspension/ blacklisting from the concerned authority.
- c. The Officer Inviting Tender shall make due inquiry and issue show cause notice to the concerned contractor who in turn shall furnish his reply, if any, within a fortnight from the date of issue of show cause notice. Thereafter the Officer Inviting Tender is required to issue an intimation to the defaulting bidder about his unsatisfactory reply and recommend to the Chief Manager (Tech.) for blocking of portal registration within 10 days of intimation to the defaulting bidder regarding his unsatisfactory reply with intimation to the Registering Authority and concerned Chief Engineer/ Heads of Office if any of the following provisions are violated.
  - i. Fails to furnish original Technical / Financial (Tender Paper Cost, EMD/Bid Security) instruments before the designated officer within the stipulated date and time.
  - ii. Backs out from the bid on any day after the last date of receipt of tender till expiry of the bid validity period.
  - iii. Fails to execute the agreement within the stipulated date.
  - iv. If any of the information furnished by the bidder is found to be false / fabricated / bogus.

Accordingly the Officer Inviting Tender shall recommend to the Chief Manager (Tech.), State Procurement Cell, Odisha for blocking of portal registration of bidder and simultaneously action shall also be initiated by OFFICER INVITING TENDER for blacklisting as per Appendix- XXXIV of OPWD Code, Volume-II.

**24. GUIDELINES FOR UNBLOCKING OF PORTAL REGISTRATION:**

**a. UNBLOCKING OF PORTAL REGISTRATION:**

Unblocking of portal registration of a contractor shall be done by a Committee consisting of the following members.

EIC (Civil)-cum-CPO,	-	Chairman
Engineer-in-Chief (WR)	-	Member
Concerned Chief Engineer	-	Member
Sr. Manager (Finance), SPC	-	Member
Officer Inviting Tender	-	Member
Chief Manager (Technical), SPC	-	Convener

- b. The Chief Manager (Tech), State Procurement Cell will be the convener and he will maintain all records for this purpose. The Committee shall meet not less than once in a month if required & shall consider the recommendation of the officer inviting tender for unblocking of portal registration. The quorum of the meeting will be four.
- c. The minimum period of blocking of Portal Registration shall in no case be less than 90 days. After blocking of Portal Registration, the Contractor whose Portal Registration has been blocked may file application to the concerned officer inviting tender showing sufficient ground for unblocking of his portal registration along with a Treasury Challan showing deposit of Rs. 10,000/- (Rupees ten thousand) only (non-refundable) under the head of accounts ‘0059 -

Public Works' as processing fees. The officer inviting tender shall forward the application filed by the contractor to the Chief Manager (Tech), State Procurement Cell.

- d. On receipt of recommendation from the concerned Chief Engineer along with the copy of challan as mentioned above, the Chief Manager (Tech) being the member Convener of the Committee shall place the case before the Committee for examination and taking a decision in this regard. After examination the Committee may recommend for unblocking of the portal registration of said contractor if the Committee is satisfied that the fault committed by the contractor is either unintentional or done for the first time.
- e. After scrutiny by the State Procurement Cell if it is found that the portal registration of a contractor has been blocked for the 2<sup>nd</sup> time the Chief Manager (Tech), SPC may not consider his case to be placed before the Committee and may advise the concerned officer inviting tender to issue show cause notice to the contractor asking him to explain as to why his portal registration shall not remain blocked. On receipt of show cause reply from the contractor the officer inviting tender shall examine the same & if considered proper he may report to the Chief Manager (Tech), SPC along with his views furnishing the copy of the show cause reply for placement of the same before the Committee for taking a decision in respect of blocking/ unblocking. If the Committee found that the contractor is in habit of committing such fault again and again intentionally the committee may advise the concerned officer inviting tender to initiate proceeding for blacklisting as per the existing rule.
1. These amendments shall take effect from the date of issue of the order.
  2. This amendment is an addition to the existing provision and will be placed below Appendix-IX to OPWD Col, Vol-II.
  3. Accordingly Office Memorandum No.1027 dt.24.01.2009 stands modified.
  4. This has been concurred in by the Finance Department vide their UOR No.3-WF-1 dt.04.01.2013.

*Sd/19.07.2013*

**E.I.C-cum-Secretary to Govt.**

Appendix – II

**Online Receipt of Tender Paper Cost & Earnest Money Deposit  
through e-Procurement Portal  
as per Works Department Letter No.17276/W Dt.06.12.2017**

**Government of Odisha  
Works Department**

\*\*\*

Office Memorandum

File No.07556900012016–17254/W Dt.05.12.2017

**Sub: Electronic receipt, accounting and reporting of Cost of Tender Paper and Earnest Money Deposit on submission of bids.**

1. The State Government have formulated rules and procedures for Electronic receipt, accounting and reporting of the receipt of Cost of Tender Paper and Earnest Money Deposit on submission of bids through the e-procurement portal of Government of Odisha i.e. "<https://tendersodisha.gov.in>".
2. Electronic receipt of cost of tender paper has been successfully tested through SBI payment gateway. Now it has been decided to introduce electronic receipt of **Cost of Tender Paper and Earnest Money Deposit on submission of bids** through payment gateway of designated banks such as **SBI/ICICI Bank/HDFC Bank** for all Government Departments, State PSUs, Statutory Corporations, Autonomous Bodies and Local Bodies etc. in phases (ANNEXURE-I). The process outline as well as accounting and reporting structure are indicated below :
  - a) It will be carried out through a single banking transaction by the bidder for multiple payments like **Cost of Tender Paper and Earnest Money Deposit on submission of bids**.
  - b) Various payment modes like **Internet banking/ NEFT/RTGS** of Designated Banks and their Aggregator Banks as well can be accessed by the intending bidders.
  - c) Reporting and accounting of the **e-receipts** will be made from a single source.
  - d) Credit of receipts into the Government accounts and to the designated Bank account of the participating entities indicated in Para 2 above would be faster.
3. Only those bidders who successfully remit their **Cost of Tender Paper and Earnest Money Deposit on submission of bids would be eligible to** participate in the tender/bid process. The bidders with pending or failure payment status shall not be able to submit their bid. Tender inviting authority, State Procurement Cell, NIC, the designated Banks shall not be held responsible for such pendency or failure.
4. **Banking arrangement:**
  - a) Designated Banks (**SBI/ICICI Bank/HDFC Bank**) payment gateway are being integrated with e-Procurement portal of Government of Odisha (<https://tendersodisha.gov.in>)
  - b) The Designated Banks participating in **Electronic receipt, accounting and reporting of Cost of Tender Paper and Earnest Money Deposit on submission of bids** will nominate a **Focal Point Branch** called e-FPB, who is authorized to collect and collate all e-Receipts. Each such branch will act as the Receiving branch and Focal Point Branch notwithstanding the fact that the bidder might have debited his account in any of the bank's branches while making payment.
5. **Procedures of bid submission using electronic payment of tender paper cost and EMD by bidder:**
  - a) **Log on to e-Procurement Portal:** The bidders have to log onto the Odisha e-Procurement portal (<https://tendersodisha.gov.in>) using his/her digital signature certificate and then search and then select the required

active tender from the "Search Active Tender" option. Now, submit button can be clicked against the selected tender so that it comes to the "My Tenders" section.

- b) **Uploading of Prequalification/Technical/Financial bid:** The bidders have to upload the required Prequalification /Technical/Financial bid, as mentioned in the bidding document and in line with Works Department office memorandum no.7885, dt.23.07.2013.
- c) **Electronic payment of tender paper cost and EMD:** Then the bidders have to select and submit the bank name as available in the payment options
  - i. A bidder shall make electronic payment using his/her **internet banking** enabled account with designated Banks or their aggregator banks.
  - ii. A bidder having account in other Banks can make payment using **NEFT/RTGS** facility of designated Banks.
    - Online NEFT/RTGS payment using internet banking of the bank in which the bidder holds his account, by adding the account number as mentioned in the challan as an interbank beneficiary.
- d) **Bid submission:** Only after receipt of intimation at the e-Procurement portal regarding successful transaction by bidder the system will activate the 'Freeze Bid Submission' button to conclude the bid submission process.
- e) **System generated acknowledgement receipt for successful bid submission:** System will generate an acknowledgement receipt for successful bid submission. The bidder should make a note of '**Bid ID**' generated in the acknowledgement receipt for tracking their bid status.

#### 6. Settlement of Cost of Tender Paper;

- a) **Cost of Tender Paper:** In respect of Government receipts on account of **Cost of Tender Paper**, the e-Procurement portal shall generate a MIS for the State Procurement Cell (SPC). The MIS will contain an abstract of the cost of tender paper collected with reference to **Bid Identification Number**. The State Procurement Cell shall generate Bank-wise-head-wise challans separately for **Cost of Tender Paper** and instruct the designated Banks to remit the money to the State Government account under different heads. In respect of the cost of tender paper received through the e-procurement portal, the remittance to the Cyber Treasury account will be made to the Head of Account 0075-Misc, General Services-800-Other Receipts -0097-Misc. Receipts-02237-Cost of Tender Paper.
- b) For the time being, the State Procurement Cell (SPC) will use over the counter payment facility of the Odisha Treasury portal. Thereafter, remittance through NEFT & RTGS will be facilitated through the Odisha Treasury portal.
- c) Similarly, in case of State PSUs, Statutory Corporations, Autonomous Bodies and Local Bodies etc., **Cost of Tender Paper**, the e-Procurement portal shall generate a MIS for the State Procurement Cell (SPC). The MIS will contain an abstract of the cost of tender paper collected with reference to **Bid Identification Number**. The State Procurement Cell shall generate Bank-wise list of challans and instruct the designated Banks to remit the money through the Odisha Treasury portal. The cost of tender papers will be credited to the registered Bank account of the concerned State PSUs, Statutory Corporations, Autonomous Bodies and Local Bodies etc.
- d) Bank will refund (in case the Tender Inviting Authority (TIA) issues such instructions) the tender fee, EMD to the bidder, in case the tender is cancelled before opening of Bid as per direction received from TIA through e-procurement system.
- e) Back-end Transaction Matrix of Electronic receipt of Cost of Tender Paper and Earnest Money Deposit on submission of bids is enclosed in the Annexure.

**7. Settlement of Earnest Money Deposit on submission of bids:**

- a) The Bank will remit the **Earnest Money Deposit on submission/ cancellation of bids** to respective bidders accounts as per direction received from TIA through e-procurement system.

**8. Forfeiture of EMD :**

Forfeiture of **Earnest Money Deposit on submission of bid** of defaulting bidder is occasioned for various reasons.

- a) In case the **Earnest Money Deposit on submission of bid** is forfeited, the e-Procurement portal will direct the Bank to transfer the EMD value from the Pooling Account of SPC to the registered account of the tender inviting authority.
- b) The Tender inviting authorities of the Government Departments will deposit the forfeited **Earnest Money Deposit on submission of bid**, in the State Government Treasury under the appropriate head (8782-Cash Remittances and Adjustments between the officers rendering accounts to the same Accounts Officer-102-P.W.Remittances-1683-Remittances-91028-Remittances into Treasury) after taking the amount as a revenue receipt in their Cash Book under the head 0075-Misc. General Services-00-101 -Unclaimed Deposits-0097-Misc, Receipts-02080-Misc. Deposits and submit the detail account to DAG (Puri) as a deposit of the Division.
- c) By clicking submit button, system will initiate the forfeiture of EMD. System will not allow the evaluator to edit the initiation after clicking the submit button. Forfeiture option can be carried out in phased manner like one bidder at a time.

**9. Role of the Banks:**

- a) Make necessary provision / customizations at their end to enable the provision for online payments / refunds as per this document.
- b) Provide necessary real-time message to bidders regarding successful or unsuccessful transactions during online payment processes and redirect them to e-Procurement website with necessary transaction reference details enabling them to submit their bids.
- c) The bank shall ensure transfer of funds from the pooling account to the Government Head/current account of PSUs/ULBs within the next bank working day as per the directions generated from e-Procurement portal.
- d) Bank should provide timely reports and reference details to NIC enabling them to carry out their role as stated below.
- e) Refund of amount to bidders as per the XML file provided by e-Procurement system on the next bank working day from the date of generation of the XML file and also provide a confirmation to NIC on the same.

**10. Role of State Procurement Cell:**

- a) Communicate requirements of Government departments/ State PSUs/ Autonomous Bodies/ ULBs online payment requirements to National Informatics Centre / the authorised Banks for mapping/ customization.
- b) In every working day, the State Procurement Cell shall generate MIS from the e-Procurement portal to ascertain the tender paper cost received in the e-Tendering process separately bank-wise for the Government Department and the PSUs/ULBs. The SPC shall generate bank-wise separate online challans from the Odisha Treasury portal and make the remittance through over the counter facility or NEFT/RTGS (as and when this functionality is available in Treasury portal) and issue instruction to the bank for remittance of the receipt to the State Government account.
- c) The State Procurement Cell shall be responsible for providing challan details and MIS in respect of the remittance towards tender paper cost to the Tender inviting authorities for their record.
- d) State Procurement Cell shall monitor the progress of e-Tendering by different Government departments / State PSUs/ Autonomous Bodies / ULBs through an MIS. State Procurement Cell shall monitor and send monthly progress reports to the Government.

- e) The e-Procurement system will generate a consolidated refund & settlement XML file as an end of the day activity.
- f) e-procurement system will provide a web service for payment gateway (PG) provider to pull the encrypted refund and settlement details in XML file against a day.
- g) Similarly, payment gateway (PG) provider will provide a web service to pull the refund and settlement status against a day
- h) e-procurement system will update the status accordingly for reconciliation report.

**11. Role of National Informatics Centre :**

- a) Customize e-Procurement software and web-pages of Government of Odisha (<https://tendersodisha.gov.in>) to enable the provision for electronic payment.
- b) The NIC, Odisha will modify / rectify the errors in electronic data relating to the Chart of Account.
- c) NIC will provide an interface to organisations to download the electronic receipt data.
- d) Enable automatic generation of daily XML files from e-Procurement system and ensure delivery of the same to the authorised Banks for enabling automatic refund/settlement of funds.
- e) NIC shall enable the e-Procurement portal to generate MIS as required for the State Procurement Cell in order to make remittance of the tender paper cost to the State Government account using the Odisha Treasury portal.

**12. Role of Cyber Treasury :**

- a) The cost of the tender paper deposited by the SPC using the Odisha Treasury Portal which will be accounted for by the Cyber Treasury and it shall submit the accounts to A.G (O) as per the established process.
- b) The Cyber Treasury will provide MIS as required to the SPC for the purpose of accounting and reconciliation of the electronic remittances made to the State Government account.

**13. Redressal of Public grievances :**

- a) The State Procurement Cell, Odisha, National Informatics Centre, Odisha and the e-FPB will have an effective procedure for dealing with, public complaint for e-Receipt related matters. In case, any mistake is detected by any of the stakeholders in reporting of receipt of tender paper cost and EMD, either suo moto or on being brought to its notice, the State Procurement Cell, Odisha, National Informatics Centre, Odisha unit, Cyber Treasury and the bank will promptly take steps for rectification. The e-Focal Point Branch of the participating Banks, National Informatics Centre, Odisha and the State Procurement Cell, Odisha will notify the contact number and address of the Help Desk for resolution of any dispute regarding e-Receipt.

**14. Applicability and modification of existing rules / orders:**

The modalities prescribed in this Office Memorandum for downloading of tender paper, submission and rejection of bid, acceptance of Bids as well as refund and forfeiture of earnest deposit will be applicable for electronic submission of bids through e-procurement portal. Existing provisions regulating cost of tender paper, earnest money deposit in OPWD Code and OGFR would stand modified to the extent prescribed.

**15. These arrangements would be made effective after signing of MOU between the designated Banks and the State Procurement Cell, firming up of Banking arrangements and technical integration between designated Bank and e-Procurement Portal.**

1. This shall take effect from the date of issue of this Office Memorandum.
2. Accordingly, relevant existing codal/ contractual provision exist vide Office Memorandum No.6785/W Dt.09.05.2017 of Works Department stands modified to the above extent.
3. This has been concurred in by the Finance Department vide their UOR No.-39-WF-I Dt.09.11.2017.

*Sd/05.12.2017*

**E.I.C-cum-Secretary to Govt.**

**[For any Technical related queries please call at Help desk numbers of State Procurement Cell (SPC), Govt. of Odisha – 1800 3456 765, 0674-2530998, 2530996]**

ANNXURE-I of Appendix - II

**Back-end Transaction Matrix of Electronic receipt and remittance of Cost of Tender Paper and Earnest Money Deposit on submission of bids.**

	<b>Cost of Tender Paper on submission of bids</b>	<b>Earnest Money Deposit on submission of bids</b>
Government Departments	<p>I. The payment towards the <b>cost of Tender Paper</b>, in case Government Departments, shall be collected in separate Pooling accounts opened in Focal Point Branch called e-FPB of respective designated banks [as stated in Para 2] at Bhubaneswar on T+1_day.</p> <p>II. With reference to the Notice Inviting Tender/ Bid Identification Number, the amount so realized is to be remitted to Government Account under the Head Of Account 0075-Misc. General Services-800-Other Receipts-0097-Misc. Receipts-02237-Cost of Tender Paper through Odisha Treasury Portal after opening of the bid.</p>	<p>I. In case of tenders of Government Departments, amount towards <b>Earnest Money Deposit</b> on submission of bids shall be collected in a pooling account opened for this purpose at Focal Point Branch called e-FPB of respective designated banks at Bhubaneswar and the banks will remit the amount to respective bidder's account within two working days on receipt of instruction from TIA through refund and settlement of e-procurement system.</p> <p>II. In case of forfeiture of <b>Earnest Money Deposit</b> on submission of bids, the e-Procurement portal will direct the Bank to transfer the EMD value from the Pooling Account of SPC to the registered account of the tender inviting authority within two working days of receipt of instruction from TIA.</p>
State PSUs Statutory Corporations, Autonomous Bodies and Local Bodies.	<p>I. In case of State PSUs, Statutory corporations, Autonomous Bodies and Local Bodies etc. the amount towards <b>Cost of Tender Paper</b>, on submission of bids shall be collected in separated pooling accounts opened in Focal Point Branch called e-FPB of respective designated Banks at Bhubaneswar on T+1 days.</p> <p>II. The <b>Paper cost</b> will be transferred to the respective current accounts of concerned State PSUs, Statutory Corporation, Autonomous Bodies and Local Bodies etc. after opening of bid.</p>	<p>I. Amount towards <b>EMD</b> on submission of bids shall be collected in a separate pooling account of Focal Point Branch called e-FPB of respective designated banks at Bhubaneswar and the banks will remit the amount to respective bidder's account on receipt of instruction from TIA through refund and settlement of e-procurement system within two working days from receipt of such instruction.</p> <p>II. In case of forfeiture of <b>Earnest Money deposit</b> on submission of bids, the e- Procurement portal will direct the Bank to transfer the EMD value from the Pooling Account of SPC to the registered account of the tender inviting authority within two working days of receipt of instruction from TIA.</p>

**OFFICE OF THE  
LABOUR COMMISSIONER, ODISHA, BHUBANESWAR**

+++

**NOTIFICATION**

**No 3920 /Dated 01.05.2026**

Whereas as per Notification No. 5308 dated 18.07.2024 issued by the Labour & ESI Department, Government of Odisha, the minimum rate of wages have been revised in the scheduled employments for unskilled, semi-skilled, skilled and highly skilled categories of workers working in the State, published in the Odisha Gazette vide Notification No. 1367 dated 18.07.2024;

Whereas as per the said notification, a special Variable Dearness Allowance (VDA) is declared twice a year i.e. on 1st April and on 1st October @ Rs. 2.60 per point increase in the Consumer Price Index Number for industrial workers (base 2016=100) by the Labour Commissioner, Odisha;

Whereas during the last half-year, the Consumer Price Index for industrial workers has increased from 143.58 to 147.50 on an average and thereby increased by 3.92 points and accordingly, it is necessary to increase the Variable Dearness Allowance (VDA) on the said basis for the half-year starting from 1st April, 2026;

Therefore, I, Shri Indramani Tripathy, IAS, Labour Commissioner, Odisha, in exercise of the power conferred by the above notification, hereby notify that the Variable Dearness Allowance (VDA) for unskilled, semi-skilled, skilled and highly skilled categories of employees in all 91 scheduled employments (as per enclosed list) has been increased by an amount of Rs. 10/- per day with effect from 1st April, 2026, in addition to the Variable Dearness Allowance (VDA) declared earlier. Accordingly, the minimum rate of wages with variable dearness allowance from 1st April 2026 shall be as follows:

Category of employees	Daily minimum rate of wages prior to 01.04.2026 (with VDA)	Increase in VDA per day w.e.f. 01.04.2026	Daily minimum rate of wages with VDA w.e.f. 01.04.2026
Unskilled	Rs. 462/-	Rs. 10/-	Rs. 472/-
Semi-skilled	Rs. 512/-	Rs. 10/-	Rs. 522/-
Skilled	Rs. 562/-	Rs. 10/-	Rs. 572/-
Highly Skilled	Rs. 612/-	Rs. 10/-	Rs. 622/-

Labour Commissioner, Odisha

## **SECTION – 4**

# **GENERAL RULES & DIRECTIONS**

**ODISHA PUBLIC WORKS DEPARTMENT (FORM P-1)**

**PERCENTAGE RATE TENDER AND CONTRACT FOR WORKS GENERAL RULES & DIRECTIONS FOR THE GUIDANCE OF CONTRACTORS**

1. The work proposed for execution by contract will be notified in a form of invitation to tender posted through Govt. website [www.tendersodisha.gov.in](http://www.tendersodisha.gov.in)

This notice will state the work to be carried out, the items and approximate quantities thereof as well as the date for submitting and opening tenders also the amount of earnest money to be deposited and the amount of the security deposit by the successful tenderer and the percentage if any to be deducted from bills. Copies of the specifications, designs and drawings and any other documents required in connection with the submission of tender signed for the purpose of identification by the Sub-divisional Officer/Superintending Engineer shall also be open for inspection by the contractor at the office of the Sub-Divisional Officer/ Superintending Engineer during office hours.

2. In the event of the tender being submitted by a firm it must be signed separately by each member thereof, or in the event of the absence of any partner, it must be signed on his behalf by a person holding a power of attorney authorizing him to do so.
3. Receipts for payment made on accounts of works, when executed by a firm must also be signed by the several partners, except where the contractors are described in their tenders as a firm in which case the receipts must be signed in the name of the firm by one of the partners, or by some other person having authority to give effectual receipts for the firm.
4. The memorandum of work tendered for and the memorandum of materials to be supplied by the Public Works Departments and their issue rates shall be filled in and completed in the office of the Sub-Divisional Officer/Superintending Engineer before the tender form is issued if a form is issued to an intending tender without having been so filled in and completed, he shall request the office to have this done before he completes and delivers his tender.
5. The amount of earnest money to be remitted will be 1% (online).
6. Any person who submits a tender shall fill up the usual printed form stating at what rate he is willing to undertake each item of the work. Incomplete tender and tender rate he is willing to undertake each item of the work specified in the said form of invitation to tender or which they contain any other conditions of any sort, or omit to note the time within which the work can be finished or which are not accompanied by required earnest money will be liable to rejection. No single tender shall include more than one work, but contractors who wish to tender for two or more works shall submit a separate tender for each tender.
7. The Engineer-in-charge or his duly authorized assistant will open the tenders in the presence of any intending contractors who may be present at the time and will enter the amounts of the several tenders in a comparative statement in a suitable form.
8. The Engineer-in-charge shall have the right of rejecting all or any of the tenders.
9. In the event of a tender being selected for acceptance the Engineer who opened the tenders will, if he is competent to accept the tender, inform the tenderer of the selected

tender who shall there upon sign copies of the specification and other documents with the agreement. The tenderer of the selected tender shall also deposit the required amount of the security money within the prescribed time. If the tenderer fails to deposit the required amount of the security money within the prescribed time the Engineer-in-charge may reject the tender.

If the Engineer is not competent to accept the tender himself, he will inform the tenderer of the tender which he decides to recommend for acceptance, such tenderer shall there upon sign forthwith copies of the specification and other documents mentioned in rules 1 and 4 and shall deposit the required amount of the security money within the prescribed time. The tender with the specification and other documents signed by the tenderer will then be forwarded for acceptance to the Engineer who is competent to accept the same. If the said Engineer rejects the tender the security money deposited shall be refunded to the tenderer.

1. When a tender is selected for acceptance, the tenderer shall deposit the required amount
2. of the security money. No tender shall be finally accepted until the required amount of the security money has been deposited.
3. The amount of security money to be deposited by the tenderer whose tender is selected for acceptance shall be 2 (two) percent of the estimated value of the work, failing which tender shall be liable to rejection.

Taxes as per provisions of Government shall be deducted from the bills of tenderer.

4. When tender has been selected for acceptance and the required amount of the security money has been deposited the Engineer shall scrutinize all pages of the form of item, Rate Tendered/quoted percentage in case of percentage tender and Contract for works to see that the form has been properly filled up and signed by the contractor and the signature witnessed. He shall then, if he is competent to accept the tender, sign the acceptance of the tenders or if he is not so competent to, shall send the form for signature of the acceptance to the officer competent to accept it.
5. All tenderers are required to submit a list of works, which are in hand at the time of submitting their tenders. The list of works are required to be submitted in the proforma by the Superintending Engineer under whom he has executed the work in order to judge their past performance (vide Works Department Circular No.15443dt.01.08.2005.)
6. If the tenderer backs out from the offer before acceptance of the tender by the competent authority then he/she will be suspended for a period of three years.
7. T.D.S (Tax Deducted at Source) towards GST will be deducted at the rate prescribed in the Odisha Goods & Service Tax Act-2017 or as amended from time to time.

## TENDER FOR WORKS

I / We hereby tender for the execution for the Government of Odisha for the work specified in the under written memorandum at the rates specified therein in a period of **08 (Eight)** calendar months from the date of written order to commence and in accordance in all respects with the specifications designs and other documents referred to in rules thereof and subject to the annexed conditions of contract and with such materials as are provided for by and in all other respects in accordance with such condition so far as applicable.

### MEMORANDUM

a) If several sub-works are included they should be detailed in a separate sheet.	(a)	Name of Work	:	<b>Improvement to Right Service Bank Road of Sapua Link Channel from RD 2.100 Km to RD 5.330 Km of Sapua Badjore Irrigation Project.</b>
	(b)	Estimated Cost (Bill of Quantity)	:	<b>Rs.2,53,32,451/-</b>
	(c)	E.M.D	:	<b>Rs. 2,53,325.00</b>
d) <b>This deposit Will be 2 percent Of the estimated Cost of the work.</b>	(d)	Initial security deposit (including earnest money) to Be deposited before the Commencement of the work.	:	<b>Rs.5,06,650.00</b>
e) This percentage from bills will be credited to the contractor's security	(e)	Percentage to be deducted from bill (As Security Deposit).	:	
	(f)	Time required for the work from date of written order	:	<b>08(Eight) calendar months including rainy season</b>
	(g)	Date of written order to commence	:	
	(h)	Total number of work tendered for	:	<b>15(Fifteen) items only</b>

Signature of contractor before submission of tender

Should this tender be accepted I/We hereby agree to abide by and fulfill the terms and provision of the said condition of contract annexed here to so far as applicable, or in defaults thereof to forfeit and pay to the Governor of Odisha or his successors in office, the sum of money mentioned in the said conditions.

Dated the .....Day of .....2026

Signature of witness to one tenderer's signature

Witness :

Address:

**CONTRACTOR**

Signature of Officer by whom accepted

The above tender is hereby accepted by me on behalf of the Government of Odisha.

Dated the .....Day of .....2026

Additional Chief Engineer  
Angul Irrigation Circle, Angul

Agreement No.....P1 Certified that this agreement contains .....Pages only  
(Schedule XLV-Form No.-61)

**Superintending Engineer  
Angul Irrigation Division,Angul**

**SECTION – 5**  
**CONDITION OF CONTRACT**

# CONDITION OF CONTRACT

**Clause 1-** All compensation or other sum of money payable by the contractor to Government under the terms of his contract may be deducted from, or paid by the sale of a sufficient part of his security deposit or from the interest arising there from, or from any sums which may be due or may become due to the contractor by Government on any account whatsoever

and in the event of his security deposit being reduced by reason of any such deduction or sale

**Compensation for delay**

as aforesaid, the contractor shall within ten days thereafter make good in cash or Government securities endorsed as aforesaid any sum or sums which may have been deducted from or raised by, sale of the security deposit or any part thereof.

**Clause 2 (a)** The time allowed for carrying out the work as entered in the tender shall be strictly observed by the contractor and shall be reckoned from the date on which the written order to commence work is given to the contractor, The work shall throughout the stipulated period of the contract be carried on with all due diligence (time being deemed to be of the essence of the contract on the part of the contractor) and the contractor shall pay as compensation an amount as mentioned in clause 2.3.1 of OPWD Code of Volume-I, if the whole work as shown by the tender for every day that the work

remains un-commenced, or unfinished after the proper dates (The work should not be considered finished until such date as the

Superintending Engineer shall certify as the date on which the work is finished after necessary rectification of defects as pointed out by the Superintending Engineer, or his authorized agents are fully complied with by the contractor to the Superintending Engineer's

**The work should not be considered finished until such date as the E.E./S.E. shall certify as the date on which the work is finished after necessary rectification of defects as pointed out by E.E./S.E. or his authorized agents are fully complied with by the contractor to the E.Es/S.Es satisfaction.**

satisfaction). And further to ensure good progress during execution of the work the contractor shall be bound, in all cases in which the time allowed for any work exceeds one month, to complete one fourth of the whole work before one fourth of the whole time allowed under contract has elapsed one half of the work, before one half of such time has elapsed and three-fourth of the work before three-fourth of such time has elapsed. In the events of the contractor failing to comply with the condition, he shall be liable to pay as compensation as mentioned in clause 2.3.1 of OPWD Code of Volume-I on the said estimated cost of the whole work for every day that the due quantity of work remains incomplete, provided always that the entire amount of compensation to be paid under the provision of this clause shall not exceed 10% on estimated cost of the work as shown in the tender.

(b) If there are possibilities of exceeding this compensation amount as mentioned in clause (a) 10% of the estimated cost or in any case in which under any clause or clauses of this contract the contractor shall have tendered himself liable to pay compensation amounting to the whole of his security deposit in the hands of Govt. (whether paid in one sum or deducted by installments) the Superintending Engineer on behalf of the Governor of Odisha, shall have power to adopt any of the following courses as he may deem best suited to the interest of Government.

<b>Action when whole security deposit is forfeited</b>
--

- (i) To rescind the contract (of which rescission notice in writing to the contractor under the hand of the Superintending Engineer shall be conclusive evidence) 20% of the value of left over work will be realized from the contractor as penalty.
- (ii) To employ labour paid by the Public works Department and to supply materials to carry out the work, or any part of the work, debiting the contractor with the cost of the labour and the price of the materials ( of the amount of which cost and price certificate of the Superintending Engineer shall be final and conclusive against the contractor) and crediting him with the value of work done, in all respects in the same manner and at the same rates as if it had been carried out by contractor under the terms of his contract, the certificate of the Superintending Engineer as to the value of the work done shall be final and conclusive against the contractor
- (iii) To measure up the work of the contractor, and to take such part of the work of the contract as shall be unexecuted out of his hands and to give it to another contractor to complete, in which case any expenses which may be incurred in excess of the sum which would have been paid to the original contractor if the whole work had been executed by him (of the amount of which excess the certificate in writing of the Superintending Engineer shall be final and conclusive) shall be borne and paid by the original contractor may be deducted from any money due to him by Govt. under the contract or otherwise or from his security deposit or the proceeds of sale thereof or a sufficient part thereof.

In the event of any of the above courses being adopted by the Superintending Engineer the contractor shall have no claim to compensation for any loss sustained by him by reason of his having purchased or procured any materials, or entered into any engagements or made any advances on account of or with a view to, the execution of the work or the performance of the contract. And in case the contract shall be rescinded under the provision aforesaid, the contractor shall not be entitled to recover or be paid any sum for any work thereto for actually performed under this contract, unless and until the Superintending Engineer shall

have certified in writing the performance of such work and the value payable in- respect thereof and he shall only be entitled to be paid the value so certified.

- (iv) Security deposit of contractor for each work will be refunded only **one year** after the date of completion of work provided the final bill has been paid and defects if any rectified.

**Clause-3**

In any case in which any of the powers, conferred upon the Superintending Engineer by clause 3 thereof, shall become exercisable and the same shall not be exercised the non exercise thereof shall not constitute a waiver of the conditions here of and such powers shall notwithstanding be exercisable in the event of any failure cases if defaults by the contractor of which by any clause or clauses thereof he is declared liable to pay compensation amounting to the whole of his security deposit, and

**Contractor remain liable to pay compensation if action not taken under clause-3**

the liability of the contractor for past and future compensation shall remain unaffected in the event of the Superintending Engineer putting in force the powers vested in him under the preceding clause he may if he so desire, take possession of all or any tools, plants, materials & stores, in or upon the works or the site thereof or belonging to the contractor or procured by him and intended to be used for the execution of the work or any part thereof paying or all wing for the same in the account at the contract, rates, or in case of these not being applicable ; at current

market rates to be certified by the Executing Engineer whose certificate thereof shall be final; otherwise the Superintending Engineer may give notice in writing to the contractor or his clerk of the works, foreman or

other authorized agent required him to remove such tools, plants, materials or stores from the premises (within a time to be specified in such notice) and in

**Power to take possession of or require removal of or sell contractor plants**

the event of the contractor failing to comply with any requisition to the Superintending Engineer may remove them at the contractor's expense or sell them by auction or private sale on account of the contractor and at his risk in all respects and the certificate of the Superintending Engineer as to the expense of removal and the amount of proceeds and expense of any such sale shall be final and conclusive against the contractor.

**Clause – 4**

If the contractor shall desire on extension of time for completion of the work, on the ground of his having been unavoidable hindrances in its execution or any other ground he shall apply in writing to the

**Extension of time**

Superintending Engineer within 30 days of the date of the hindrance on account of which he desires such extension as aforesaid and the Superintending Engineer shall, if in his opinion (which shall be final) reasonable be shown therefore, authorize such extension of time if any, as may in his opinion, be necessary or proper. The Superintending Engineer shall at the same time inform the contractor whether he claims compensation for delay.

**Clause – 5** On completion of the work, the contractor shall be furnished with a certificate by the Superintending Engineer (here-in-after called the Engineer-in-charge) of such completion, but no such certificate be given, nor shall the work be considered to be complete until the contractor shall have removed from the area of premises (to be distinctly marked by the Superintending Engineer in the site plan) on which the work shall be executed, all scaffolding surplus materials and rubbish and cleaned off the dirt from all wood work doors, windows, walls,

floors or other parts of any building in upon or about which the work is to be executed, or of which he may

**Final Certificate**

have had possession for the purpose of the execution thereof nor until the work shall have been measured by the officer of the PWD in accordance with the rules of the department whose measurements shall be binding and conclusive against the contractor the contractor shall fail to comply with the requirements of this clause as removal of scaffolding surplus materials and rubbish and cleaning of dirt on or before the date fixed for the completion of the work the Engineer-in-charge may at the expenses of the contractor, remove such scaffolding surplus materials and rubbish and dispose of the same as he thinks fit and clean off such dirt as aforesaid and the contractor shall forth with pay the amount of all expenses incurred and shall have no claim in respect of any such scaffolding, or surplus materials as aforesaid except for any sum actually realized by the sale thereof

**Sub clause – 5** “If in the opinion of the Engineer-in-charge which shall be final and binding on the contractor occupation or utilization of a portion of the work completed in no way interferes with the progress for rest of the work, the same may be occupied or utilized by or on behalf of the Govt. under the written order of the Engineer-in-charge to get the defects of any rectified by the contractor at his (Contractor) own cost within six months from the date of completion of the whole work provided that the contractor will not be allowed any other concession either in the shape of extensions of stipulated period or any other monetary compensation on account of such occupation or use.

**Clause – 6** A bill shall be submitted by the contractor each month on or before the date fixed by the Engineer-in-charge for all works executed in the previous month, and the Engineer-in-charge or his

**Payment on intermediate certificate be regarded as advance & bill to be submitted monthly**

subordinate shall take the requisite measurement for the purpose of having the

same verified and the claim as far as admissible' adjusted if possible before the expiry of ten day from the presentation of the bill. If the contractor does not submit the bill within the time fixed as aforesaid, the Engineer-in-charge or his subordinate shall measure up the said work in the presence of the contractor whose countersignature to the measurement list will be sufficient warrant and the Engineer-in-charge or his subordinate shall prepare a bill from such list which shall be binding on the contractor in all respects.

Provided that, if any balance of the 7% security is outstanding from each such payment shall be deducted so much, not exceeding 5% as may be necessary to make up the balance of the security. All such intermediate payments shall be regarded as payment by way of advance against the final payment only and not as payments for work actually done and completed and shall not preclude the requiring of bad, unsound and imperfect or unskillful work to be removed and taken away and requiring or re-erected, or be considered as an admission of the due performance of the contract, or any part thereof in any respect, or the actual of any claim nor shall it conclude, determine or effect in any way the powers of the Engineer-in-charge under these conditions or any of them as the final settlement or adjustment of the accounts or otherwise, or in any other way vary or effect the contract.

**Clause – 7** The final bill shall be prepared by the officers of the P.W.D. in accordance with the rules of department in the presence of the contractor within one month of the date fixed for completion of the work.

**Clause – 8 DELETED**

**Clause - 9** The contractor shall execute the whole and every part of the work in the most substantial and workman like manner and both as regards materials and otherwise in every respect in strict accordance with

the specification. The contractor shall also confirm exactly fully and faithful to the design, drawings & instructions in writing relating to the work signed by

**Works to be executed in accordance with specification drawing & orders etc.**

the Engineer-in-charge and lodged in his office and to which the contractor shall be entitled to have access at such office for the purpose of inspection during office hours and the contractor shall, if he so require be entitle at his ownexpense to make or cause to make copies of the specifications and of all such designs, drawings and instructions as aforesaid.

**Sub clause – 9** The work should be done strictly in accordance with the relevant specifications of the I.S.I. Codes. If the work is not covered by the specification of I.S.I. it should be done in accordance with the provision in the Odisha Detailed Standard Specifications (O.D.S.S). In case, the work is not covered by O.D.S.S. the work should be executed as per the instruction of the Engineer-in-charge.

**Clause – 10** The Engineer-in-charge shall have power to make any alterations in or additions to the original specifications, drawing, designs and instruction that may appear to him to be necessary advisable during the progress of the work and

**Alteration in specification and designs**

the contractor shall be bound to carry out the work in accordance with any instruction which may be given to him in writing signed by

the Engineer-in-charge and such alteration shall not invalidate the contract and any additional work which the contractor may be directed to do in the manner above specified as part of the work shall be carried out by the

**Extension of time in consequence of alterations**

contractor on the same conditions in all respect on which he agreed to do the main work, and at the same time rates as are specified in

the tender for the main work., The time for the completion of the work shall be extended in the proportion that the additional work includes bears to the original contract work

**Do not invalidate contract**

and the certificate of the Engineer-in-charge shall be conclusive as to such proportions. And if the additional work includes any class of work for which no rate is specified in this contract then such class of work shall be carried out at the rates entered in the sanctioned schedule of rates of the locality during the period when the work being carried on and if such last mentioned class of work is not entered on the scheduled of rate of the district then the contractor shall within seven days of the date of his receipt of the order to carry out the work inform the Engineer-in-charge of the rate which is it his intention to charge for such class of work, and if the Engineer-in-charge does not agree to this rate he shall by notice in writing be at liberty to cancel his order to carry out such class of work and arrange to carry it out in such manner as he may consider advisable.

No deviations from the specification stipulated in the contract or additional items of work shall ordinarily be carried out by contractor nor shall any altered. Additional or substituted work to be carried out by him unless the rates on the substituted altered of additional items have been approved and fixed in writing by the Engineer-in-charge.

**Rates of works not in estimate of schedule or rate of the district.**

The contractor shall be bound to submit his claim for any additional work done during any month on or before the 5<sup>th</sup> days of the following month accompanied by copy of the order in writing of the Engineer-in-charge for the additional work and that the contractor shall not be entitled to any payment in respect of such additional work if he fails to submit his claim within the aforesaid period.

Provided always that if the contractor shall commence work incur any expenditure in regards thereof before the rates shall have been determined as lastly herein before mentioned, then and in such case he shall only be entitled to be paid in respect of the work carried out or expenditure incurred by him prior to the date of determination of the rates as aforesaid according to such rates as shall be fixed by the Engineer-in-charge. In the event of dispute the decision of the Superintending Engineer of the circle will be final.

**Clause – 11** If at any time after the commencement of the work the

Government of Odisha shall for any reason whatsoever not require the whole thereof as specified in the tender to be carried out the Engineer-in-charge

**No compensation for alteration in or restriction of work to be carried out.**

shall give notice in writing of the fact to contractor. Who shall have no claim to any payment or compensation whatsoever on account of any profit or advantage, which he might have derived from the execution of the work in full but which he did not derive in consequence of the full amount of the work not having been carried out, neither shall he have any claim for compensation by reason of any alternations having been made in the original specification, drawing, designs and instruction which shall involve any curtailment of the work as originally contemplated.

**Clause – 12** If it shall appear to the Engineer-in-charge or his subordinate in charge of the work that

any work has been executed with unsound, imperfect or unskillful workmanship or with materials of any inferior description, or that any materials or articles provided by him for execution of the work are unsound

**Action and compensations payable in case of bad work.**

or of a quality inferior to that contracted for or other wise not in accordance with the contract, the contractor shall on demand in writing from the Engineer-in-charge specifying the work materials or articles complained of not with standing that the same may have been inadvertently passed, certified and paid for forth with rectify or remove and reconstruct the work so specified in whole or part, as the case may require or as the case may be remove the materials or articles so specified and provided other proper and suitable materials or articles at his own proper charge and cost and in the event of his failing to do so within a period to be specified by the Engineer-in-charge in his demand aforesaid then the contractor shall be liable to pay compensation at the rate of one percent on the amount of the estimate for every day not exceeding ten days while his failure to do so shall continue and in the case of any such failure the Engineer-in-charge may rectify or remove and re-execute the work or remove and replace with other

the materials or articles complained of as the case may be at the risk and the expense in all respects of the contractor.

**Clause – 13** All work under or in course of execution or executed in pursuance of the contract shall at all times be open to the inspections and supervision of the Engineer-in-charge and his subordinates and the contractor shall at all times during the usual working hours, and at all other times at which reasonable notice of intention of Engineer-in-charge or his subordinates to visit the works shall have been given to the contractor either himself be present to receive orders and instructions, or have a responsible agent duly accredited in writing present for that purpose, Orders given to the contractor’s agent shall be considered to have the same force as if they had been given to the contractor himself.

**Works to be open to inspection**

**Contractor or responsible agents to be present**

**Clause – 14** The contractor shall give not less than five day’s notice in writing to the Engineer- in-charge or his subordinate in-charge of the work before covering up or other wise placing beyond the reach of measurement of any work in order that the same may be measured and correct dimensions thereof be taken before the same is so covered up or placed beyond the reach of measurement and shall not cover up or placed beyond the reach of measurement any work without the consent in writing of the Engineer-in-charge or his subordinate in charge of work and if any work shall be cover up or placed beyond the reach of measurement without such notice having been given or consent obtained, the same shall be uncovered at the contractor’s expense, or in default thereof no payments or allowance shall be made for such work or the materials with which the same was executed.

**Notice to be given before work is covered up**

**Clause – 15** If the contractor or his work people or servants shall break, deface, injure or destroy any part of a work, in which they may be working or any building, road, enclosure or grass land, or cultivated ground continuous to the premises on which work or any part of it being executed, or if any damage shall happen to the work while in progress from any cause whatever or any imperfection become apparent in it within six Months from the date of final certificate of its completion shall have been given by the Engineer-in-charge, as aforesaid the contractor shall make the same good at his own expense, or in default the Engineer-in-charge may cause the same to be made good by other workmen, and deduct the expense( of which the certificate of

**Contractor liable for damage done and for imperfections for 6 months after certificate**

the Engineer-in-charge shall be final) from any sums that may be then or at any time thereafter may become due to the contractor, or from his security deposit or the proceeds of sale thereof, or of a sufficient portion thereof and the contractor shall be liable to pay any part of the expenses not so recovered by the Engineer- in-charge.

**Clause – 16** The contractor shall supply at his own cost all materials (except such special materials if any as may in accordance with the contract be supplied from the Engineer-in-charge’s stores) plant, tools, appliances, implements, ladders, cordage, tackle scaffolding and temporary works requisite or proper for the proper execution of the work whether original altered or substituted and whether included in the specification or other documents forming Part of the contract or referred to in these conditions or not or which may be necessary for the purpose of satisfying or complying with the requirement of the Engineer-in-charge as to any matter as to which under this conditions he is entitled to be satisfied which he is entitled to require together with carriage therefore to and from the work. The contractor shall also supply without charge the requisite number of persons with the means and materials necessary for the purpose of setting outwork and counting, weighing and assisting in the measurement of examination at any time and from time to time the work or materials, failing him so doing the same may be provided by the Engineer-in-charge at the expenses of the contractor and the expenses may be deducted from any money due to the contractor under the contract or from his security deposit or the proceeds of sale thereof, or of a sufficient portion thereof. The contractor shall also provide all necessary fencing and lights required to protect the public from accident and shall be bound to bear the expenses of defence to every suit, action or other proceeding at law that may be brought by any persons for injury sustained owing to neglect of the above precautions, and to pay any damages and cost which may be awarded in any such suit action or proceeding to any such person or which may with the consent of the contractor be paid to compromise any claim by any such person.

**Contractor to supply plants, ladders, scaffolding etc.**

**And is liable for damages arising from non provision of lights, fencing etc.**

**Clause – 17** No female labour shall be employed within the limits of a cantonment. The contractor shall not employ for the purpose of this contract any labour below the age of twelve year, and shall pay to each labourer; for the work done by such labour, wages not less than the wage paid for similar work in the neighborhood.

**Explanation :** Fair wages means wages whether for time or piece work prescribed by State P.W.D. provided that where higher rates have been prescribed under the minimum wages Act 1948 wages at such higher rates would constitute “Fair wages” [W/D No.22059 dated 16.8.77.

The Superintending Engineer shall have the right to enquire into and decide any complaints alleging that the wages paid by the contractor to any labourer for the work done by such labourer is less than the wages paid for similar work in the neighborhood.

The officer in charge of the work shall have the right to decide whether labourer employed by the contractor is below the age of twelve years and to refuse to allow any labourer whom he decides to be below the age of twelve years to be employed by the contractor.

**Clause – 17 (a)** The contractor shall, if so required by the Engineer-in-charge employ one more Engineering Graduate or Diploma holder as apprentices at his own cost if the cost of work as shown in the tender exceeds Rs.2,50,000/- The apprentices will be selected by the Chief Engineer. The period of employment will commence within one month after the date of work order and would last till the date when 90% of work is completed. The stipend to be paid to the apprentices, should not be less than Rs.200/- per day in case of graduate Engineers and not less than Rs.150/- per day in case of Diploma holders. The number of apprentices to be employed should be fixed by the Chief Engineer in a manner so that total expenditure does not exceed 1% of the tender cost of the work.

**Clause – 17 (b)** Special class Contractor shall employ under him one Graduate Engineer and Two Diploma Holders belonging to the State of Odisha. Like wise ‘A’ class contractor shall employ under him one Graduate Engineer or

Two Diploma holders under the contractor shall be full time & continuous and they should not be superannuated, retired, dismissed or removed personnel from any State Govt. or Central Govt.

**Employment of  
Graduate  
Engineers &  
Diploma Holders**

service/public Sector undertakings, private companies and firms or be ineligible for appointment to Government service. The contractor shall pay them monthly

emoluments which shall not be less than the emoluments of the personnel of equivalent qualification employed under the State Government of Odisha. The Chief Engineer, Roads Odisha may however, assist the contractor with names of such unemployed Graduate Engineer and Diploma holders if such help is sought

for by the contractor. The names of such Engineering personnel appointed by the contractor should be intimated to the tender receiving authority along with the tender. Each bill of the Special Class or 'A' class contractor shall be accompanied by an employment Roll of the Engineering personnel together with a certificate of the Graduate Engineer or Diploma holder is employed by the contractor to the effect that the work executed as per the bill has been supervised by him.

**Clause – 18**

The contract shall not be assigned or sublet without the written approval of the Superintending Engineer and if the contractor shall assign or sublet his contract or attempt so to do, or become insolvent or commence any insolvency proceedings or make any composition with his creditor or attempt so to do, or if any bribe gratuity, gift loan, perquisite reward or advantage pecuniary of other wise shall either directly or indirectly be given, promised or offered by the contractor or any of his servants to agents to any public officer or person in the employee of Government in any way relating to his office of

**Work not to be sublet.**

employment or if any such officer or person shall become in any way directly or indirectly in the contract, the Superintending Engineer may thereupon by notice inwriting rescind the contract and the security deposit of the contractor shall there upon stand forfeited and be absolutely at disposal of Government and the same consequences shall ensure as if the contract has been rescinded under clause 3 hereof and in addition the contractor, shall not be entitled to recover or be paid for any work therefore actually performed under the contract.

**Contractor may be rescinded and security deposit forfeited subletting bribing or if contractor become in solvent**

**Clause – 19**

All sums payable by way of compensation under any of these conditions shall be considered as reasonable compensation to be applied to the use of Government without reference to the actual

**Sum payable by way of compensation to be considered as reasonable compensation with out reference to actual loss**

loss or damage sustained, and whether or not any damage shall have been sustained.

**Clause – 20**

In the case of a tender by partners any changes in the constitution of the firm shall be forthwith notified by the contractor to the Engineer-in-charge for his information.

In case of failure to notify the change in the constitution within fifteen days the Engineer-in-charge may be noticed in writing rescind the contract and the

**Changes in constitution of firm**

security deposit of the contractor shall there upon stand forfeited and be

absolutely at the disposal of Government and the same consequences shall ensure as if the contract had been rescind under clause 3 hereof and in addition the contractor shall not be entitled to recover or be paid for any works therefore actually performed under the contract.

**Clause – 21** All works to be executed under the contract shall be executed under the direction and subject to the approval in all respects by Superintending Engineer of the circle for the time being who shall be entitled to direct at what point or points and in what manner they are to be commenced, and from time to time carried on.

**Clause – 22** **DELETED**

**Clause – 23** When the estimate on which a tender is made includes lump sums in respect of the items of work involved or the part of the work the contractor shall be entitled to payment in respect of the item of work involved or the part of the work in question at the same rates as are payable under this contract for such items, or if the part of the work in question is not, in the opinion of the Engineer-in-charge capable of measurement, the Engineer-in-charge may by his discretion pay the lump sum amounts entered in the estimate, and the certificate in writing of the Engineer-in-charge shall be final and conclusive against the contractor with regard to any sums payable to him under the provisions of this clause.

**Lump sums in estimates**

**Clause – 24** In the case of any class of work for which there is no such specification as is mentioned in rule, such work shall be carried out in accordance with the circle specification and in the event of there being no circle specification, then in such case the work shall be carried out in all respects in accordance with the instructions and requirements of the Engineer-in-charge.

**Action where no specification**

**Clause – 25** The expression ‘work’ or ‘works’ where used in these conditions shall unless there be something either in the subject or context repugnant to such construction be construed & taken to mean the works by or by virtue of contract contracted to be executed whether temporary or permanent, and whether original altered, substituted, or additional.

**Definition of works**

**Clause – 26** Government shall be entitled to recover in full from the contractor any amount that the Government may be liable to pay under workmen compensation Act. VIII of 1923, to any workmen employed in course of execution of any part of the work covered by this contract.

**Clause – 27** That for the purpose of jurisdiction in the event of dispute if any, the contract should be deemed to have been entered into within the State of Odisha and it is agreed that neither party to the contract or agreement will be competent to bring

a suit in regard to the matters covered by this contract at any place outside the State of Odisha.

**Clause – 28** The Department will have the right to inspect the scaffolding and centering made for the work and can reject partly or fully such structure if found defective in their opinion.

**Clause – 29** Sanitary arrangement will be made by the contractor at his own cost for his labour camp.

**Clause – 30** The contractor shall bear all taxes including sales tax, income tax, royalty, fair weather charges and tollage, where necessary.

## **Clause-31: Price Adjustment**

: Contract price shall be adjusted for increase or decrease in rates and price of labour, materials, fuels and lubricants in accordance with the following principles and procedures and as per formula given in following Paras.

(a) The price adjustment shall apply for the work done from the start date given in the contract data up to end of the initial intended completion date of extensions granted by the Engineer and shall not apply to the work carried out beyond the stipulated time for reasons attributable to the contractor.

(b) The price adjustment shall be determined during each month from the formula given in following Paras.

(c) Following expressions and meanings are assigned to the work done during each month :

R= Total value of work done during the month. It would include the amount of secured advance granted, it any, during the month, less the amount of secured advance recovered, it any during the month. It will exclude value for works executed for extra items under variations.

: To the extent that full compensation for any rise or fall in costs to the contractor is not covered by the provisions of this or other clauses in the contract, the unit rates and prices included in the contract shall be deemed to including amounts to cover the contingency of such other rise or fall in costs :

The formula (e) for adjustment of prices are :

### **31(a) (i) : Adjustment of Other Materials Component**

Price adjustment for increase or decrease in cost of local materials other than cement, steel, bitumen, pipe and POL procured by the contractor shall be paid in accordance with the following formula :

$$V_M = 0.85 \times P_m/100 \times R \times (M_1 - M_0)/M_0$$

$V_M$  = Increase or decrease in the cost of work during the month under consideration due to changes in rates for local materials other than cement, steel, bitumen and POL.

$M_0$  = The all India wholesale price index (all commodities) on 28 days preceding the date of opening of Bids, as published by the Ministry of Commerce and Industry, Government of India, New Delhi.

$M_1$  = The all India wholesale price index (all commodities) for the month under consideration as published by the Ministry of Commerce and Industry, Government of India, NewDelhi.

$P_m$  = Percentage of local material component (other than cement, steel, bitumen and POL) of the work.

### **31(a) (ii) : Adjustment for Cement Component**

Price adjustment for increase or decrease in cost of cement procured by the contractor shall be paid in accordance with the following formula :

$$V_C = 0.85 \times P_C / 100 \times R \times (C_1 - C_0) / C_0$$

$V_C$  = Increase or decrease in the cost of work during the month under consideration due to changes in rates for cement.

$C_0$  = The all India wholesale price index for Ordinary Portland Cement (OPC) on 28 days proceeding the date of opening of Bids as published by the Ministry of Commerce and Industry, Government of India, New Delhi.

$C_1$  = The all India wholesale price index for Ordinary Portland Cement (OPC) for the month under consideration as published by the Ministry of Commerce and Industry, Government of India, New Delhi.

$P_C$  = Percentage of Cement Component of the work.

### **31(a) (iii) : Adjustment for Steel Component**

Price adjustment for increase or decrease in cost of steel procured by the contractor shall be paid in accordance with the following formula :

$$V_S = 0.85 \times P_S / 100 \times R \times (S_1 - S_0) / S_0$$

$V_S$  = Increase or decrease in the cost of work during the month under consideration due to changes in rates for steel.

$S_0$  = The all India wholesale price index for steel (Mild Steel long products) on 28 days proceeding the date of opening of Bids as published by the Ministry of Commerce and Industry, Government of India, New Delhi.

$S_1$  = The all India wholesale price index for steel (Mild Steel long products) for the month under consideration as published by the Ministry of Commerce and Industry, Government of India, New Delhi.

$P_S$  = Percentage of steel component of the work.

**Note : For the application of this clause, index of (Mild Steel long products) has been chosen to represent steel group.**

### **31(a) (iv) : Adjustment of Bitumen Component**

Price adjustment for increase or decrease in cost of bitumen shall be paid in accordance with the following formula :

$$V_b = 0.85 \times P_b / 100 \times R \times (B_1 - B_0) / B_0$$

$V_b$  = Increase or decrease in the cost of work during the month under consideration due to changes in rate for bitumen.

$B_0$  = The official retail price of bulk bitumen at the IOC / BPCL depot at nearest center on the day 28 days prior to date of opening of Bids.

$B_1$  = The official retail price of bulk bitumen at the IOC / BPCL depot at nearest center for the 15<sup>th</sup> day of the month under consideration.

$P_b$  = Percentage of bitumen component of the work.

### **31(a) (v) : Adjustment towards differential cost of pipes**

Price adjustment for increase or decrease in cost of pipe shall be paid in accordance with the following formula :

$$V_{pi} = 0.85 \times P_{pi}/100 \times R \times (P_{i1}-P_{i0})/P_{i0}$$

$V_{pi}$  = Differential cost of pipe i.e. amount of increase or decrease in rupees to be paid or recovered during the month under consideration.

$P_{pi}$  = Percentage of pipe component of the work.

$P_{i1}$  = All India wholesale price index of pipe for the period under consideration as published by the Ministry of Commerce and Industry, Government of India, New Delhi.

$P_{i0}$  = The all India wholesale price index of pipe on 28 days preceding the date of opening of Bids as published by the Ministry of Commerce and Industry, Government of India, New Delhi.

### **31(b) : Adjustment of Labour Component**

Price adjustment for increase or decrease in cost due to labour shall be paid in accordance with the following formula :

$$V_L = 0.85 \times P_l/100 \times R \times (L_1-L_0)/L_0$$

$V_L$  = Increase or decrease in the cost of work during the month under consideration due to changes in rates for local labour.

$L_0$  = The minimum wages for unskilled labour as Notified by Government of Odisha as prevailed on the last stipulated date of receipt of tender including extension, if any.

$L_1$  = The minimum wages for unskilled labour as Notified by Government of Odisha as prevailed on the last date of the month previous to the one under consideration.

$P_l$  = Percentage of labour component of the work.

### **31(c) : Adjustment of POL (fuel and lubricant) Component**

Price adjustment for increase or decrease in cost of POL (fuel and lubricant) shall be paid in accordance with the following formula :

$$V_f = 0.85 \times P_f/100 \times R \times (F_1-F_0)/F_0$$

$V_f$  = Increase or decrease in the cost of work during the month under consideration due to changes in rates for fuel and lubricants.

$F_0$  = The official retail price of High Speed Diesel (HSD) at the existing consumer pumps of IOC / BPCL / HPCL at nearest center on the day 28 days prior to the date of opening of Bids.

$F_1$  = The official retail price of HSD at the existing consumer pumps of IOC / BPCL / HPCL at nearest center for the 15<sup>th</sup> day of the month under consideration.

$P_f$  = Percentage of fuel and lubricants component of the work.

**Note : For the application of this clause, the price of High Speed Diesel oil has been chosen to represent fuel and lubricants group.**

## **31(d) : Adjustment for Plant and Machinery Spares Component**

Price adjustment for increase or decrease in cost of plant and machinery spares procured by the Contractor shall be paid in accordance with the following formula :

$$V_p = 0.85 \times P_p / 100 \times R \times (P_1 - P_0) / P_0$$

$V_p$  = Increase or decrease in the cost of work during the month under consideration due to changes in rates for plant and machinery spares.

$P_0$  = The all India wholesale price index for manufacture of machinery for mining, quarrying and construction on 28 days preceding the date of opening of Bids as published by the Ministry of Commerce and Industry, Government of India, New Delhi.

$P_1$  = The all India wholesale price index for manufacture of machinery for mining, quarrying and construction for the month under consideration as published by the Ministry of Commerce and Industry, Government of India, New Delhi.

$P_p$  = Percentage of plant and machinery spares component of the work.

**Note : For the application of this clause, index of manufacturing of machinery for mining, quarrying and construction has been chosen to represent the plant and machinery spares group.**

Regarding wholesale price index (WPI) for appropriate commodity for payment of price adjustment, due to change of base year of WPI from 1993-94 to 2004-05 & 2011-12, it is observed that, the commodity 'Bars and Rod', 'Cement', 'Heavy machinery and parts' included in the list of WPI 1993-94 series are not mentioned as such in the WPI 2004-05 & 2011-12 series. Therefore, the following items in the WPI 2004-05 & 2011-12 series shall be considered corresponding to items in WPI 1993-94 series :

Sl. No.	Item in WPI 1993-94 series	Item in WPI 2004-05 series	Item in WPI 2011-12 series
1.	Cement	Grey Cement	Ordinary Portland Cement
2.	Bars & Rods	Rebars	Mild steel long products
3.	Heavy Machinery & parts	Construction Machinery	Manufacture of machinery for mining, quarrying & construction

## **31(e) : APPLICATION OF ESCALATION CLAUSE :**

The contractor shall for the purpose of availing reimbursement / refund of differential cost of steel, bitumen, cement, pipe, POL and wages, keep such books of account and other documents as are necessary to show that the amount of increase claimed or reduction available and shall allow inspection of the same by a duly authorized representative of Government and further, shall at the request of the Engineer-in-Charge, furnish documents to be verified in such a manner as the Engineer-in-Charge may require any document and information kept. The contractor shall within a reasonable time of 15 days of his becoming aware of any alternation in the price of such material, wages of labour and / or price of POL give notice thereof to the Engineer-in-Charge stating that the same is given pursuant to this condition along with information relating to there to which he may be in position to supply.

### **Percentage Table**

Sl. No.	Category of Works		% Component (cost wise)		
			Labour (P <sub>l</sub> )	POL (P <sub>f</sub> )	Steel (P <sub>s</sub> ) + Cement (P <sub>c</sub> ) + Bitumen (P <sub>b</sub> ) + Pipes (P <sub>pi</sub> ) + Plant & Machinery Spare & Component (P <sub>p</sub> ) + Other Materials*
1.	R & B works (% of component)	Road Works	5	5	90
		Bridge Works	5	5	90
		Building Works	5	5	90
2.	Irrigation works (% of component)	Structural Work	5	5	90
		Earth, Canal & Embankment work	5	5	90
3.	P.H. Work	Structural Work	5	5	90
		Pipeline Work	5	5	<u>Pipe - 70%</u> * Machinery + Other material-20%
		Sewer Line	5	5	<u>Pipe - 70%</u> * Machinery + Other material-20%

\*Note :- Further break up may be worked out considering the consumption of Cement, Steel, Bitumen, Pipe and Plant & Machinery Spare Component in the concerned works and shall be provided in the bid document in shape of **“Schedule of Adjustment Data”** as an **“Appendix to Bid”** (enclosed herewith).

## **Appendix to Bid Schedule of Adjustment Data**

[For all works, adjustment factor for Labour and POL shall be considered at the rate 5% each. Steel, Cement, Pipes, Other Materials and Machinery shall contribute to 90% of Price Adjustment and shall be calculated for each work separately during preparation of estimate, shall be approved by the authority during technical sanction as a **“Schedule of Adjustment Data”** and shall form part of the Bid Document. The cases where the original technically sanctioned estimate gets revised, the technical sanction to the revised estimate will be obtained from the competent authority as provided under Para 3.11.2 (b) of OPWD Code, Volume-I. Based on the revised technically sanctioned estimate, the Labour & the POL component shall be given the weightage of 5% each as provided in O.M. No.15847/W dated 19.11.2019 of Works Department and the weightage of 90% on steel, cement, bitumen, pipes, other materials and plant and machinery spare component shall be given as per the technically sanctioned revised estimate excluding the extra items. The revised weightage of **“Schedule of Adjustment Data”** based on revised technically sanctioned estimate shall be included as an **Addendum** to the agreement. The technical sanctioning authority shall be the competent authority for this purpose.].

Cl. No.31 of F2/P1 Contracts Sl. No.	Index Description	Source of Index	Base Value*	Base Date*	Weightage of Item**
31 (a) (i)	Other Materials	All India wholesale price index (all commodities) as published by the Economic Advisor to the Govt. of India, Ministry of Commerce and Industry.			48.07%
31 (a) (ii)	Cement	Wholesale price index for Cement (Ordinary Portland Cement) as published by the office of the Economic Advisor to the Govt. of India, Ministry of Commerce and Industry.			1.21%
31 (a) (iii)	Steel	Wholesale price index for steel (Mild Steel-Long Products) as published by the office of the Economic Advisor to the Govt. of India, Ministry of Commerce and Industry.			0%
31 (a) (iv)	Bitumen (VG-30)	The official retail price of bulk bitumen at the nearest IOC / HPCL depot.			26.12%
31 (a) (v)	Pipes	Whole sale price index for the type of Pipe under consideration, as published by the office of the Economic Advisor to the Govt. of India, Ministry of Commerce and Industry.			0%
31 (b)	Labour	Minimum Wage notified by the Labour and Employee's State Insurance Department of Government of Odisha, India.			5.0%
31 (c)	POL	Official retail price of HSD at nearest IOCL / HPCL / BPCL Consumer Pump Depot.			5.0%
31 (d)	Plant and Machinery	Wholesale price index for manufacture of machinery for mining, quarrying and construction as published by the office of the Economic Advisor to the Govt. of India, Ministry of Commerce and Industry.			14.60%
			Total		100.00%

\* Values to be filled up at the time of drawal of contract.

\*\* Values to be filled up in the bid document.

**Clause – 32** After the work is finished all surplus material and debris are to be removed by the contractor and preliminary works such as vats, mixing platforms etc. are to be dismantled and all materials removed from site. The ground up to 100m wide from the building should be cleared and dressed.

## **FAIR WAGE CLAUSE**

**Clause – 33(a)**The contractor shall pay not less than fair wage to labourers engaged by him on the work.

Explanation: “Fair wages” means wages, whether for time or piece work prescribed by the State Public works Department provided that where higher rates have been prescribed under the Minimum Wages Act. 1948 wages at such higher rates would constitute “Fair wages” (W.D. No.22059 dt.16.8.77)

- (b) The contractor shall, notwithstanding the provisions of any contract to contrary cause to be paid a fair wage to labourers indirectly engaged on the work including any labour engaged by his sub contractors in connection with the said work, as if the labours had been immediately employed by him.
- (c) In respect of all labour directly or indirectly employed in the works for the performance of the contractor’s part of this agreement, the contractor shall comply with or cause to be complied with all regulation made by Government in regard to payment of wages, wage period deductions from wages, recovery of wages not paid and deductions unauthorisedly made, maintenance of wages register, wage cards, publication of scale of wages and other terms of employment, inspection and submission of periodical returns and all other matters of a like nature.
- (d) The Superintending Engineer or Sub-Divisional Officer concerned shall have the right to deduct, from the money due to contractor, any sum required or estimated to be required for making good the loss suffered by a worker or workers by reason of non fulfillment of the conditions of the contract for the benefit of workers non payment of wages or of deductions made from his or their wages, which are not justified by their terms of the contract” or non-observance of the regulations, money so deducted should be transferred to the workers concerned.
- (e) Vis-à-vis the Government of Odisha, the contractor shall be primarily liable for all payments to be made under and for the observance of the regulations aforesaid without prejudice to his right to claim indemnity from his sub contractor.
- (f) The regulations aforesaid shall be deemed to be part of this contract and any breach there of shall be breach of this contract.
- (g) The contractor shall at his own expense provide or arrange for the provision of foot wear for any labour doing cement mixing work and black topping of roads (The contractor has undertaken to execute under this contract) to the satisfaction of the Engineer-in-charge and on his failure to do so Government shall be entitled to provide the same and recover the cost from the contractor.
- (h) The contractor shall submit by the 4<sup>th</sup> & 10<sup>th</sup> of every month, to the Engineer-in-charge a true statement showing in respect of the Second half of the preceding month and the first half to the current month respectively (1) the number of labours employed by him on the work (2) their working hours (3) the wages paid to them (4) the accident that occurred during the said fortnight showing the circumstances under which they happened and the content of damage and injure caused by them and (5) the number of female workers who have been allowed maternity benefit according the clause [K] and the amount paid to the Government a sum not exceeding **Rs.472.00** for each default of materially incorrect statement. The amount levied as fine decision of the Superintending Engineer shall be final in deducting from any bill due to contractor.

- (i) In respect of all labour directly employed in the works for the performance of the contractor's part of this agreement, the contractor shall comply with a cause to be complied with all the rules framed by Government from time to time for the protection of health and sanitary arrangement for workers employed by the Odisha Public Works Department and its contractor. This will apply to work places having 50 or more workers.
- (j) Maternity benefit rules for female worker employed by contractor, Leave and pay during leave shall be regulated as follows.

1- Leave : (i) **In case of Delivery:-** Maternity leave not exceeding 8 weeks, 4 weeks up to including the day of delivery or 4<sup>th</sup> weeks following that day.

(ii) **In case of Mis carriage :-** Up to 3 weeks from the date of miscarriage.

2. Pay (i) **In case of Delivery:-** Leave pay during maternity leave will be at the rate of women's average daily earnings calculated on the total wages earned on the days when full time work was done during a period of three months immediately preceding the date of which she gives notice that she expects to be confined or at the rate of **Rs.472.00** a day which ever is greater.

(ii) **In case of Miscarriage :** Leave pay at the rate of average daily earnings calculated on the total wages earned on the days when full time work was done during a period 3 months immediately preceding the date of such miscarriage,

Conditions of grant of Maternity Leave: No maternity leave benefit shall be admissible to a women unless she has been employed for a total period not less than 6 months immediately preceding the date on which she proceeds on leave.

**Clause 34** Incentive should be paid in respect of individual project for new construction / substantial additional or improvement works, the minimum value of which is mentioned below.

<u>Name of Work</u>	<u>Minimum Value</u>
1. Building work / PH work	Rs.40.00 lakhs
2. Road work	Rs.3.00 crores
3. Irrigation work	Rs.10.00 crores

Incentive will be paid with approval of next higher authority of tender accepting authority on completion of original work before original time schedule. Incentive need not be included in the estimate. Specific budget provision may be made under State Plan out of which the incentive shall be met.

For availing incentive clause in any project which is completed before the stipulated date of completion, subject to other stipulations it is mandatory on the part of the concerned Superintending Engineer to report the actual date of completion of the project as soon as possible through fax or e-mail so that the report is received within 7 (seven) days of such completion by the concerned SE, CE & the Administrative Department. The incentive for timely completion should be on a graduated scale of 1 (one) percent to 5 (five) percent of the contract value. Assessment of incentives may be works out for earlier completion of work in all respect in the following scale.

Before 30% of contract period	=	5% of Contract value
Before 20 to 30% of contract period	=	4% of Contract value
Before 10 to 20% of contract period	=	3% of Contract value
Before 5 to 10% of contract period	=	2% of Contract value
Before 5% of contract period	=	1% of Contract value

**Clause 35** The royalty of materials will be recovered from the work bill in case failure of production of proper receipt from quarry holder or Revenue Department after proper verification from concerned Tahasildar.

**MODEL RULES FOR HEALTH & SANITARY  
ARRANGEMENTS FOR WORKERSEMPLOYED BY  
ODISHA P.W.D. OR IT'S CONTRACTORS**

1. **Application :** These rules shall apply to all construction work in charge of Odisha Public Works Department which are expected to continue for a year or more.

2. **Definitions :**

- (i) "Work Place" means a place at which an average of fifty or more workers are employed in connection with construction work
- (ii) Large work place means a place at which an average of 500 or more workers are employed in connection with construction work.

3. **First Aid :**

- (a) At every work place there shall be maintained in a readily accessible place first aid appliances including and adequate supply of sterilizer dressing and sterilized cotton wool. The appliances shall be kept in good order and in large work places they shall be readily available during working hours.
- (b) At large work places where hospital facilities are not available within easy distance of the workers, first aid posts shall be established and run by a trained compounder.
- (c) Where large work places are remote from regular hospitals an indoor ward shall be provided with one bed for every 250 employees.
- (d) Where large work places are situated in cities towns or in their suburbs and no beds are considered necessary owing to the proximity of city, town hospitals, an ambulance shall be provided to facilitate removal of urgent cases to these hospitals. At the work place some conveyance facilities such as a car shall be kept readily available to take injured persons or person to the nearest hospitals.

4. **Drinking Water :**

- (a) In every work places, there shall be provided and maintained at suitable places, easily accessible to labour, a sufficient supply of water fit for drinking.
- (b) Where drinking water is obtained from an intermittent public water supply each work place shall be provided with storage where such drinking water shall be stored.
- (c) Every water supply of storage shall be at a distance of not less than 50 feet from any latrine, drain or other sources of pollution where water to be drawn from an existing well which is within such proximity of latrine drain or any other sources of pollution the well shall be properly chlorinated before water is drawn from it for drinking. All such wells shall be

entirely closed in and be provided with tray door which shall be dust and water proof.

- (d) A reliable pump shall be fitted to each covered well the tray door shall be kept locked and opened only for cleaning or inspection which shall be done at least once a month.
- (e) The temperature of drinking water supplied to workers shall not exceed 90° F.

**5. Washing and Bathing Place :**

- (i) Adequate washing and bathing places shall be provided separately for men and women.
- (ii) Such places shall be kept in clean and drained condition

**6. Scale of Accommodation in Latrines and Urinals :-** There shall be provided within the premises of every work place latrines and urinals in an accessible place; and the accommodation, separately for each of them shall not be less than the following.

- (a) Where the number of persons employed does not exceed 50. No. of seats 1
- (b) Where the number of persons employed exceeds 50 but does not exceed 100 No. of Seats 3
- (c) For every additional 100 No. of seats 3 per 100(in  
particulars cases the Superintending Engineer shall  
have the power to vary the scale where necessary)

**7. Latrine and Urinals for Women :** If women are employees, separate latrines and urinals separate from that for women and marked in the vernacular in conspicuous letter “for women only” shall be provided on the scale laid in rule.

Those for men shall be similarly marked “ for men only” A poster showing the figure of a men and women and shall also be exhibited at the entrance of Latrines for each sex. There shall be adequate supply of water close to the urinals and latrines.

**8. Latrines and Urinals :** Except in work places provided with water flushed latrines connected with a water borne sewerage system, all latrines shall be provided with receiptable on dry- earthen system which shall be cleaned at least four times daily and at least twice during working hours and kept in a strictly sanitary condition. The receiptables shall be tarred inside and out side at least once a year.

**9. Construction of Latrines :** The inside wall shall be constructed of masonry or stone materials and shall be cement washed inside and outside at least once a year. The dates of cement washing shall be noted in register maintained for this purpose, and kept available for inspection.

**10. Disposal of excreta :** Unless otherwise arranged for by the local sanitary authorities arrangements for proper disposal of excreta by incineration at the work place shall be made by means of a suitable incinerator approved by as, Director of Public Health of Municipal Medical Officer or Health at the case may be, whose jurisdiction the work place is situated. Alternatively excreta may be disposed off by putting a laver of night soil at the bottom of pucca tank prepared for the purpose and covering it with 6’ layer of waste or refuse and than covering it up with a layer of earth for a fortnight (when it will

- turn in to manure).
11. **Provision of shelters during rest :** At every work place, there shall be provided free of cost two suitable sheds one for females and the other for rest for the use of labourers. The height of the shelter shall be less than 11 feet from the floor level the lowest part of the roof.
  12. **Creche :** At every work place at which more than 50 women workers are employed, there shall be provided only one hut for the use of children under the age of 6 year , belonging to such women and shall be used for infant’s games and play and their bed room. The huts shall not be constructed on a lower standard than the following.
    - i) Thatched huts
    - ii) Mud floors and walls.
    - iii) Planks spared over the mud floor and covered with matting.

The hut shall be provided with suitable and sufficient openings for light and ventilation. There shall be adequate provision for sweepers to keep the place clean. There shall be two dhai in attendance. Sanitary utensil shall be provided to the satisfaction of the Health Officer of the area concerned. The use of the hut shall be restricted to Children, their attendants and mothers of the children.

    - a) Where the number of women workers is more than 50 the contractor shall provide one hut and Dhai to look after the Children of women workers.
    - b) The size of creche shall vary according to the number of women workers.
    - c) The crèche shall be properly maintained and necessary equipments like toys etc. Shall be provided.
  13. **Canteen :** A cooked food canteen :- on a moderate scale shall be provided for the benefit of workers whenever it is considered expedient.
  - 14.

## CONTRACTOR’S LABOUR REGULATIONS

1. **Short title :-** These regulation may be called “ The Odisha Public Works Department / Electricity Department Contractor’s Regulations”.
2. **Definition :** In these Regulations, unless otherwise expressed or indicated the following words and expressing shall have the meaning hereby assigned to them respectively, that is say:
  - (a) “Labour” means workers employed by a contractor “**Improvement to Right Service Bank Road of Sapua Link Channel from RD 2.100 Km to RD 5.330 Km of Sapua Badjore Irrigation Project.**” directly or indirectly through a sub-contractor or other person, by an agent on his behalf.
  - (b) Fair wages means wages whether for time or piece work prescribed by the **Superintending Engineer, Angul Irrigation Division, Angul** provided that where high rates have been prescribed under the minimum wages Act 1948 wages at such higher rates would constitute fair wages (W.D. No.22059 dt,16.8.77)
  - (c) “Contractor” shall include every person whether a sub-contractor or headman or agent employing labour on the work taken on contract.

- (d) "Wages" shall have the same meaning as defined in the payment of wages Act. And include time and piece rate wages if any.

### **3. Display of notices regarding ways, etc.:-**

The contractor shall:-

- (a) Before he commences his work on contract display, and correctly maintain and continue to display and correctly maintain, in a clean and legible condition in a conspicuous places on the work, notice in English and in the local Indian language spoken by the majority of the workers giving the rate of wage prescribed by State Public Works Department/ **Angul Irrigation Division,Angul** for the district in which the work is done.
- (b) Send a copy of such notices to Engineer-in-charge of the work.

## **4. Payment of Wages :-**

- (a) Wages due to every worker shall be paid to him direct.
- (b) All wage shall have to be paid in cash in current coin or currency or in both.

## **5. Fixation of wages periods :-**

- (a) The contractor shall fix the wage period in respect of which the wages be payable.
- (b) No wage period shall exceed one month.
- (c) Wage of every workman employed on the contract shall be paid before the expiry of ten days, after the last day of the wage period in respect of which the wages are payable.
- (d) When the employment of any worker is terminated by or on behalf of the contractor the wages earned by him shall be paid before the expiry of the day succeeding the one on which his employment is terminated.
- (e) All payment of wages shall be made on a working days

## **6. Wage book and wage cards etc.**

- 1) The contractor shall maintain a wage book of each worker in such forms as may be convenient, but the same shall include the following particulars:-
- a) Rate of daily or monthly wages.
- b) Nature of work on which employed.
- c) Total number of days worked during each wage period.
- d) Total amount payable for the work during each wage period.
- e) All deductions made from the wages with an indication in each of the ground for which the deduction is made.
- f) Wage actually paid for each wage period.
- 2) The contractor shall also maintain a wage card for each worker employed on the work.

- 3) The Superintending Engineer may grant an exemption from the maintenance of wage bond, wages cards to a contractor who, in his opinion may not directly or indirectly employ more than 100 persons on the work.

## **7. Fines and deduction, which may be made from wages.**

- 1) The wages of a worker shall be paid to him without any deductions of any kind except the following.
  - a) Fines.
  - b) Deduction for absence from duty, i.e. from the place or places where by terms of his employment he is required to work. The amount of deductions shall be in proportion to the period for which he was absent.
  - c) Deduction for damage to or loss of goods expressly entrusted to the employed person for custody' or for loss on money for which he is required to encount where such damage or loss is directly attributable to his neglect or default.
  - d) Any other deduction which the Odisha Government may from time to time allow.
- 2) No fines shall be imposed on a worker and no deduction for damage or loss shall be made from his wages until the worker has been given an opportunity of showing abuse against such fines or deduction.
- 3) The total amount of fines which may be imposed in any one wage period on a works shall not exceed a amount equal to Five paise in a rupee of the wages payable to him in respect of that wage period.
- 4) No fine imposed on any worker shall be recovered from him by installments after the expiry of 60 days from the date on which it was imposed.

## **8. Register of fines, etc.**

- 1) The contractor shall maintain a register of fines and of all deduction for damage or loss. Such register shall mention the reason for which fine was imposed or deduction for damage or loss was made.
- 2) The contractor shall maintain a list in English and in the local Indian language clearly defining acts and omissions for which penalty of fine can be imposed. It shall display such list and maintain it in a clean and legible condition in conspicuous place on the work.

## **9. Preservation of register:**

The wage register, the wage cards and the register of fines, deduction required to be maintained under these regulations shall be preserved for 12 months after date of the last entry made in them.

## **10 Powers of Labour Welfare Officers to make investigation or enquiry**

The labour Welfare Officers or any other persons authorized by the Government of Odisha on their behalf shall have power to make enquiries with a view to ascertaining and enforcing due and proper observance of the fair wage clauses and the provision of these regulations. He shall investigate into any complaint regarding default made by the contractor, sub contractor in regard to such provisions.

## **11. Report of Labour Welfare Officers:**

The Labour Welfare Officers or others authorized as aforesaid shall submit a report of the results of his investigation of enquiry to the Superintending Engineer concerned indicating the extent, if any, to which the default has been committed with a note that necessary deductions from the contractor's bill be made and the wages and other dues be paid to the labourers concerned.

## **12. Appeal against the decision of Labour Welfare Officers.**

Any persons aggrieved by the decision and recommendation of the Labour Welfare Officer or other person so authorized may appeal against such decision to the Labour Commissioner within 30 days from the date of decision forwarding simultaneously a copy of this appeal to the Superintending Engineer concerned but subject to such appeal, the decision of the officer shall be final and binding upon the contractor.

## **13. Inspection of registers:**

The contractor shall allow inspection of wage book, card to any of his worker or his agent at a convenient time and place after due notice is received, or to the Labour Commissioner or any other person authorized by the Government of Odisha on his behalf.

## **14. Submission of return:**

The contractor shall submit periodical returns as may be specified from time to time.

## **15. Amendment**

The Government of Odisha may from, time to time add to or amend these regulations and on any question as to the application interpretation of effect of the regulations the decision of the Labour Commissioner or any other persons authorized by the Government of Odisha in that behalf shall be final.

### **Clause - 36 Departmental supply of materials**

Before issue of Departmental materials to the contractor, he shall furnish Bank Guarantee of any of the Nationalized Bank equal to the cost of materials. The Bank Guarantee shall be valid for the entire period of agreement. The same may be refunded to the contractor only after the materials supplied to him are fully utilized in the works and cost thereof recovered from his bill (s) in full or if the materials are partly utilized in the unutilized materials are returned by him to the Department in full and in good condition and receipt thereof duly acknowledged by the concerned Department Officer.

(Works Department OM No. Codes-M-19/92-13653 dt. 5.6.93)

**Clause - 37** The terms and conditions of the agreements have been read/ explained to me and certify that I/We clearly understand them.

**1. ADDENDUM TO CONDITION OF CONTRACT:**

The bidder / Tender whose bid has been accepted will be notified of the award by the Engineer-in-Charge prior to expiration of the validity period by cable, telex or facsimile confirmed by registered letter. This letter (hereinafter and in the conditions of contract called the (“Letter of Acceptance”) will state the sum that the Engineer-in-Charge will pay the contractor in consideration of the execution, completion and maintenance of the works by the contractor as prescribed by the contract (hereinafter and in the contract called the “Contract Price”).

The notification of award will constitute the formation of the contract, subject only to the furnishing of a performance security (ISD) and additional performance security in accordance with the provisions of the agreement.

The agreement will incorporate all agreements between the officer inviting the bid/Engineer-in-Charge and the successful bidder. Within 15 days following the notification of award alongwith the letter of acceptance, the successful bidder will sign the agreement and deliver it to the Engineer-in-Charge. Following documents shall form part of the agreement.

- a) The notice inviting bid, all the documents including additional conditions specifications and drawing, if any, forming the bid as issued at the time of invitation of bid and acceptance thereof together with any correspondence leading thereto & required amount of performance security including additional performance security.
- b) Standard P.W.D. Form P1.

## 2. TIME CONTROL

Progress of work and Re-scheduling programme

The Superintending Engineer / Engineer-in-Charge shall issue the letter of acceptance to the successful contractor. The issue of the letter of acceptance shall be treated as closure of the bid process and commencement of the contract.

Within 15 days of issue of the letter of acceptance, the contractor shall submit to the Engineer-in-Charge for approval and programme commensurate to clause no 3 showing the general methods, arrangements, and timing for all the activities in the works along with monthly cash flow forecast.

To ensure good progress during the execution of the work the contractors shall be bound in all cases in which the time allowed for any work exceeds one month to complete, 1/4<sup>th</sup> of the whole of the work before 1/4<sup>th</sup> of the whole time allowed under the contract has elapsed, 1/2 of the whole of the work before 1/2 of the whole time allowed under the contract has elapsed, 3/4<sup>th</sup> of the whole of the work before 3/4<sup>th</sup> of the whole time allowed under the contract has elapsed.

If at any time it should appear to the Engineer-in-Charge that the actual progress of the works does not conform to the programme to which consent has been given, the contractor shall produce, at the request of to such programme necessary to ensure completion of the works within the time for completion. If the contractor does not submit an updated programme within this period, the Engineer-in-Charge may withhold the amount of 1% of the contract value from the next payment certificate and continue to withhold this amount until the next payment after the date on which the over due programme has been submitted.

An update of the programme shall be a programme showing the actual progress achieved on each activity and the effect of the progress achieved on the timing of the remaining work including any changes to the sequence of the activities.

The Engineer-in-Charge's approval of the programme shall not alter the contractor's obligations. The contractor may revise the programme and submit it to the Engineer-in-Charge again at any time. A revised programme is to show the effect of variations and compensation events.

Extension of the completion date.

The time allowed for execution of the work as specified in the contract data shall be the essence of the contract. The execution of the works shall commence from the 15<sup>th</sup> Day or such time period as mentioned in letter of award after the date on which the Engineer-in-Charge issues written orders to commence the work or from the date of handing over of the site whichever is later. If the contractor commits default in commencing the execution of the work as aforesaid, Government shall without prejudice to any other right or remedy available in

law, be at liberty to forfeit the earnest money and performance guarantee / security deposit absolutely.

As soon as possible after the contract is concluded the contractor shall submit a Time & Progress Chart for each milestone and get it approved by the Department. The Chart shall be prepared in direct relation to the time stated in the Contract documents for completion of items of the works, it shall indicate the forecast of the dates of commencement and completion of various trades of sections of the work and may be amended as necessary by agreement between the Engineer-in-Charge and the Contractor within the limitations of time imposed in the contract documents and further to ensure good progress during the execution of the work, the contractor shall in all cases in which the time allowed for any work, exceeds one month (save for special jobs for which a separate programme has been agreed upon) complete the work as per milestone given in contract data.

Incase of delay occurred due to any of the reasons mentioned below, the contractor shall immediately give notice thereof in writing to the Engineer-in-Charge but shall nevertheless use constantly his best endeavors to prevent or make good the delay and shall do all that may be reasonably required to the satisfaction of the Engineer-in-Charge to proceed with the works.

For

- i. Abnormally bad weather, or
- ii. Serious loss or damage by fire, or
- iii. Civil commotion, local commotion of workmen, strike or lockout, by officers any of the heads employed on the work, or
- iv. Delay on the part of other contractors or trademen engaged by Engineer-in-Chief, in executing work not forming part of the contract.
- v. Incase of variation is issued which makes it impossible for completion to be achieved by the Intended Completion Data without the Contractor taking steps to accelerates the remaining work and which would cause the contractor to incur additional cost, or.
- vi. Any other cause, which in the absolute discretion of the authority mentioned, in contract data is beyond the contractor's control.

Request for re-schedule and extension of time, to be eligible for consideration shall be made by the contractor in writing fourteen days of the happening of the event causing delay. The Contractor may also, if practicable, indicate in such a request the period for which extension is desired.

In any such case a fair and reasonable extension of time for completion of work may be given. Such extension shall be communicated to the Contractor by the Engineer-in-Charge in writing. Within 3 months of the date of receipt of such request, Non-application by the contractor for extension of time shall not be a bar for giving a fair and reasonable extension by the Engineer-in-Charge and this shall be binding on the contractor.

## **Compensation for delay.**

If the contractor fails to maintain the required progress in terms of clause 2 or to complete the work and clear the site on or before the contract or extended date of completion he shall without prejudice to any other right or remedy available under the law to the Government on account of such breach, pay as agreed compensation the amount calculated at the rates stipulated below as the Superintending Engineer (whose decision in writing shall be final and binding) may decide on the amount of tendered value of the work for every completed day/month (as applicable) that the progress remains below that specified in Clauses 2 or that the work remains incomplete.

This will also apply to items or group of items for which a separate period completion has been specified Compensation @ 1.5% per month or for delay of work, delay to be computed on per day basis.

The existing relevant provision in the original documents shall stand modified accordingly. Provided always that the total amount of compensation for delay to be paid under this condition shall not exceed 10% of the Tendered Value of work or to the Tendered Value of the item or group of items of work for which separate period of completion is originally given. The amount of compensation may be adjusted or set-off against any sum payable to the Contractor under this or any other contract with the Government. In case the contractor does not achieve a particular milestone mentioned in contract data, or the rescheduled milestone

(s) in items of Clause 2.5. the amount shown against that milestone shall be withheld, to be adjusted against the compensation levied at the final grant of extension of time. Withholding of this amount on failure to achieve a milestone, shall be automatic without any notice the contract. However, if the Contractor catches up with the progress of work on the subsequent milestone(s), the withheld amount shall be released. In case the contractor fails to make up for the delay in subsequent milestone(s) amount mentioned against each milestone missed subsequently also shall be withheld. However, no interest whatsoever, shall be payable on such withheld amount.

### **Management Meetings**

Either the Engineer or the Contractor may require the other to attend a management meeting.

The business of a management meeting shall be review the plans for remaining work and to deal with matters raised in accordance with the early warning procedure.

- i. The Engineer shall record the business of management meetings and to provide copies of his record to those attending the meeting and to the Employer. The responsibility of the parties for actions to be taken is to be decided by the Engineer either the management meeting or after the management meeting and stated in writing to all who attended the meeting.

**Signature of witness**

**signature of contractor**

## **Grant of EOT and imposing penalty in EOT / Deviation:-**

As per the letter no. 699, dated. 07.01.2021 of DoWR, Odisha, following decision has been taken regarding grant of EOT and imposing penalty in EOT / Deviation.

(i) **Basis of imposing of penalty in EOT/Deviation.**

1. In case of completion of the work in all respect, the EOT may be granted with imposition of penalty amounting to 0.2% (amount to be rounded off to the next higher value of Rs.100/-) of the value of works executed during the extended period (EOT period), subject to minimum penalty of Rs10,000/-.
2. In case of incomplete works /to rescind the contract, the contract to be closed as per the provision contained in Clause-2(b) of F2 agreement, 20% of the value of left-over work will be realised from the Contractor as penalty.

The suggestions / recommendations of the CE/CCE with respect to imposition of penalty is to be examined by the Technical Committee of EIC, W.R and considered views may be forwarded to Government for necessary action.

(ii) Reason of hindrances for sanction of EOT attributable to the agency/not attributable to the agency)

- Reasons of hindrances for sanction of EOT attributable to the agency.

1. The local festivals like Makar Sankranti, Raja Sankranti, Chaiti Parba, Danda Nata or any such festivals which may affect the work schedule.
2. In the peak summer season, working hour is curtailed by the Labour Department to avoid exposure to personnel to the scorching sun and heat. It is the duty of the agency to increase the number of work force and to employ the existing work force during morning and afternoon hours as per Government orders.
3. Rainfall is a normal occurrence during monsoon in Odisha. So, unless there is unusually heavy rainfall resulting in a declared calamity, the Contractor is not eligible for any extension of time. The Contractor should plan the deployment of workforce and machinery, so as to complete the work as per schedule considering ordinary vagaries of the nature.
4. The same applies for borrow areas ponding. The Contractor should foresee possible ponding of borrow area in monsoon and likewise lift more quantity of soil/ other material during dry period so as to complete the work as per schedule.
5. The Contractor should take up the work with due diligence in the acquired land without waiting for acquisition of the entire land. This should be completed in proportionally less period depending on the quantum of available work front.
6. The Agency should plan his work programme and mobilize men and machineries considering the canal closure programme of a particular system or area. Khariff / Rabi closure can't be imposed arbitrarily on the farmers as per the convenience of the agency. Closure of canal for the interest of work will be solely at the discretion of the Engineer-in-charge and can't be claimed as a matter of right.
7. There will always be standing crop before harvesting season as per crop schedule and this fact has to be clearly understood by the agency. Extension of time on this ground may not be considered by Divisional Officers.

- Reasons of hindrances for sanction of EOT not attributable to the agency.

1. Only the day(s) of elections to the Local Bodies/Assembly/Parliament will be treated as a non-working day(s)
2. Unless there is unusually heavy rainfall resulting in a declared calamity, the Contractor is not eligible for any extension of time.
3. Force majeure.
4. Abnormally bad weather, cyclones etc.
5. Civil commotion, local commotion of workmen, strike or lockout, affecting any of the trades employed on the work.
6. Delay on the part of other contractors engaged by the Engineer-in-charge in executing work not forming part of the contract.
7. In case a variation/additional work is issued which makes it impossible for completion to be achieved by the intended Completion Date without the contractor taking steps to accelerate the remaining work and which cause the contractor to incur additional cost.
8. Any other cause, which in the absolute discretion of the authority mentioned, contract data is beyond the contractor's control.

(iii) Application for EOT as per Codal provision (Para 3.5.30 of OPWD Code)

The application for Extension of Time for completion of the work on the grounds of unavoidable hindrance or any other grounds shall be positively submitted by the contractor within 30 days of such hindrance. This should be strictly followed.

**SECTION-6**

**TECHNICAL SPECIFICATION**

## TECHNICAL SPECIFICATION

### CHAPTER – 1

#### 1.0 GENERAL INFORMATION

1.1 The work under specification pertain “**Improvement to Right Service Bank Road of Sapua Link Channel from RD 2.100 Km to RD 5.330 Km of Sapua Badjore Irrigation Project**” The information and data relating to work and site conditions described hereafter represents the site condition in a general way. It shall be presumed that the contractor satisfies himself as to nature and location of work in general, land, local conditions particularly on the power and handling, storage of materials, disposal of soil, foundation data and bore hole data and etc., before arriving at his rate. The department therefore will not bear any responsibility for any inference on the site condition and consequence thereof.

#### 1.2 Availability of labour:

Labour required for the work may be available to some extent at the project area. The contractor must, however, make his own arrangements to fulfill his requirement.

#### 1.3 Towns

**Rasol is a developed town with Bus facilities is about 7 kms (avg) distance from working site.**

#### 1.4 Access to site:

The site is accessible by all weather existing roads.

The department shall not be liable for compensation due to hindrance caused by the regular pedestrian traffic, and in the event of breakdown in communication for closure of the roads due to repairs or for any reason. It is the responsibility of the contractor to make all arrangement for development and maintenance of haul road and approach road as per his requirement as and when required.

#### 1.5 Availability of Diesel and Lubricants :

Pumps for supply of diesel, petrol and other lubricants are located at **Rasol**.

#### 1.6 Electric Power for construction purpose:

The Contractor himself is to arrange for requirement of power for the work.

The contractor shall enter agreement with Tata Power Central Odisha Distribution Limited (TPWODL) for taking electricity consumption and payment as per requirement of the contractor.

The electrical energy consumed by the contractor shall be measured by suitable metering arrangement to be installed by the contractor on approval of TPWODL at the point of supply. The meter will be sealed in presence of the contractor or his authorized agent and readings will be taken every month for finding the electricity consumed.

### **Tariff Rate:**

The tariff rate for consumption of electricity will be in accordance with Electricity (supply) Act, 1948 and Tata Power Central Odisha Distribution Limited (General Conditions of Supply) Regulations as amended from time to time.

### **Observance of Rules**

The distribution of power to the contractor's colony, equipments etc. from the one point supply will be done by the contractor at his own cost.

The contractor shall observe all the conditions required under rule 45 (i) of Indian Electricity Rules (1956) and other pertinent rules for carrying out the electrical installation works in his premises. Power supply to the installations not satisfying the Indian Electricity Act and Rules is liable to be cut off and the department will not have any responsibility for any losses and damages caused for the above.

The contractor shall take all precautions to ensure safety of the workers engaged in his electrical lines and installations. The department will not have any responsibility for any accident that may occur in contractor's installation.

In case of break-down in power supply for any reason what-so-ever the department is not liable for compensation.

The contractor shall take action to rectify the defects, if any, in the installations when pointed out by the Engineer-in-charge or TPCODL in a reasonable time.

The Contractor shall permit the department to draw power required for the departmental works, if any from the contractor's L.T. lines as and when required by the department. The department will pay the contractor for such consumption at the prevailing tariff rate of TPCODL.

### **Housing**

Private houses may not be available at project site but available at **Rasol**.

Land for the construction of temporary houses for the labour may be arranged by the agency at his own costs.

### **Medical Aid**

There is a Government Hospital at **Rasol** which provides free treatment. The contractor shall however make at his own cost first-aid arrangements at the various work sites in accordance with the labour rules and regulations and as directed by the Engineer-in-charge.

### **Post, Telegraph & Telephones**

Postal and Telegraphic facilities are available at **Rasol**. Telephone connections are also available at **Rasol** and the same can be availed by the contractor at his own cost.

### **Local Roads**

The existing approach roads to the site of work to the extent available shown in the map enclosed can be used by the contractor. The contractor shall, however construct and maintain connecting roads within the working areas and in his Labour colony areas at his cost. The contractor shall construct and maintain haul roads and other approach roads etc., as may be necessary for the proper execution of the work.

### **Dump Areas.**

Materials excavated from the foundations and in connection with other items of work shall be dumped as directed by the engineer-in-charge from time to time. The contractor shall construct and maintain all roads to the working areas for excavation of foundations, laying of concrete etc., at his own expense.

### **Other Contractors.**

In the matter of dumps, haul roads, diversions, excavations for the foundations etc., the contractor shall take into consideration the needs and requirements of other contractors, if any, working in the vicinity. There should be proper and adequate co-ordination between the working in the vicinity. Further the contractor shall not make or cause discontent or disturbance to the work, labour or arrangements etc. of other contractors in the neighboring and the project localities.

### **Use of Site.**

Contractors will be permitted to use without any charge the site and all lands under the control of project organization as required for execution of work. The Contractor shall not commence any operation on such lands except with the prior approval of the Engineer-in-charge.

All areas of operations including those for his staff and labour colonies handed over to the contractor shall be cleared and handed over to the Engineer-in-charge after completion/recession of contract. While handing over, the contractor shall make good to the satisfaction of the Engineer-In-charge any damage or alteration made to areas or to other property or land handed over to him for purpose of these work.

Temporary structures may be erected by the contractor for storage sheds, office, residence etc., for non commercial use on the land handed over to him at his expenses and with the permission of the Engineer-in-charge. At the completion of the work, these structures should be dismantled and the site cleared and handed over to the department. The lands required for providing amenities in connection with the work will be given free of cost from the Government lands as shown in the plan enclosed.

### **Floods**

In case of flash and untimely floods in the river/nalla during the working season resulting in

over-topping of coffer dam and flooding of the work area, the contractor shall make his own arrangements at his cost to shift the machineries, equipments, materials, labour and departmental machineries if hired by the contractor to a safe place. The work shall have to be resumed after receding of floods and necessary strengthening of coffer dam and dewatering will be done by the contractor at his cost. Extension of time for the completion of the procurement processes may be considered by the employer if the discontinuance of the work is beyond the all reasonable attempts of the contractor to thwart such eventualities.

The silt, debris, sand and other materials accumulated in the working area during flash floods or regular floods in the monsoon shall be removed by the contractor as required for continuing the work at his own cost. By any chance, if any excavated portion that could not be filled with concrete by the contractor gets filled up during the monsoon period with earth and silt, its removal will not be paid for again. The contractor will have to re-excavate the same at his own cost.

It shall be distinctly understood that it is entirely the responsibility of the contractor to make such arrangements as may be required from time to time to protect the men, machinery, materials and the work under progress and work for which the measurements were recorded and payment made, against damages either during working season or during the flood season the department accepts no liability, what-so-ever for any damage or loss of men, materials, machinery and work of hindrance caused to the progress of work except as provided in specific clause of General Conditions of Contract under contractor's risk and insurance.

The contractor should provide at his own cost adequate protection measures to the completed works at the end of working season or work in progress against the probable flood during monsoon till completion and handing over of entire work.

## **CHAPTER – II**

### **2. GENERAL SPECIFICATION**

The enclosed drawing in the bid document gives broad dimensions and outline of the works to be executed through this contract. These drawings may however be revised / modified from time to time and supplementary additional drawing may also be issued as per necessity. During the course of execution there may be changes in dimension, specifications and shape of components. The changes in the drawing can be done without any way deviating the terms of the contract and the contractor is to execute the work as per revised drawings and specifications at the same rate as agreed upon for the work awarded under the original contract. The contractor shall do no work without proper drawings. He shall check all drawings and specifications carefully and advise the Engineer-In-charge, if any error and omission are discovered where upon the Superintending Engineer will prepare revised additional drawings and specifications as may be required to suit the state of the work. Where the drawings are not consistent with the text of the specification, the text shall govern.

The rates quoted shall be for finished items of work as per description in schedule of quantities and according to drawings, specifications and conditions of the contract. Detailed construction drawings shall be furnished by the Department. Rates quoted shall be for items of works, specifications of which confirm to details furnished in this report and provisions in Bureau of Indian Standards and shall include all general and incidental charges which will not be paid separately. Such general and incidental charges are listed below for the convenience of the tenderers but are not exhaustive. Omission of any such items herein but required for delivering finished items of work, shall not be a plea that such items are not covered by the rates quoted.

Formation and maintenance of haul roads within the work site, (i) are to be done by the contractor at his own cost. (ii) Existing approaches and haul roads, if any, under the control of the barrage organization may be made use of, but improvement, if required, shall be at contractor's cost.

Labour & material required for construction of reference points, bench marks, pillars etc. for setting out the works shall be at contractor's cost.

The rate offered includes cost of all leads, lifts and scaffolding and gang-ways as and when required for the work. No additional payment in this regard will be entertained.

**Construction** of coffer dam, dewatering of any water that may accumulate in the working areas as required for carrying out the items under schedules of quantities. This shall include the initial dewatering of the pond formed after the formation of coffer dam and all seepage that may accumulate in the area before construction has to be carried out.

Removal of temporary protection arrangements for the reinforcements and instrument pipes left projecting from the unfinished constructed sections to be attended to in the next working season. The reinforcement etc. have to be thoroughly cleaned and straightened before these are embedded in concrete/masonry.

Providing protection arrangements as per drawing for the reinforcement rods and instrumentation pipes, cable etc., during flood season intervening any two working seasons.

Protection works for the piers during the flood season intervening any two working seasons. This is however, indicative of the actual protection works that will depend on the location and the point of protection and should be done to the satisfaction of the Engineer-in-charge. The responsibility for the safety of the structure rest entirely on the contractor and any damage that occur have to be made good by him at his cost.

Green cutting/high pressure water jetting /chipping off old concrete surface, over which fresh concrete is to be laid, so as to remove laitance and expose coarse aggregate.

Cleaning the areas that will be covered by concrete thoroughly with air and water jet just before laying concrete and applying slurry of cement mortar 1:2.

From work complete including cost of materials, labour, maintenance, erection and removal.

Providing blocks outs (for second stage embedded metal parts of gates) with reinforcement

projecting into the block outs.

Fixing first stage embedded metal parts in the block outs.

Furnishing samples of welds to the department for testing cost of binding wire, tack welding wherever required and arrangement for movement of labourers for pouring concrete over the reinforcement such that the sag does not exceed 12 mm.

The sequence of construction to be adopted by the contractor shall have to be approved by the Chief Engineer. Normally sequence of construction shall be from a lower level to a higher level and from one end of the barrage to other or from both ends or from one end of the service road to other end.

#### **Coffer Dam and its Maintenance.( Applicable if necessary )**

The contractor has to make his own design for the coffer dam and furnish the same along with this tender. The cofferdam may be designed for 25 years return flood for non monsoon flows. Any material required for the coffer dam shall be arranged by the contractor. The design of the coffer dam shall be such that its section is of erodible nature and should not form an obstruction to river flow during monsoon period. The design should receive the prior approval of the Engineer-in-charge before being actually executed by the contractor. Forming the necessary coffer dam and its maintenance for the work contemplated in all the working seasons till the final completion date, shall be the responsibility of the contractor. However flash and untimely floods cannot be ruled out during the working season for which the coffer dam should be suitably constructed and maintained by the contractor at his own cost.

#### **Equivalency of Standard and Codes.**

Whenever reference is made in the Contract to specific standards and codes to be met by the goods and materials to be furnished, and work performed or tested, the provisions of the latest current edition or revision of the relevant standards and codes in effect shall apply, unless otherwise expressly stated in the Contract. Where such standards and codes are national, or relate to a particular country or region other authoritative standards which ensure an equal or higher quality than the standards and codes specified will be accepted subject to the Engineer's prior review and written approval. Differences between the standards specified and the proposed alternative standards must be fully described in writing by the Contractor and submitted to the Engineer at least 28 days prior to the date when the Contractor desires the Engineer's approval. In the event the Engineer determines that such proposed deviations do not ensure equal or higher quality, the Contractor shall comply with the standards specified in the document.

#### **Quality Control**

Before collecting materials required for execution of the respective items of work and laid down in the schedule of quantities and in the detailed specifications described hereafter in the subsequent sections, the contractor shall ensure that samples of materials proposed to be

used are first approved by the Engineer-in-charge. When directed the samples of materials proposed to be used should be furnished to the **Departmental Quality Assurance Division , Samal** for testing.

All such testing charges shall be borne by the contractor. The contractor will provide necessary assistance if required for collection of samples. The contractor is liable to pay for any test which is not included in the Agreement but required in the opinion of the Engineer-in-charge during execution of the work for which no additional payment will be made to the contractor.

On the basis of satisfactory test results confirming to technical specification, collection of materials shall be started from the quarry. The testing of materials shall be checked in the field laboratory by the Department as well as staff of Quality Assurance organization. If the field test result is found unsatisfactory, the materials shall be rejected.

On receipt of notice from the Engineer-In-Charge and on observation of **Quality Assurance Division , Samal** the contractor will rectify the defects in stipulate period at his own cost, If the defects are not rectified in the stipulated period, the Engineer-in-charge shall assess the cost, get the defect rectified and recover the same from the dues of the Contractor.

A quarry chart indicating possible sources of materials may be seen in the office of the **Superintending Engineer, Angul Irrigation Division, Angul**.The contractor must however satisfy himself that the materials as required as per specifications and quantity are available in those quarries. No extra payment will be made due to non-available in those quarries. No extra payment will be made due to non-availabilitymaterials as per required specification and quantity in the quarries shown in the departmental quarry chart. The quarry chart is only an indication of source of materials and the department does not accept the responsibility if the materials are not available in full quantity and quality.

No claim for carriages of water whatsoever will be entertained .

Decision regarding usefulness of excavated materials rests fully on the Engineer-In- Charge.

## CHAPTER- III EARTH WORK

### **Scope of work : This section covers item**

#### **Description of the Item:**

Refer item No.

of Bill of Quantity.

#### **Excavation Foundation.**

##### **Excavation.**

The item includes excavation of foundation for the work which include the R.C.C., Cutoff, raft,abutments, piers, wing walls, cement concrete blocks and loose stone aprons etc. The foundation

levels to which the excavation will be made are indicated in the relevant drawings. If the excavation is required to be taken to levels other than those indicated in the drawings the payment on such excavation shall be governed by the same rates in which bidding has been done in the tender schedule. The item "Excavation" as herein used shall in general include excavation after the formation of cofferdam and dewatering of the area, transportation of the excavated material to the dumped area or as directed by the Engineer-in-charge throughout the period of working. During the stage of excavation where stone or concrete blocks are encountered requiring removal by chiseling or blasting, the same shall be done with precaution as specified. The area shall be first excavated up to 15cm. above the foundation level as shown in the drawing. The balance excavation has to be completed only in a few hours before placing concrete. Arrangements for placing concrete shall be made only after the area is inspected and approved by Engineer-in-charge.

##### **Disposal of Materials**

Before excavation is started, the deposition of spoil should be carefully planned. The excavated material shall be dumped sufficiently clear of the edges of excavation permitting ample space for installing and lifting of dewatering machines, stacking construction materials etc. or transported to coffer dam, afflux bunds, guide bunds, back filling of abutments or to stock pile areas. In forming stock piles, the useful materials shall be stocked in separate areas with reference to the nature of the materials. Excavated materials, if found suitable, should be utilized for filling behind abutments, and in the afflux bund and guide bund, for which no extra payment will be made. Steps should be taken to keep the materials; clean as subsequent cleaning will be difficult and imperfect. All other excavated materials shall be dumped in permanent spoil banks or other approved locations. Spoil

banks shall be located where they will not interfere with the natural flow of the river or will not obstruct any drainage arrangement.

##### **Measurement.**

Immediately prior to the beginning of the work, accurate cross sections of existing ground level at suitable intervals or closer where necessary and normal to the axis/alignment shall be taken over the area to be excavated. Final sections along the same line after the removal of each class of excavation and also on the completion of the excavation shall also be taken. Volumes will then be computed for materials excavated under the different classifications and will be paid for at the rates of respective items which also include conveyance

of excavated materials Including loading, unloading and stacking as directed by the Engineer-in-charge.

### **Dewatering**

The Contractor has to make his own arrangement for dewatering from the working area at his own cost and the unit rates for each item of work quoted by the contractor shall include the cost of dewatering and river diversion and cofferdam.

### **Excavation in all kinds of Hard Rock & Disposal.**

Normal methods of excavation will be by use of explosive i.e by blasting methods, however excavation by wedging, barring and chiseling and control blasting can be done as required at site as per direction of the Engineer-in-charge. The contractor's Item / percentage rates shall include all necessary operations such as ordinary methods of blasting, wedging, barring, chiseling and controlled blasting etc. including loading and transportation to the places away from the project site in low and areas in a systematic manner as directed by Engineer-in-charge. Normal methods of excavation will be by blasting with explosive, all operations, involving transportation, handling, storage, and use of explosives for the blasting shall be confirmed in accordance with the Indian explosives Act. The contractor shall engage licensed blasters for taking up the blasting operations in the work spot. The contractor shall take all necessary precautions for all accidents which may arise due to blasting. The contractor should have portable magazines near the work site for carrying out day to day blasting operations.

### **Line Drilling and Broaching**

Excavation in rock shall be progressed by systematic line drilling and broaching or by chiseling in locations specified by the Engineer-in-charge.

### **Blasting**

Blasting shall be permitted only when proper pre calculation are taken for the protection of persons, work and property & on receipt of permission from civil authorities of the district. Any damages done to the work or property by blasting shall be repaired immediately. Blasting may be done only to depth and extent approved by the Engineer-in-charge with explosives of approved quality and charge and in such locations are made no damage to the rock outside the prescribed limits of excavations. Explosives shall be stored in a safe place at a sufficient distance from the work and under special care of a watch & ward so that in case of accidents, no damage occurs to the other parts of works. All storing, handling, transport and use of explosives, detonators and the equipment there of shall be strictly in accordance with the Indian Explosives act and the explosives Rules-1940 and as amended from time to time.

The blasting where required shall be permitted only when proper precaution have been taken for the protection of persons and property in accordance with I.S. 40-81-1976 (Indian Standard specification for safety code for blasting and related drilling operations.) While carrying out excavation adequate precautions in accordance with I.S 3761-1966 (Indian standard Specification for Safety code for excavation work) shall be taken. Holes shall be drilled not exceeding two thirds of the depth of rock to be excavated from the elevation at which the hole is started. The holes shall not be larger than as necessary to permit easy passage of whole sticks of explosives to the bottom of the holes. As the excavation approaches its final limits, the depth of holes shall be reduced

progressively. When ever inthe opinion of the Engineer-in-charge, further blasting may injure the rock upon or against which

concrete is to be placed, the use of the explosives shall be discontinued and the excavation shall be completed by wedging, barring, Chiseling, drilling or broaching or by other suitable methods. Care should be taken to remove all loose slabs before masonry/concrete is placed for the spillway. Rock bolting compared to excavation of rock may be useful at places in excavation of foundation. The engineer-in-charge will direct where to locate rock bolt and where to excavate by wedging barring. The final prepared foundation shall roughly present a saw tooth out line and shall have at least 50% horizontal or nearly horizontal area to give resistance against sliding or as per direction.

### **Blasting with Powder**

Blasting operations shall be under charges of competent persons specifically for this purpose and be carried out during fixed hours of the day preferably during early hours midday. Lunch hour or at the close of the working day in the presence of competent persons. Prominent sign-board indicating the blasting timings should be put at a number of places. The Engineer shall see that the safety precautionare taken and observed. Red flags shall be prominently displayed and all the people except those who have actually to light the fuse must evacuate to a safe distance from the blast not less than 150 meters as a rule. Sirens shall be sounded five minutes prior to the blast with waiting note and an all clear shall be given with a long blast at the end of the operation. These sirens should be kept at different locations so as to identify the danger zones. All fuses must be cut to the required before being insertedinto the holes. The safety fuses of the charged holes are to be lighted in the presence of the superior who must see that the fuses of all holes charged have properly ignited. The number of blasts to be fired and the actual number of shots heard must be compared and the person responsible must satisfy himself by examination that all blasts have exploded before work people are permitted to approach the site. Withdrawal of a charge, which has not exploded, is not to be permitted under any circumstances, but the tamping and charge should be drilled at a distance of about 23cm. from the old hole and fired in the usual way. The result shall be carefully examined by the all persons in charge of blasting and the operation continued until the original blast is exploded.

### **Blasting with Dynamite & other High Explosives:**

Sub paras (a) of the Para 4.15.2 instruction for blasting with powder shall apply. The strength of special gelatin to be used in the excavation of foundation as per the percentage mentioned below.

60% Special gelatin for softer rock strata. 70%

special gelatin medium hard rock strata80%

special gelatin for hard rock strata

Before holes must be such a size that the cartridges can easily be passed through,and the responsible man in charge of blasting (Supervisor) shall take particular note of these positions and check them again after holes are drilled. The supervisor himself must supervise preparation of all charges necessary for thebore holes. Blasting plans shall be evolved after trial blasting at the site. The first few rounds blasted at the work site shall be considered as test/trial blasting to find the most economic and efficient drilling and firing pattern consistent with limiting the blast induced peak particle velocity (PPV) within permissible range. He shall adjust the drilling pattern, hole depth, number of holes, charge per hole and firing sequence including the types and number of

delay of ensuring most favorable angle of breakage. The blasting plan, so evolved and approved by the Engineer-in-charge will restrict the development of crack zone beyond the drilled contour and limit the PPV's influencing the damage prone features/ structures range. Through tail blasting and vibration measurement, the value of variable shall be determined from the following equation.

$$V=K (Q^{1/2})^{17/D}$$

Where V=Peak particle velocity in mm/sec

Q=Cooperating charge in 1 kg.

D= Distance from the blasting zone in meters.

K=transmission factor constant which depends upon rock characteristics homogeneity of rock and presence of faults and cracks.

Broadly, a peak particle velocity range of 70-100 mm/sec shall be permissible in good rock excavation. The number of holes to be blasted in & around will be governed by the blasting plan evolved through trial blasting as explained above with the frame work of permissible PPV. If blasting is to be done in the civility and any risk phone feature of structures, the permissible PPV shall be reduced and Engineer-in-charge shall lay down the safe limits of PPV.

### **Explosives and Blasting**

Explosives required for rock blasting are to be procured by the contractor at his own cost. It shall be the responsibilities of the contractor to store the explosive purchased by him in accordance with the rules of the explosive act and other rules framed by Government of India. Blasting materials such as gelatin, Detonators and fuse coils will have to be procured by the contractor & the contractors should make his own arrangements for their transport to work spot at his cost and their safe custody in a portable magazine, as per the rules in force and furnished the following details as per the format given below. Capacity License No. & Date Validity Period

The contractor shall acquaint himself with all the applicable laws and regulation concerning, storing, handling and the use of explosives. All such laws, regulations and rules as prevalent from time shall be binding upon the contractor.

The provision detailed in the specifications are supplementary the above laws, rules and regulations, and are also applicable except where they conflict with the above mentioned laws. Further the Engineer-in-charge may issue modification alternation and new instructions from time to time. The contractor shall comply with the same without these being made a cause for any claims. All these materials such as explosives, detonators, fuse coils tamping materials etc. that are proposed to be used

in blasting operations shall have the required make and strength. The use of fuse with only on protective coat is prohibited. The fuse shall be sufficiently water resistant as to be unaffected when immersed in water for thirty minute. Rates of burning of the fuse shall be uniform and not less than 4 (four seconds per 35 millimeters of length with 10 percent (ten percent) tolerance on either side. The fuse known as instantaneous fuse shall not be used. Before use, the fuse shall be inspected and most damaged or broken ones discarded. The rate of burning of all new types of fuse or when they have been in stock for long shall be checked before use. The detonators used shall be capable for giving an effective blasting of the explosive.

## **Personnel**

Excavation by blasting shall be permitted only under the personal supervision of competent and licensed persons and trained workmen employed by the contractor at his cost. All supervisors and workmen in charge of makeup, handling, storage and blasting work shall be adequately insured by the contractor. The storage of explosives shall be in charge of very reliable person who may if necessary cause police enquiry being made as to his reliability, antecedents etc, The contractor shall have to produce security for the person in charge of the explosives, if and as required by the engineer-in-charge of the civil authorities of the District. The contractor shall make sure that his supervisor workmen are fully conversant with all the rules to be observed in storing, handling and use of explosives. It shall be assured that the supervisor in charge is thoroughly acquainted with the details of the handling and the blasting operations.

## **Storage of Explosives**

The contractor shall build at his cost a magazine for storing the explosives and portable magazine for carrying the explosives to work spot from the magazine or one storage magazine to be built near the site of the work on which explosives are to be used. The site of the magazine, its capacity and design shall be subject to approval by the Engineer-in-charge and the Inspector of Explosives, Government of India before the construction is taken up as a rule the explosive should be stored in a clear dry well ventilated bullet proof and fire proof building on isolated site. The explosives, detonators and fuse coils shall each be separately stored. A careful and day to day account of the use of explosives shall be kept by the contractor in register in a manner prescribed by the Engineer-in-charge. The Engineer-in-charge may also pay surprise visit to the storage magazine. In case of any unaccountable storage of the explosives, or if the account is not found to have been maintained in a manner prescribed the contractor shall be liable to be penalized in which case he shall not be entitled to any compensation for the losses etc. The action taken under this cause shall be in addition to that which might be taken by the competent authorities or in the court of law. The magazine shall at all times be kept scrupulously clean. No unauthorized person shall at any time be admitted inside the magazine. A notice shall be hung near the storage prohibiting entrance of unauthorized persons.

The magazines on no account be opened during or on approach of a thunder storm and no person shall remain in the vicinity of the magazine during that period. Magazine shoes without nails shall at all time be kept in the magazine, and a wooden tub or cement trough about 300 millimeters high and 450 millimeters in the diameter filled with water shall be fixed near the door of the magazine. Person entering the magazine, must put on the magazine shoes which shall be provided by the contractor for the purpose and be careful.

- i. Not to put their magazine shoes to touch ground outside the clean floor.
- ii. Not to allow the magazine shoes to touch ground outside the clean floor.
- iii. Not to allow any dirt of grit to fall on the clean floor.

Persons with barefoot shall before entering the magazine dip their feet in water and then step directly over the barrier (if there be one) on the clean floor. A brush or broom shall be kept in the lobby of the magazine for the cleaning out the magazine on each occasion it is opened for the receipt, delivery or inspection of explosives, No matches or inflammable material shall be allowed in the magazine. Light shall be obtained from an electric storage battery lantern. No person having articles of steel or iron on him shall be allowed to enter the

magazine Oily cotton , rags waste and article liable to spontaneous ignition shall not be allowed inside the magazine workmen shall be examined before they enter the magazine to see that they have none off the prohibited articles on them. No tool or implements other than those of copper, brass, gun metal or wood shall be allowed inside the magazine. All tools shall be used with extreme gentleness and care. Boxes of explosive shall not be thrown down or dragged along the floor and shall be stacked on wooden trestles. Where there are white ants, the legs, of the trestles shall rest in shallow copper, lead or brass bowls containing water.

Open boxes of dynamite shall never be exposed to

the direct rays of the sun. Empty box or loose packing materials shall not be kept inside the magazine. The magazine shall have lightning conductor, which should be got tested at least once a year. The contractor shall within 15 days comply with all the recommendation made by the officer testing the lightning conductor, failing which the Engineer-in-charge shall entitle to comply the same at the contractor's expense which shall not open to question or the Engineer-in-charge may consider any action that he may consider fit. The following shall be hung in the lobby of the magazine.

- i) A copy of rules both in English and Oriya.
- ii) A statement showing: the stock in the magazine at the particular time.
- iii) A certificate showing the last date of testing of the lightning conductor.
- iv) A notice that "Smoking is strictly prohibited"

The magazine shall be inspected at least twice a year by an officer representing the Engineer-in- charge who shall see that all the rules and strictly complied with. He shall notify all omissions etc. to the contractor who shall rectify the defects within a period of 15 days. (fifteen days) from the date of receipt of the notice failing which the Engineer-in-charge may take whatever he considers suitable.

#### **Transport and Strong of Explosives:**

For the transport of the explosives and detonators between the store and site, closed and strong containers made of soft materials such as timber, zinc, copper, leather shall be used. Explosives and detonators shall be carried in separate boxes. For the conveyance of primer special containers shall be used. The boxes and containers used shall be kept closed. Explosives shall be stored and used chronologically to ensure the ones received earlier being use first. A make up house shall provided at each working place in which cartridge will be made up by component and licensed man as required for the work. The make up house shall be separated from other buildings. Only electric storage battery lamps will be used in this house. No smoking shall be allowed in the make up house or generally while dealing explosive. No child under 16 years of age & person who is in a state of intoxication shall be employed on the loading & unloading or transport of explosive or be employed in or allowed to enter in premises where explosives are handled and/ or stored.

#### **Disposal of Deteriorated Explosives.**

All deteriorated explosive shall be disposed off in a approved manner. The quantity of the deteriorated explosives to be disposed off shall be intimated to the Engineer-in-charge prior to its disposal.

#### **Preparation of Primers:**

The primers shall not be prepared near open flames of fire. The work preparation of primers shall always be entrusted to the same personnel; Primers shall be used as early as possible after they are ready.

### **Charging of Holes**

The work of charging of holes shall not commence before all the drilling work at the site is completed and the contractor's Supervisor be satisfied himself to the effect by actual inspection. While charging open laps shall be kept away. For charging with powdered explosives, a naked flame shall not be allowed. Only wooden tamping rods, without any kind of metal on the rod shall be allowed. The tamping rods shall have cylindrical ends. Before hole must be of such size that the cartridge can easily pass down & they shall not however be too big. Only one cartridge shall be inserted at a time and gently pressed into hole with the tamping rods, the sand, clay other tamping material used for the holes completely shall not be tampered too hard.

### **Blasting.**

Blasting shall be carried out during fixed hours of the day which shall have the approval of the Engineer-in-charge. The hours once fixed shall not be altered without prior written approval of the Engineer-in-charge. The site blasting operations shall be prominently demarcated by red danger flag. The order of the fire shall be given only by the contractor's Supervisor in charge of the work and his order shall be given by only after giving the warning signal three times, so as to be enable all the labourers, watchman, etc. to reach safe shelters. All the roads and foot paths leading to the blasting areas shall be watched. Road closing barriers should be provided to close the traffic on these roads at

least 400m away when the firing is to take place. In special case suitable extra precaution shall be taken. The Engineer-in-charge may however permit blasting for underground excavation, without restriction of fixed time provided that he is satisfied that proper precaution are taken to give sufficient warning to all concerned and that work of other

agencies on the site is not hampered. For lightening the fuse a lamp with strong flame such as carbide lamp shall be used. The contractor's supervisor shall watch the required time for the firing of the fused and shall see that all the workmen are under safe shelters in good time.

### **Electrical firing.**

Only the contractor's Supervisor in charge shall possess key of the exploder and short firing accessories and he shall keep it away with himself. Special apparatus shall be used as a source of current for the blasting operations. Power lined shall not be tapped for the purpose. The detonators shall be checked before use. For blast in series, only detonators of the same manufacturer of the same group of electrical resistance shall be used. Such electrical lines as could constitute danger for work of charging shall be removed from the site. The firing cables shall have a proper insulating cover so as to avoid short circuiting due to the contact with water metallic part of rock. The use of earth as a return line shall not be permitted. The firing cables shall be connected to source of current only when no body is in the area of blasting. Before firing, the circuit shall be checked by a suitable apparatus. After firing weather which or without an actual blast the contact between the firing cables and the source of the current shall be cut off before any one is allowed to leave the shelter. During storm changing with electrical detonators shall be suspended. The charges, already placed in the holes shall be blasted as quickly as possible but taking all the safety precautions, and giving necessary warning signals. If this is not possible the site shall be abandoned till the storm has passed.

### **Precaution after Blasting**

After the blast the contractor Supervisor must carefully inspect the work and satisfy himself that all the charges have exploded. After the blast is taken place in underground works, workmen shall not be allowed to go to the place till all the toxic gases are evacuated from the face.

### **Misfires**

If it suspected that part of the blast has failed to fire and delayed, sufficient time shall be allowed to elapse before entering the danger zone. When fuse and blasting caps are used a safe time should be allowed and then the contractor's Supervisor alone shall leave the shelter to see the misfire. None of the drillers are to work nearer this hole under one of the two following operations have been carried out by the supervisor. Either (i) the supervisor should very carefully extract the temping with wooden scraper or jet of water or compressed air using pipe of soft materials and withdraw the fuse with the primer and detonator attached after which a fresh prime and detonator with fuse should be placed in this hole and fired out (ii) the hole may be cleared of 300m of capping & the direction be ascertained

by placing a stick in the hole. Another hole may be drilled at least 225mm. away and parallel to it.

This hole should then e-charged and

fired. The balance of the cartridge and detonators found in the muck shall be removed. Before leaving this work the contractor's supervisor should inform the supervision of the relieving shift of any case of misfires and should point out the position with Red Cross denoting the same also stating what action if any he has taken in the matter. A register of misfires and their location and how they were dealt with shall be maintained by the contractor. The contractor's Supervisor should also at one report at the contractor's office all cases of misfires, the cause of the same and what steps were taken in connection there with. The name of the day and night shift supervisor of the contractor must be noted daily in the contractor's office if misfire has been found to be due to defective detonator or dynamite the whole quantity of box from which the defective article was taken must be returned to the contractor's office for inspection and shall be disposed off as per rules & regulation of the act. Blasting operation when considered necessary shall be restored to only with written permission of the Engineer-in-charge. Prior inspection shall be carried out for the safety & stability of the public and property. Blasting operation in the proximity of overhead power line, communication line utility lines or other structures shall not be carried on until the operator or the owner of both such lines have been notified and precautionary measures deemed necessary have been taken. Any damage to the neighboring building properties, standing crops and life due to blasting shall be made good by the contractor at his cost.

### **General**

The price included in the schedule for the work required by this section shall be all inclusive constituting full compensation for mobilizing, demobilizing and supplying all equipment, materials, labour, supervision and all incidental work except for any item specifically exempted there from and for which in addition specific payment item has been included in the schedule.

### **Common Excavation**

Measurement for all works done should be on the level sections initial levels and final levels will be taken at every 3m square grid and the contractor shall accept such levels, either in the book or graph sheets, or in both as directed by the Engineer-in-charge. If the dumps the excavated materials in an irregular way or not confirming

to the dumping specifications, the department will withhold 20% (of the rate) and the same can only be released after the work is completed up to the foundation grade. No allowance shall be made for over excavations beyond the specified minimum lines of excavations except where specifically authorized. No extra payment for any over breakage and subsequent repairs shall be payable and deemed to have been included in the applicable item of schedule of bid.

Payment of common excavation shall be made on the basis of the unit price entered for the particular item in the schedule.

### **Excavation of Soil and Disintegrated (D.I) Rock**

Excavation of soil shall comprise of all kinds of soil such as vegetable or organic soil turf, sand, silt, loam, clay mud, peat, black cotton soil, loose or compact moorum, soft stiff/heavy/hard shale, stony earth mixed with gravel having 300mm maximum diameter in one direction. Excavation of D.I. shall comprise of soling of roads/paths, hard core, macadam surface, lean, concrete, stone masonry, brick work, soft conglomerate, lime stone, sand stone, laterite, hard conglomerate and types of D.I. rock, which does not require blasting and can be quarried or split with pick axe and crow bars. If however the contractor resorts to blasting in such strata and D.I. rocks for his convenience, no extra payment shall be made the materials shall not be classified in higher grade. Excavation for canal shall conform to provisions of relevant I.S codes, Sides slopes are to be provided as per the approved drawings, specification and provision of I.S code.

### **Excavation of Medium Hard Rock**

This shall include all solid rock in place of such hardness and texture that it can not be removed by pick axe and crowbars and only to be removed by means of appropriate blasting. All boulders or detached pieces of solid rocks having volume greater than 0.50 cum, can be classified as Medium Hard Rock. The excavated rock and debris so obtained shall be carried and dumped/stacked separately with varying lead at places indicated by the Engineer. The excavated materials shall be the property of the Department. Payment for medium Hard Rock by means of appropriate blasting shall be made as per level section (Pre & finished). A closer interval for leveling may be adopted if considered necessary as per opinion of the Engineer-in-charge. Boulders having volume more than

0.5 cum shall be pre measured.

### **Over Excavation**

The foundation excavation shall be made to exact designed section in all kinds of soil and D.I. rock. No over excavation will be allowed in such reaches. However, in Medium Hard Rock formation over excavation to the extent of 10 cm. depth on an average will be allowed and paid for in the respective item. In case of over excavation beyond 10 cm depth due to poor geological formation certified by the Superintending Engineer and approved by the Chief Construction Engineer payments would be made for removal of such quantity only.

### **Rock Excavation**

Measurement for payment of medium hard rock and sheet rock excavation in open cut as required by this section shall be made of the total volume of rock in cubic meters contained, within the minimum lines for such excavation shown on the drawings or as specifically directed. The profile of the original rock surface, prior to excavation shall be established by taking levels of 3M. square grid. The final levels on finished surface shall

similarly be taken on a 3M square grid on concurrent points as that of initial grid. With these profiles, the quantities on rock excavation shall be worked out. In case hard rock boulders met during excavation for which blasting is restored, the contractor is required to take

up blasting & stack the blasted debris in closely packed stack as directed by the Engineer-in-charge and payment will be made for the solid quantity of rock calculated after deducting. No allowance shall be made for over excavation beyond the minimum lines the excavation except where specifically authorized. No extra payment for any over breakage and subsequent repairs shall be payable and deemed to have been included in the applicable item of the schedule of bid. If the contractor dumps the excavated rock in an irregular way or not conforming to the dumping specifications, the department will withhold 20% of the rate and the same can only be released after the contractor removes the materials to the proper place for dumping. Payment for rock excavation shall be made on the basis of the unit price entered for the particular item in the schedule.

### **3.4.23 Dewatering:**

#### **General:**

Dewatering shall be carried out by the contractor at his own cost & as per approval of the Engineer in charge to enable excavation, mucking, inspection, final preparation of the surface, providing anchor bars, grouting, laying of concrete & masonry and allied constructional activities.

### **3.4.24. Dewatering by Electrical/Diesel Pumps**

Electric/Diesel Pumps (as approved by the Engineer-in-charge) of requisite capacity shall be installed in order to handle seepage. In case of electric pumps circuits shall be isolated from any other electric installation and the switch gears and pumping equipment shall be maintained in satisfactory condition to avoid loss of energy. If diesel pumps are used, all costs of POL, running and maintenance shall be borne by the contractor deemed to have been included in the unit price of the particular item in the schedule of bid. Similarly the cost of electricity, running and maintenance of electric pumps, if used, shall be deemed to have been included in the unit price for the particular item in the schedule of bid. No payment will be made separately for de-watering. All dewatering is to be done at the contractor's cost and the rates for all items should include the dewatering operation.

#### **Anchor Bars in Rocks**

#### **Drilling Holes for**

#### **Anchor Bars**

Where ever shown in the drawings or as directed, holes shall be drilled into the rock to receive bars for anchoring concrete, masonry and ground mat to the rock. The dimension of the anchor bars and the location diameter and depth of anchor bar holes shall be as shown in the drawings or as directed. The diameter of the anchor bar holes shall be not less than 15 times the diameter or the greatest transverse dimension of the anchor bar specified for that holes.

#### **Placing Anchor Bars and Grouting**

Anchor bars should be cleaned thoroughly before being placed. The holes shall be cleaned thoroughly, kept flagged until placing the bars and shall be filled completely and compactly with grout or mortar mixed in the proportions and to the consistency specified by the Engineer-in-charge.

All water shall be removed from the hole when the anchor grout is placed. The anchor bars shall be forced into

place before the grout or mortar has taken its initial set and where practicable shall be vibrated sufficiently so that entire surface of the embedded portion of the bars is in intimate contact with the grout. Special care shall be taken to ensure against movement of the bars, which have been placed. Anchor bars shall be placed and grouted not less than 6 days in advance of concrete/masonry operations to allow the grout to set. Anchor bars found loose after setting shall be replaced by the expense of the contractor.

### **Measurement and Payment**

The price entered in the schedule for this work required by this section shall be inclusive of mobilization, demobilization, cost of all materials, labour supervision and all incidental works including all leads, lifts, delifts, charges for loading, unloading, cost of materials, conveyance, taxes and all operation etc. complete.

### **Refilling with Sand in Foundation**

The sand required for refilling the foundation of the structure bays founded on clay or the deep scour holes shall be free from clods of clay and other deleterious substances and laid in layers of 300mm with profuse watering. The materials excavated from the foundation of the adjoining area can be used for filling subject to its suitability and approval by the Engineer-in-charge.

### **Embankment (Afflux bund & Guide bund)**

#### **General.**

Embankment shall be constructed to the lines and grade with earth fill having desired parameters of density, cohesion, permeability etc. so as to ensure the designed stability and performance of the whole embankment. The quality control organization of the Department will carry out requisite tests for the suitability of the construction material well in advance and the contractor shall ensure that only approved materials are brought to place of fill and used for construction of embankment.

#### **Foundation preparation subsequent to stripping and excavation.**

Soil Foundation: Soil foundation under the seat of embankment shall be scarified and loosened by means of a plough, ripper or other means to a depth of about 15 cm to 20 cm to the satisfaction of the Engineer-in-charge. Roots or other debris turned up during scarifying shall be removed from the entire foundation area for the fill. It shall then be moistened to slightly above the optimum moisture and compacted by required number of passes of the compaction equipment to the same percentage of compaction as that of embankment. The purpose of using higher moisture than optimum is to ensure forcing of the soil into any unseen soft zones just below the surface. The first few layers of fill for the embankment shall be of depth of 10 cm to 15 cm and shall be carefully placed, ensuring uniform compactions and a satisfactory intimate bond between the foundation soil and fill materials. Heavy rubber tyre rollers or vibratory rollers may be used for compaction because they will follow the irregular surface and not bridge over small low areas as other type of rolling equipment will do. Sheep foot rollers shall be used for compaction of impervious soil and preferably vibratory type rollers shall be used for compaction of all other soil and rock. Separate payment shall not be made for preparation of foundation as above and it shall be deemed to have been included in the unit rate quoted for respective item of embankment.

Sand Foundation: Sand met within foundation shall be tested for its lateral relative density. In reaches where the relative density is less than 70% the foundation sand shall be compacted by any of the approved methods to obtain a minimum relative density of 70% until the foundation has been tested and the relative density found to exceed 70%, earth fill shall not be allowed to be placed. This is necessary to minimize the effect of any structural readjustment in a loose foundation.

## **Borrow area**

### **GENERAL**

All materials required for the construction of embankment and around the structures shall be obtained from borrow areas after stripping and duly approved by Engineer-in-charge in consultation with quality control unit of the department only if the materials available from excavation of foundation of the structure and ancillary works are found to be unsuitable for use in construction of the embankment. The contractor has to borrow earth at his own cost and responsibility. No Compensation whatsoever for acquiring land for borrow area and for change in limits and locations of the borrow areas and depth of cut for getting suitable earth shall be paid to the contractor. No excavation is allowed within a distance of ten times the height of embankment from the outer roe. Borrow pits shall be operated so as not to impair the usefulness or mar the appearance of any part of the work or any other property. The surfaces of wasted materials shall be left in a reasonable level and even condition.

### **PREPARATION OF BORROW AREAS**

All areas required for borrowing earth for embankment shall be cleared of all tree stumps, root, bushes, rubbish and other objectionable materials. Adequate lighting arrangement should be provided by the contractor. Particular care shall be taken to exclude all organic matters from the materials to be placed in the embankment. All cleared organic materials shall be burnt to ashes or disposed off as directed. The cleared areas shall be maintained free of vegetable growth during the progress of the work. No payment shall be admissible for preparation of the borrow areas indicated above as this is deemed to have been included in unit bid price.

### **STRIPPING OF BORROW AREAS**

Borrow areas shall be stripped of top soil, and any other objectionable materials to the required depth as approved by Engineer-in-charge. The work may be done manually or with suitable machines. Stripping operations shall be limited only to designated borrow areas. Materials from stripping shall be disposed off in exhausted borrow areas or in the approved adjacent areas as directed. No extra payment shall be admissible for stripping the borrow areas as this is deemed to have been included in the unit bid price.

### **HAUL ROADS AND APPROACH ROADS**

Construction and maintenance of approach roads and haulage roads will be the responsibility of the Contractor, as per the direction of Engineer-in-charge. The department will have full left of use to those roads for inspection purposes. Proper road sign as required have to be provided for safety. For haulage of earth, the contractor shall construct ramps and haulage of sufficient width along the shortest but most practical route and shall maintain

and illuminate them in a satisfactory manner. Watering of the haul road shall be done by the contractor as often as necessary to prevent rising of dust, formation of cuts and consequent deterioration of the surface. Whenever service roads meant for public through fare traverse through or run close to the borrow area, the Contractor shall direct his excavation and haulage operation in such a manner as to ensure uninterrupted use of the service road and safety to the public. At the haul road and service road crossing the contractor shall install necessary check gates and road signs. No Extra payment for haul road is admissible as this is deemed to have been included in the unit bid price for earth work item of schedule of quantities being contingent to the man work.

### **Earth Fill Material.**

#### **HOMOGENEOUS EARTH FILL**

Embankment shall be constructed to the top width and side slopes as shown on the drawings. Suitable excavated materials available from ground cutting, removal of ramps and excavation for structures shall be used for construction of banks. If suitable and adequate materials for constructing embankment is not available from excavations, the desired material shall be obtained from approved borrow areas after getting approval of the Engineer-in-charge. The planning for execution should be such that all the useful excavated materials are utilized in embankment prior to utilization of borrow earth from outside. (i) Only suitable materials under classification shall be excavated, loaded and conveyed to the point of placement in the embankment. Unsuitable materials if conveyed will be removed and disposed clear of the work site as directed by the Engineer-in-Charge at the cost of the Contractor. The maximum dimension of stones, pebbles and rock fragments etc. placed in the outside zone of the embankment shall not be more than 15 cm and the quantity of such stone shall not exceed 5%. (ii) Construction of embankment shall begin at the toe of the fill and in no case shall embankment be widened by material dumped from the top. The material shall be placed in the earth fill in the continuous horizontal layers not more than 15cm in thickness after being rolled as herein specified. The thickness of the layer shall be adjusted by the Engineer-in-charge, if the contractor satisfies the department that the particular type of compactors used by him give the required density as specified in drawing by carrying out trial compaction and requisite tests. The thickness of horizontal layers

after compaction shall not be more than 10 cm if compaction is performed by mechanical tampers and not more than 15 cm if compaction by sheep foot rollers. Initially the earth in the embankment fill will be laid in a greater width than the designed section. Adequate extra width of about 0.6 m on either side of the embankment shall be provided so that the earth fill up to lines of the finished slopes shall have the required compaction as per the drawing and specification. Such extra width shall be removed and utilized in the upper layers of embankment along with slope dressing for which no additional payment will be made as it is deemed to have been included in bid price for respective item. (iii) No fresh layer shall be laid the previous layer is properly watered and compacted as per the requirement. If in the opinion of the Engineer-in-Charge, the surface of the prepared foundation or the rolled surface of any layer of earth fill is too dry or smooth to bind properly with the layer of materials to be placed thereon. It shall be moistened or worked with harrow, scarifier or other suitable equipment in an approved manner to a sufficient depth to provide a satisfactory binding surface with the next succeeding layer of earth fill. If a layer is found to be too wet for proper compaction of the layer of earth fill materials to be placed there on, it shall be raked up and allowed to dry or be worked with harrow, scarifier or any other suitable equipment to reduce the moisture content to the required amount and then it shall be

compacted before the next succeeding layer of earth fill materials is placed. (iv) The materials shall be deposited in row parallel to the axis and spread in the uniform layers and breaking clods maximum up to 5 cm. sizes. Loads shall be dumped and spaced so that the progress of spreading shall produce adequate blending resulting in uniform layers not exceeding 22.5 cm. The work of spreading and compaction shall be so adjusted as not to interfere with each other and in such a way that neither of the operations is held up because of non-completion of rolling and watering. The excavation and placing operations shall be such that the material when compacted shall be blended sufficiently to secure the best practicable degree of compaction, impermeability and stability. The surface of banking shall at all time of construction be maintained true to required cross section.

(v) During construction a small transverse slope from centre towards edges should be given to avoid pools of water forming due to rains. Embankment materials shall be placed only when the weather conditions are satisfactory to permit accurate control of the moisture content in the embankment materials. Before closing work on embankment, in any continuous reach prior to setting of monsoon, the top surface shall be graded and rolled with a smooth wheeled roller to facilitate run off. Prior to resuming work, the top surface shall be scarified and moistened or allowed to dry as necessary and approved by the Engineer-in-charge for resumption. The contractor shall provide suitable protection works to protect the slope from erosion due to rain water. No payment whatsoever shall be made for providing such protection work and rectifying the monsoon damages.

### **3.10.3. MOISTURE CONTROL:**

The water content of the earth fill material prior to and during compaction shall be distributed uniformly throughout each layer of materials and it shall be between +2% to (-)2% of the optimum moisture content. Moisture determination of soil as well as determination of needed moisture shall be carried out as per designations of Earth Manual (July '74 second reprint 1985) and IS 2720-1983. Flooding at borrow area for preconditioning of moisture is preferable and effect only correction for moisture in the embankment. As far as possible the moisture content of the material shall be conditioned prior to its delivery on the embankment. It is preferable to use sprinkler for moisturing earth fill over the embankment use of jet of water for moisturing should be avoided. In order to have proper control of moisture content in the earth fill, no earth work will be done during rainy days. No compensation will be made to the contractor due to held up of work for rain, fog and high moisture content in the working process.

#### **Compaction**

##### **General**

(i) Having decided on the filling materials to be used, standard compaction test shall be made on the materials proposed for embankment to indicate broadly which are the most suitable and to give a rough idea of the best type of equipment to be used and the moisture content at which compaction should be undertaken and also to determine the effects of soil moisture content, thickness of layer and number of passes. (ii) Having decided on the thickness of layer and range of moisture contents, test should be made with different type of equipments available and the required number of passes should also be determined.

(iii) In all this work, the state of compaction should be measured in terms of dry density. (iv) Density tests shall be made after rolling, standard proctor density test shall be carried out at regular intervals to account for variations in the borrow area materials as well as that in-situ excavated materials. Not less than three tests shall be carried out to indicate variations in the standard proctor density attained in the laboratory.

- (v) Density test shall be conducted from time to time on site to ascertain whether the compactions attained as specified. For every 1500 cubic meters of compacted earth work, at least one field density test shall be taken. Minimum four density tests shall be taken per day irrespective of quantity of earthwork. In case the tests show that the specified densities are not attained, suitable measures shall be taken by contractor either by moisture correction or by entire removal and relaying of layer or by additional rolling so as to obtain the specified density which shall be checked again by taking fresh tests at the same location. Each layer shall be tested after rolling for proper compaction and after that fresh layer over it will be allowed. Necessary unskilled labour required for carrying out such density tests shall be provided by the contractor. However testing charges shall be borne by the department.
- (vi) Contractor shall supply all materials, labour, machinery and equipment at his cost for the work.
- (vii) No extra payment shall be made for these operations as this shall be deemed to have been included the price bid in schedule of quantities for the respective items of work.

### **Rolling.**

When each layer of materials has been prepared so as to have the proper moisture content uniformly distributed throughout the material it shall be compacted by passing the tamping roller. The exact number of passes for each layer to obtain specified density shall be designed by the field laboratory after necessary test. The layers shall be compacted in strips overlapping not less than 0.6m. Rolling shall commence at edges and progress towards center longitudinally. The rollers of loaded vehicles shall travel in a direction parallel to the axis of the embankment. Turns shall be made carefully to ensure uniform compaction. Rollers shall always be pulled. Density tests shall be made after rolling and dry density attained shall satisfy the specified compaction standards. Standard proctor density test shall be carried out at regular interval to account for variations in the borrow area materials as well as that in-situ excavated materials. The locations where compactions of the earth fill materials by means of the roller is impracticable or undesirable the earth fill in that locations shall be specially compacted by means of pneumatic tampers.

### **COMPACTION OF COHESIONLESS MATERIALS:**

Where compaction of cohesion less free draining materials such as sand and gravel is required, the materials shall be deposited in horizontal layers and compacted to the relative density specified. The excavation and placing operations shall be such that the materials when compacted shall be blended sufficiently to secure the highest practicable unit weight and best stability. Water shall be added to the materials as may be required to obtain the specified density by method of compaction being used. The thickness of the horizontal layers after compaction shall not be more than 10 cm if compaction is performed by tampers, not more than 15cm. if by rollers. The relative density of compacted materials shall not be less than 85% as determined by laboratory test.

### **Dressing slopes**

The outside slopes of the embankment shall be neatly dressed to lines and grade as shown in the drawing as the placing of fill progresses. Compaction shall extend over the full width of the embankment and material in slopes shall be compacted as for the rest of the bank. To ensure proper compaction of the edges, the cross section of the fill during construction shall be kept suitably wider as directed by Engineer-in-charge and cross section shall be dressed to the designed requirement after compaction for which no extra payment shall be made

as it is deemed to have been included in unit bid price for item of schedule of quantities. Material used to fill depression shall be of same type as used in the embankment and shall be thoroughly compacted and bonded to the original surface. Slopes shall be maintained till final completion and acceptance. Any material, that is lost by rains, weathering or other causes shall be replaced at the cost of the contractor till completion of the works and taking over by the Department.

**Settlement Allowance:**

In the earth fill embankment, settlement allowance of 2% will be provided. Accordingly extra height shall be provided but payment for design height will be made. The base width of the embankment will not be increased to maintain the design slopes indicated in the drawings for the additional height as settlement allowance, but the following procedure will be adopted. Settlement allowance will be calculated at various levels where the slope is to be changed and the elevations including settlement allowance will be derived, keeping the embankment widths at the designed levels unchanged. The edges of embankment at the increased elevations (including settlement) when joined with the point where the slope has changed earlier below, shall give the slope to be adopted for construction. If the embankment is raised in more than one season provision for settlement shall be made in the last season's construction as described above.

**Measurement and Payment (Earth fill):**

**MEASUREMENT FOR PAYMENT.**

- (a) All works shall be measured by levels.
- (b) For payments the level books, field book, the cross section sheets and calculation sheets shall be treated as adjuncts to the measurement books. (c) All linear measurements shall be in meters, correct to 0.01 meter, area worked out in square meter correct to 0.01 M<sup>2</sup> and volume worked out in cubic meters correct to 0.01 M<sup>3</sup>.
- (d) The quantities between the levels taken after stripping and cross sectional levels taken after construction of consolidated embankments under OMC conditions with the available useful excavated soils within the designed section shall be worked out excluding riprap, rock toe and filters etc. It shall be clearly understood that construction of embankments to extra widths as specified above and extra height formed for settlement allowance as specified earlier will not be included for payment.
- (e) The measurement for construction of consolidated embankments with the materials obtained from the borrow area shall be the difference between the net quantities of the final compacted embankment section under OMC and net quantities of compacted embankments constructed with the suitable materials from all excavations as specified above and in earlier paragraphs. Final measurements and levels shall be taken at the cross sections of the completed compacted bank design section after the slopes dressed to ensure that the work is completed as shown on the drawings plus settlement allowances. The measurements for computation of quantities shall not include the extra section provided for compaction of earth fill up to lines of finished slope and for settlement height.

## **RATE FOR PAYMENT:**

The rate for embankment fill under the item provides all costs for labour, materials, tools and plants, machinery, token excavation, transportation and incidental operations required for carrying out and completing the item of work in accordance with the specification, drawing and as directed by Engineer-in-charge.

### **Fine Dressing and Turfing on the outside slopes.**

The outside slope of the embankment as per line, grade and dimensions of the drawing shall be protected by turfing the entire slope including the berms. After the slope has been fine dressed to the line, it shall be roughened or packed evenly without any additional cost. The entire surface shall then be covered with a layer of dub grass sods consisting of blocks or strips of dense living grass growth as approved. The sods shall include a mat of root and earth at least 5 cm. thick. Sods containing an excess amount of obnoxious growth shall be excluded. Sods shall be carefully handled in transportation and transplantation so that minimum amount of earth will be lost from the root mass. The strips of blocks of sods shall be laid on the slope in close contact and then tamped firmly in place so as to fill and close joint between the blocks. Interval of time between collecting and laying shall be kept to a practical minimum and sods shall not be permitted to dry out. Immediately after placing the sods slopes shall be periodically moistured and if necessary for a sufficient period to re-establish the plant growth. Sods shall be transplanted generally from July to November. Arrangement of suitable sods is the responsibility of the contractor. The contractor will maintain the earth fill at his own cost till the items of turfing is completed. The measurement is to be made on the covered area basis and item will be paid at the bid price for finished item after survival of the turf for reasonable period as determined by the Engineer-in-charge. The unit bid price shall be for the finished item including the collection transportation within all lead, all lifts and de-lifts, loading, unloading, surface preparation, transplantation, tamping, watering till survival of sods, all labour, materials, taxes, tools, equipments and all incidental operations necessary to complete the work as per specification and as per direction of Engineer-in-Charge.

### **Inspection and Tests**

#### **GENERAL**

The Engineer-in-charge shall maintain and exercise a thorough check on the quality of fill materials delivered to the embankment and will arrange to obtain the data-in-situ properties of the materials after compaction for comparison with design assumption. To achieve these objectives, a programme of fill testing and inspection shall be planned to effect quality control.

#### **SCOPE OF TESTING AND INSPECTION REQUIRED.**

Field control of fill materials will require visual and laboratory checks. The checks on the effectiveness of placement and compaction procedures shall be made by field density test at prescribed intervals. The control shall be both of the method type and on an end result basis. Department might review the design if necessary on examination of density test result and the contractor shall have no claim arising out of such a review and consequent change, if any, in the design.

#### **EMBANKMENT TEST SECTION.**

Placement and compaction methods specified will have to be verified by test embankment section to be built prior to starting of fill operations or at an early stage of construction. Either the initial stage of construction itself could be made to serve the purpose of test embankments or test embankment sections can be established in borrow areas. The test sections referred herein shall be used to establish:

- a) Layer thickness of fill materials.
- b) Optimum Practicable moisture content.
- c) Number of passes of sheep foot roller or weight of laboratory rollers vis-à-vis number of passes for effective compaction.
- d) For pneumatic tyred compaction equipment, the test required will be such as to determine the most suitable loading, tyred pressures, moisture contents and number of coverage for compaction of the materials. Using the available data from borrow pits, investigations of the materials to be used in the test section, the optimum moisture content as determined by laboratory tests will be known and 3 percent less than this moisture content should be used in the first 3 or 4 layers rolled. After 3 or 4 layers have been placed at 3 percent less than the laboratory optimum moisture content, field density tests should be made throughout the section. These tests should be made for at least each 100 sq. meter of test section area, and should be distributed over the area that they will depict the effects of different compacting conditions encountered during construction. For example, if the section is located near an abutment, certain parts of the area will receive more compaction from track travel than other, hence some tests should be made in the portion compacted early by the rollers and so restored. The next step is to compact another 3 or 4 layers at the moisture content slightly higher (1 percent or 2 percent) than the moisture content previously used, maintaining the same rolled thickness of layer and number of roller passes as in above. Field density tests are again made over the test section. If the resulting field dry densities (of material passing the No.4 sieve) show an increase with increase of moisture, then increase the moisture again by another 1 percent or 2 percent and repeat the test. If an increase in moisture results in a decrease in field density, then place the next layer slightly dry of the original moisture content used and repeat the test. This procedure is nothing more than developing on the embankment a moisture density relation or compaction curve for certain roller, thickness of layer and a given number of roller trips. If special studies during investigations have indicated that material being tested should be placed within certain moisture limits or if the moisture limits to be used have been specified, the procedure outlined above should include test at these moisture contents or at moisture contents.

#### **BEFORE COMPACTION.**

Materials delivered to the fill shall be visually examined and their properties estimated by way of inspection. i) Moisture content tests shall be carried out in the laboratory while placing the fill materials. ii) Moisture content shall be controlled by adding water or allowing the soil to dry according to laboratory tests. iii) It shall be ensured that the methods of dumping, spreading and moisture conditions are such as will, result in reducing segregation and/or variation of moisture content to minimum.

#### **DURING COMPACTION**

It is intended that the checks on operations during compaction shall verify : i) That the layer thickness of the materials is specified. ii) That the fill is compacted to required standard proctor density or relative density by

the specified number of passes of specified machinery. iii) That no excessive rutting, weaving or a scaling of the fill occurs during compaction.

### **AFTER COMPACTION.**

The condition of the fill after compaction shall be observed and recorded particularly with respect to cutting or weaving. However, the properties of materials after compaction shall be determined primarily by field density tests. Routine tests on samples taken from constructed embankments shall include, besides Density tests, Grain size distribution, Atterberg limits, Shear and consolidation characteristics.

### **FREQUENCY OF TESTING**

a) It will be necessary to carry out sampling and test of materials before and after compaction at sufficient frequencies so that effective checks on the fill operations are maintained. The testing frequencies proposed should correspond to the frequencies as shown in Annexure-I. However, the actual frequencies should be adjusted to suit the nature and variability of materials placed and the rate of fill placement. b) Testing shall be performed at higher rates than those given in Annexure -I, during initial stages of placing in order to establish control and testing techniques. Also testing shall be conducted at higher rates in case of special problems such as materials variation, equipment performance and weather. c) In addition, these tests shall be made i) in area where the degree of compaction is doubtful. ii) in area where embankment operations are concentrated. iii) at the locations of all embedded instruments for record. d) Locations of likely insufficient compaction shall cover the following or any other area so determined by Engineer-in-charge. i) The junction between areas of mechanical tamping and rolled embankment along abutments or cutoff walls. ii) Areas where rollers turn during rolling operations. iii) Areas containing materials differing substantially from the average.

### **RECORDS AND REPORTS.**

Records of borrow area materials and embankment placing operations shall be maintained in order to have a continuous check on the suitability and availability of fill materials and quality of the fill. Thus it will be possible to have complete description of materials in any portion of the embankments. A foundation register is to be maintained in approved format for passing of the foundation by competent authority. No fill material to be placed on any part of the foundation unless foundation is inspected, surveyed and approved in writing and cleared by flagging for daily work.

### **Protection**

The contractor shall take all precautions necessary for the protection of the embankment work by diversion of stream, local surface drainage, rain water etc. if these are likely to damage the work. Any damage to earth work due to any reason what so ever shall be made good by the contractor at his cost till the work is certified as completed and taken over by the Department.

### **Applicable Standard.**

Publication of Bureau of Indian Standards (BIS) Indian Standard

(i) IS: 1948-1970 Classification & Identification of soils for General Engineering purpose (First revision)

(ii) IS: 1988-1982 Methods of load test on soils (Second revision)

- (iii) IS: 2131-1981 Methods for standard penetration test for soils (First revision).
- (iv) IS: 4332-1967 Method of sampling and preparation of established soils for testing (Part-I)
- (v) IS: 4558-1983 Code of practice for under-drainage of lined canals (First revision)
- (vi) IS: 4701-1982 Earth work on canals (First revision)
- (vii) IS: 5529-1969 Test in Over burden (Part-I)
- (viii) IS: 7894-1975 Code of practice for stability analysis of earth dams.
- (ix) IS: 8414-1977 Guidelines for design of under seepage control measures for earth and rock fill dams.
- (x) IS: 8419-1977 Filtration media – sand and gravel (Part-I)
- (xi) USBR Earth Manual by United State Bureau of Reclamation. Earth Manual.
- (xii) Quality control Irrigation & Power Dept., Govt. of Odisha. & Field instruction. Manual (1989)

**ANNEXURE – I**

**(See Clause 3.5.10.7)**

**TESTING FREQUENCY**

**Material Volume or Time between Tests Remarks before compaction After compaction**

**Gradation**

**Moisture content**

**Field Density**

**Permeability**

**Triaxial shear tests**

**Consolidation test**

**1 2 3 4 5 6 7 8**

Back filling with selected materials in the back side of abutments, flank wall and the existing flood protection embankment.

**General**

- a) The type of material used for back fill, and the manner of depositing the material shall be subject to approval by the Engineer-in-charge. As far as practicable, back fill material shall be obtained from the excavation for structures or from excavation of other ancillary works. Back filling shall be restricted until structure is completed. The back fill materials shall only be procured from the site other than excavated pit of the structure when the quality of excavated materials is found unsuitable or the quantity insufficient. The decision of Engineer-in-charge is binding regarding the disposal of excavated material in the dumping yard or to be utilized as back fill materials. The schedule of construction of components of civil works should be prepared such that the maximum amount of excavated material if found suitable should be utilized as back fill materials.
- b) Back fill materials shall contain no stones large than 7.5 mm size.

c) The previous materials (sand) with profuse watering used for back filling in the back of abutment flank-wall shall be placed as shown on drawing or as directed by Engineer-in-Charge. d) Back fill shall not be placed against retaining walls until the retaining wall is cured adequately and is strong enough to take lateral pressure of the back fill. e) The back fill material shall be placed carefully and spreaded in uniform layers not exceeding 15 cm. The back fill shall be brought up as uniformly as practicable on both sides of walls and all sides of structures to prevent unequal loading. The back fill material shall be placed at about the same elevation on both sides of the structure and difference in elevation shall not exceed 15cm at any time. Black cotton soil should never be used as back fill material. Tamping to be used for compaction of the back fill immediately adjoining the structure.

**Measurement and Payment.**

Measurement for payment for back filling around structures will be made according to the pay line given or the drawings and the back fill outside of those pay lines will be at the cost of the Contractor.

The payment shall be made on cubic meter basis under relevant items of schedule of quantities.

**CHAPTER-IV.**  
**ROAD WORK**

**GENERAL**

1. Road shall be constructed to the lines, level and grade with sand and moorum fill having desired parameters of density cohesion, etc. so as to ensure the designed stability and performances of the whole road. **The Quality Assurance Division, Samal** may carry out requisite test for the suitability of construction materials well in advance and the contractor shall ensure that only approved materials are brought to place of fill and used for construction of Road.
2. The difference in elevation of the approach road during construction within each working length of not less than 50M shall not exceed 1.0M anywhere in the cross section unless specifically permitted by the Engineer-in-Charge placing of the layers for the road portion programmed for construction in the season shall be continuous and approximately horizontal. In case the whole length of road is not constructed simultaneously, the incomplete end of the road shall be kept at slope not steeper than 1 in 4.
3. No materials shall be placed in any section of the road until the road seat for that section has been dewatered, suitably prepared and approved by the Engineer -in-Charge. All portions of excavation made for test pits or other sub-surface investigations, all holes, hollows, and all other existing cavities found within the area to be covered and which extend below the established lines of excavation for road seats, shall be filled with suitable earth fill of the corresponding zone of the road and suitably compacted.
4. Pools of water shall not be permitted in the foundation for road and such water shall be drained and cleared prior to placing the first layer of road materials. The contractor shall construct and maintain good diversion in case the existing communication are disturbed. Precautionary measures such as night lamp, danger fencing signals shall be provided by the contractor at his cost to avoid accidents on the communication lines because of contacts activities.

#### **SETTING OUT OF THE WORK**

1. In the vicinity of the road, there are permanent Bench Marks fixed by Survey of India. Temporary Bench Marks shall be set up by the department at every 1.0 km interval at convenient locations along the road to serve as control points. The contractor shall establish sufficient numbers of reference Bench Marks for facilitating the setting out and taking levels for measurement of work with the approval of the Engineer-in-Charge at his own cost. The Bench Mark shall be 30cm X 30cm X 75cm with concrete pillar, which shall be embedded 55cm into firm ground and 20cm projecting above the ground. The Bench Marks shall be constructed in plain C.C. M-10. These pillars shall be well protected from being disturbed. The word B.M. showing value of R.L. shall be conspicuously carved and painted on the Bench Mark.

- 2 Before starting any work and during execution (if required) the contractor shall erect reference Bench Marks, reference lines and check profiles at convenient locations as per the direction of the Engineer- In-Charge. The centre line of the road and the reference line for all alignments for demarcation purposes shall be laid by properly dug-belled on the ground.
- 3 The Check profiles shall be located at 30M. apart or closer as directed by the Engineer-In-Charge so as to ensure execution of all slopes, steps and elevations, to the profile as indicated in the approved drawings. All important levels and all control points with respect to Bench Marks and reference lines shall be fixed and co-related by the Engineer-In-Charge.
- 4 To ensure correctness of execution the edges of cutting, the lines of the road and those of spoil bank shall be marked carefully with pegs at close enough intervals so as to obtain a layout in plan free from banks. The pegs shall then be connected by stretching string from peg to peg and dug belling into ground along the strings. The lines so connected shall be corrected whenever necessary to provide a stream lined plan of the features. Special care shall be taken at curves to ensure uniform curvature of the alignment. The layout of the structures shall have to be given in appropriate manner with pegs & pillars. ;
5. All materials and labour for settings out works including construction of reference Bench Marks, reference lines check profiles and surveys, as may be required at the various stages of the construction, shall be supplied by the contractor at his own cost. The cost of such works shall be deemed to have been included in the costs of items in schedule.

#### **PREPARATION OF SITE**

##### **1 CLEARING THE SITE**

- (a) The contractor shall clear the entire area required for setting out, of all tree stumps, bushes, jungles, roots, brushwood, rubbish of all kinds, loose stones and all other objectionable materials. The ownership of all the useful materials so removed from clearing site and or excavation shall rest with the department. The contractor shall have to remove all the stumps and roots of trees for which no additional payment will be made. The roots of the trees shall be grubbed to full depth. The contractor shall dispose off all such materials within 1 km. or as directed by the Engineer-in-Charge. All operations in connection with clearance of jungle and bushes shall be subject to provision of forest acts and rules.
- (b) No separate payment will be made to the contractor for the complying the requirements of this paragraph and all cost shall be deemed to have been included in the rates quoted in schedule for the items of excavation.

##### **2 RECORDING OF CROSS SECTION**

After clearing the site the area is to be stripped of objectionable materials after which the initial cross sections shall be taken at every 30 m interval or closer depending on nature of the ground upto sufficient distance outside the limit if work. Levels on these cross sections shall be taken at 5 m. or closer intervals as directed by the Engineer-in-Charge and recorded in the field and level books in the presence of the contractor or his authorized agent shall sign the field work/level book in the token of acceptance. These c.s. shall form the basis of all future

measurement and payment. The original c.s. duly signed by contractor and the Engineer in charge shall be preserved. Such dimension shall be measured to the nearest 0.01 M. any dimension greater than 25 mm. shall be measured to 0.01 M. Area shall be computed to 0.01 M<sup>2</sup>, volume shall be computed to 0.01 M<sup>3</sup>.

## **FOUNDATION PREPARATION**

### **1 SOIL FOUNDATION**

Soil foundation under the seat of road shall be scarified and loosened by means of a plough, flipper or other means to a depth of about 15 cm .to 20 cm .to the satisfaction of the Engineer-in-Charge. Roots and other debris turned up during scarifying shall be removed from entire foundation area for the fill. Before placing of fill materials, the stripped slat of the road is to be initially compacted. The first few layers of fill for the road shall be of depth of 10 cm to 15 cm and shall be carefully placed, ensuring uniform compaction and a satisfactory intimate bond between the foundation soil and fill materials. Heavy rubber type rollers or vibratory rollers may be used for compaction because they will follow the irregular surface and not bridge over small low areas as other type of rolling equipments will do. Power Road Rollers shall be used for compaction of impervious soil and preferably vibratory type roller shall be used for compaction of all other soil and rock. Separate payment shall not be made for preparation of foundation as above and it shall be deemed to have been included in the unit rate quoted for respective item of road.

### **2 SAND FOUNDATION**

Sand met with in foundation shall be tested for it's lateral relative density. In reaches where the relative density is less then 70% the foundation sand shall be compacted by any of the approved methods to obtain a minimum relative density of 70%. Until the foundation has been tested and the relative density found to exceed 70%, fill shall not be allowed to be placed. This is necessary to minimize the effect of any structural readjustment in a loose foundation.

## **BORROW AREA**

### **1 GENERAL**

All materials required for the construction of road shall be obtained from borrow areas duly approved by the Engineer-in-Charge in consultation with quality control unit. The contractor has to arrange borrow area for necessary testing and approval of Engineer-in-Charge to borrow sand & moorum at his own cost and responsibility. No compensation whatsoever for change in limits and locations of the borrow areas and depth of cut for getting suitable road materials shall be paid to the contractor. No excavation is permitted within a distance of ten times the height of road from the outer toe. Borrow pits shall be operated so as not to impair the usefulness or mar, the appearance of any part of the work or any other property. The

surface of wasted materials shall be left in a reasonably level and even condition. Adequate lighting arrangement should be provided by the contractor at the borrow area if required.

**2 PREPARATION OF BORROW AREA**

All areas required for borrowing sand for road shall be cleared of all tree stumps, roots, bushes, rubbish and other objectionable materials. Particular care shall be taken to exclude all organic matter from the materials to be placed in the approach road. All cleared organic materials shall be burnt to ashes or disposed off as directed. The cleared areas shall be maintained free of vegetable growth during the progress of the work. No payment shall be admissible for preparation of the borrow areas indicated above as this is deemed to have been included in unit bid price.

**3 STRIPPING OF BORROW AREAS**

Borrow areas shall be stripped of top soil, and any other objectionable materials to the required depth I as directed by the Engineer-in-Charge. The work may be done manually or with suitable machine. Stripping operations shall be limited only to designated borrow areas. Materials from stripping shall be disposed of in exhausted borrow areas or in the approved adjacent areas as directed. No extra payment shall be admissible for stripping the borrow areas as this is deemed to have been included in the unit bid price.

**HAUL ROADS AND APPROACH ROADS**

Construction and maintenance of approach roads and haulage roads will be the responsibility of the contractor. The department will have full left of way to those roads for inspection purposes. Proper road sign as directed have to be provided for safety. For haulage of road materials, the contractor shall construct ramps and haulage and of sufficient width along the shortest but most practical route and shall maintain and illuminate them to a satisfactory manner. Watering of the haul road shall be done by the contractor as often as necessary to prevent raising of dust, formation of cuts and consequent deterioration of the surface. Whenever service roads meant for public thorough fare traverse through or run close to the borrow areas, the contractor shall direct his excavation and haulage operation in such manner as to ensure uninterrupted use of the service road and safety to the public. At the haul road and the service road crossing, the contractor shall install necessary check gates and road signs. No extra payment is admissible as this is deemed to have been included in the unit bid price for the earth work item being contingent to the main work.

**WEATHER CONDITIONS**

Road materials shall be placed only when the weather conditions are satisfactory to permit accurate control of the moisture content in the road materials. Before closing work on road, the top surface shall be graded and rolled with a smooth wheeled roller to facilitate run off. Prior to resuming work, the top surface shall be scarified and moistened or allowed to dry as necessary and approved by the Engineer-in-Charge for resumption. The contractor shall provide suitable protection works to protect the slope from erosion due to rainwater. No payment whatsoever shall be made for providing such protection work and rectifying of monsoon damages.

## **WATERING**

- (i) Adequate watering to the sand fills it to be done to facilitate proper compaction. Similarly water content to moorum is to be controlled for proper compaction. No compensation will be made to the contractor due to held up of work for rain, fog and moisture content in the working process.

## **COMPACTION**

### **1 GENERAL**

- (a) Having decided on the filling materials to be used, standard compaction test shall be made on the materials proposed for road to indicate broadly which are the most suitable type of equipment to be used and the moisture content at which compaction should be undertaken and also to determine the effects of soil moisture content, thickness of layer and number of passes.
- (b) Having decided on the thickness of layer and range of moisture contents, tests should be made with different type of equipment available and the required number of passes should also be determined.
- (a) In all this work, the state of compaction should be measured in terms of dry density.
- (b) Density tests if felt necessary by Engineer-in-Charge shall be made after rolling in that case. Standard proctor density test shall be carried out at regular intervals to account for variations in the borrow area materials as well as that in situ excavated materials.
- (c) The contractor shall supply all materials labour machinery and equipment at his cost for the work.
- (d) No extra payment shall be made for these operations as this shall be deemed to have been included in the price bid in schedule of Quantities for the respective item of work.

## **ROLLING**

When each layer of materials has been prepared so as to have the proper moisture, content uniformly distributed throughout the materials it shall be compacted by passing the vibrating roller or P. R .R .The exact number of passes for each layer to obtain specified density shall be designed by the field laboratory after necessary test, the layer shall be compacted in strips over tapping not less than 0.6 m. Rolling shall commence at edges and progress towards centre longitudinally. The rollers of loaded vehicle shall travel in a direction parallel to the axis of the road. Turns shall be made carefully to ensure uniform compaction. Rollers shall always be pulled. Density tests shall be made after rolling and dry density attained shall satisfy the compaction standards specified in relevant I.S. Codes.

## **COMPACTION OF COHESIONLESS MATERIALS**

Where compaction of cohesion less free draining materials such as sand and gravel is required, the materials shall be deposited in horizontal layers and compacted to the relative density specified. The excavation and placing operations shall be such that the materials when compacted shall be blended sufficiently to secure the highest practicable unit weight and best stability. Water shall be added to the materials as may be required to obtain the specified density by method of compaction being used.

The thickness of the horizontal layers after compaction shall not be more than 10 cm, if compaction is performed by tampers and more than 15cm, if by rollers.

## **DRESSING SLOPES**

The slopes of road shall be neatly dressed to lines and grade as shown on the drawing as the placing of fill progress, compaction shall extend over the full width of the road and materials in slopes shall be compacted as for the rest of the road. To ensure proper compaction of the edges, the cross section of the fill during construction shall be kept suitable wider as directed by the Engineer-in-Charge and cross section shall be dressed to the designed requirement after compaction for which no extra payment shall be made as it is deemed to have been included in unit bid price for item of schedule of Quantities. Materials used to fill depression shall be of same type as used in the road and shall be thoroughly compacted and bonded to the original surface. Slopes shall be maintained until final completion and acceptance. Any material that is lost by rains, weathering or other causes shall be replaced at the cost of the contractor till completion of the works and taking over by the department.

## **SETTLEMENT ALLOWANCES**

- (i) In the fill road, settlement allowances of 2% will be provided. Accordingly extra height shall be provided but payment for design height will be made. The base width of the road will not be increased to maintain the design slopes indicated in the drawing for the additional height as settlement allowances, but the following procedure will be adopted, settlement allowances will be calculated at various levels where the slopes is to be changed and the elevations including settlement allowances will be derived keeping the road widths of the designed levels unchanged. The edges of road at the increased elevations (including settlement) when joined with the starting point where the slope has changed earlier bellow, shall give the slope to be adopted for constructions.
- (ii) If the road is raised in more than one season, provision for settlement shall be made in the last season's construction as described above.

## **MEASUREMENT AND PAYMENT**

- (a) All works shall be measured by levels.
- (b) For payments the level books, field books, the cross section sheets and calculations sheets shall be treated as adjuncts to the measurement books.
- (c) All linear measurements shall be in meters, correct to 0.01 meters, area worked out in square meter correct to 0.01 m<sup>2</sup> and volume work-out in cubic meters correct to 0.01 m<sup>3</sup>.
- (d) The quantities between the levels taken after stripping and cross sectional levels taken after construction of consolidated road with the available useful excavation soils. It shall be clearly understood that construction of road to extra width as specified and extra height formed for settlement allowance as specified earlier will not include for payment. The measurement will be limited to within design section.
- (e) Final measurement and levels shall be taken at the cross sections of the completed compacted bank design section after the slopes dressed to ensure that work is completed as shown in the drawing plus settlement allowances. The measurements for computation of quantity shall not include the extra section provided for compaction of sand fill upto lines of finished slope and for settlement allowances.

## **RATE FOR PAYMENT**

The rate for Construction of road under item provides all costs for labour, materials, tools and plants, machinery, excavation, transportation and incidental operations required for carrying out and

completing the item of work in accordance with the specification, drawing and as directed by the Engineer-in-Charge including (i) Site clearance (ii) Setting out works (iii) Marking out, providing and forming model section, locks spitting, strings and stakes as may be considered necessary by the Engineer-in-Charge to guide the contractor in road construction (iv) compacting the original ground including preparation of seat under road (v) Scarifying and benching etc.(vi) Clearing trees stumps and bushes, stripping of the borrow area upto required depth (vii) Maintaining borrow area free from vegetation growth, drainage arrangement and moisture control including watering (viii) Loading, conveyance from designated borrow area, unloading and spreading of suitable materials including rehandling (ix) Construction and maintenance of approach roads and haul roads (x) Cutting and trimming as specified in dressing of slopes (xi) Restricted working near sites of structures (xii) Settlement allowance (xiii) Spreading in thinner layers at required places (xiv) Compaction with suitable compactors (xv) Removal of materials like bushes, roots, sods, other perishable materials and pebbles etc. from the fill materials (xvi) Providing labour and testing charge for testing of samples (xvii) All drainage and dewatering as required (xviii) The section of all work to be maintained in good order during execution and also in rainy season (xix) All safety measures.

## **SCOPE OF WORK**

This specification covers items for construction of road work starting from sub-base preparation to pre-coated seal coat over premix asphalt carpeting including earth work in excavation or trimming for laying sub base, preparation of sub-base with moorum and sand mix laying and compacting I.R.C. Gr .II (63mm to 45mm. size) and I.R.C. Gr. III (53mm to 22.4mm size) metaling with hard granite hand broken metal premix; asphalt carpeting and precoated seal coat. The work covers providing all materials, labour, conveyance of materials with all leads, lifts and delifts, stacking at site, spreading, rolling, watering including royalty and all taxes.

## **GENERAL**

- (i) All works performed shall conform to lines, grade, cross sections, levels and dimensions shown in the drawing with necessary super elevation and extra width at curves for roads and as directed by the Engineer-in-Charge.
- (ii) Proper care shall be taken to avoid any interference with or damage to works of other discipline such as water supply, sewerage, electricity etc.
- (iii) The Contractor shall submit sequence of operation which he proposes to follow to the Engineer- in-Charge and shall obtain approval to it prior to commencing work and shall adhere to the agreed sequence after modification if any by the Engineer-in-Charge.
- (iv) The methods and plants and equipments to be used by Contractor is subject to approval of Engineer-in-Charge .
- (v) Sign boards for construction activities, overtaking signals, diversion of road etc. is to be displayed by Contractor at his own cost.
- (vi) The Contractor shall at all time carry out work in a manner creating least interference to the traffic during execution. The Contractor shall provide and maintain during execution a

passage for traffic either along or as part of existing way under construction or a separate diversion road at his own cost.

- (vii) Quality of all materials should be approved by Engineer-in-Charge prior to collection at site.
- (viii) Construction traffic shall not be allowed to use the newly prepared surface without prior permission from Engineer-in-Charge. Any damage arising out of such use shall however be made good by the Contractor at his own cost.
- (ix) All measurement a 00 ( should be rounded to next higher digit) computations unless otherwise indicated shall be carried out to the following limit
  - (i) Length and breadth –10 mm .
  - (ii) Height, depth or thickness of earthwork, Sub base and base course-5mm.
  - (iii) Areas - 0.01 sqm.
  - (iv) Cubic content - 0.01 cum.
- (x) Materials found inferior and rejected shall be removed from site immediately by the Contractor at his own cost.
- (xi) Works rejected by the Engineer-in-Charge on ground of poor quality or workmanship shall be dismantled and redone by the Contractor at his own cost.
- (xii) Complete stacking of materials like sand, moorum, H.G. chips: as per requirement shall be carried out in 2Km. length before spreading, The collection shall always commence at one end and be carried continuously towards the other unless the Engineer-in-Charge directs otherwise.
- (xiii) Till utilization, the Contractor will be responsible to protect the materials collected at the work site at his own cost.
- (xiv) The unit rates for different items of work shall be for payment in full for completing the work to the requirement of specification including full compensation for all the operations detailed in relevant section of specification and in schedule. The rates are considered for finished work covering all labour, tools, equipment, wastage, Temporary works, hire and running maintenance of plant and equipments, watch and ward, overhead charges and profit as well as general liabilities, obligations and risk arising out of the contract for the work.

#### **EXCAVATION (OR) TRIMMING FOR LAYING SUB-GRADE**

- (i) The road or surface to the full width of the pavement is to be excavated or trimmed to designed level for laying the sub-grade.
- (ii) The excavated material to be disposed off by laying on the berms or slope of road finished smooth or as directed by Engineer-in-Charge.
- (iii) Measurement for payment shall be made on cubic meter basis. The volume will be measured by level section limited to designed sections, lines and grade.

#### **MATERIALS**

##### **1 MOORUM**

The moorum shall have plasticity index not less than 6 as determined in accordance with I.S.

2720 (part v) .It shall be free from all rubbish, dust and organic materials as well as clods of clay / black cotton soil. The moorum should be granular and gritty.

## **2 CEMENT**

- a) Ordinary Portland cement (OPC), Portland Pozzolana cement (PPC) shall be procured in bulk by the contractor. The contractor shall not be allowed to use bag cement, unless specifically so permitted by the Engineer-in-charge.
- b) Only Ordinary Portland cement (OPC) shall be used for controlled concrete and other RCC construction. Pozzolana Portland Cement (PPC) may be allowed in mass concrete etc.
- c) The Contractor shall create a suitable and adequate infrastructures for procuring, handling, storing and conveying bulk cement to batching plant at site, with advance planning of work to be done during next one month.
- d) Immediately upon receipt at the site of the work, cement shall be stored separately in dry, water tight and properly ventilated structures at the cost of the contractor. All storage facilities shall be subject to approval and shall be such as to permit easy access for inspection and identification. The contractor shall produce test certificate of the manufacturer for every 500 tons of receipt of cement or as approved by Engineer-in-charge.
- e) Sampling & testing shall be done by the laboratory of the Dept. No cement shall be used until clearance has been given by Engineer-in-charge that the test result are satisfactory. Cement older than 90 days shall not be used unless the test result satisfy the minimum strength requirements. For physical and chemical requirements, ordinary Portland cement and Portland pozzolana cement to conform IS: 269-1976 and IS: 1489-1976 respectively. Actual cement level required for the concrete shall be determined by mix-design.

## **3 SAND**

Sand shall consist of hard, dense, durable and uncoated silicious gritty materials. Sand to be used shall be natural as obtained from river bed from specified quarries. It shall be free from all rubbish, dust and organic materials as well as clods of earth loam and other deleterious substances.

### **Fine Aggregates**

General aggregates shall conform to IS: 383-1970 or its latest version. Sand to be used shall be natural as obtained from the river bed from specified quarries. The contractor may obtain sand from different sourced which shall meet requirement of specification. Fine aggregates will be tested for their gradation specific gravity, water absorption, fineness modulus, soundness, petrography analysis, deleterious constituents and alkali aggregate reactivity to assess suitability for use.

### **QUALITY**

- a) Sand shall consist of hard, dense durable and uncoated silicious gritty materials. It shall be free from injurious amount of dust, lumps, soft and flaky particles, shale, alkali, organic matter, loam and other deleterious substances. Sand shall be washed if necessary to remove all vegetations and other foreign matter. The cost of washing and screening shall be borne by the Contractor. The maximum percentage of each of the deleterious substance in sand as delivered to the mixer shall not exceed the following values.

*Material Passing Percentage by weight*

75-Micron IS Sieve 3.0

Clay lumps 1.0

Cinders and Clinkers 0.5

Mica 2.0

Total of all deleterious substances Including alkali, mica coated grains, soft and flaky particles, loamsetc. 5.0

a) Sand shall be free from injurious amount of organic impurities. Sand that are producing a colour (obtained by dissolving 9 grams of chemically pure ferric chloride and 1 gram of CP cobalt chloride in 100 ml of water to which one-third ml of hydro-chloric acid has been added) darker than the standard in the test (Organic test for organic impurities shall be rejected).

**GRADING**

a) Sand shall be well graded so as to impart good workability and good finishing. Sieve analysis of natural sand shall conform to the following limits of gradation. *IS Sieve Percentage of weight passing on Sieve*

4.75 mm 100

2.36 mm 90-100

1.18 mm 70-100

600 micron 40-100

300 micron 5-70

150 micron 0-15

b) A sand whose grading falls outside the specified limits due to excess or deficiency of coarse or fine particles may be processed to comply with the standard by screening through a suitably sized sieve and/or blending with required quantities of suitable sizes of sand particles. Based on test results and in the light of practical experience with the use of local materials, deviation in grading of sand may be considered by the Engineer-in-charge.

**FINENESS MODULUS**

a) Sand should have a fineness modulus between 2.1 to 3.0 subject to the gradation specified in the preceding paragraphs. b) The modulus shall be computed by adding cumulative percentage of sand retained on the IS Sieves 4.75 mm, 2.36 mm, 1.18mm, 600 micron, 300 micron, 150 micron and dividing the sum by 100. Gradation of sand shall be so controlled that the fineness modulus of at least 9 out of 10 consecutive test samples of finished sand shall not vary by more than 0.10 from the average. Sand having any deviation from the specified range or gradation and fineness modulus shall not be permitted to be used in work without the written permission of the Engineer-in-charge.

**SPECIFIC GRAVITY – 2.6 minimum.**

**BULKAGE – less than 20%**

**STORAGE**

All sand shall be stored on the site of work in such a manner as to prevent intrusion of foreign matter.

#### 4 STONE AGGREGATE

##### METAL

- (a) The hard granite crusher broken stone metal shall be obtained from rock excavation if available or quarries as approved by the Engineer-in-Charge prior to collection. The metal shall be obtained from hard, tough, sound, durable stone of close texture as is locally available and reasonably free from decay and weathering. Pieces of the stone shall be angular and roughly cubical in shape, round, elongated or flaky materials shall be rejected. No round or along pebbles or angular chips, longer or smaller than the specified size shall be allowed. The size of the metal shall be 40mm to 90mm for I.R.C. Grade-I and 45mm to 63mm, for I.R.C. Grade-II and it shall be machine crushed.
- (b) Samples metals, collected from the approved quarries shall be get tested by the Contractor at his cost in the laboratory. The test results shall conform to the standard requirement laid down for metal to be used for this work.
- (c) The physical requirement for standard size metal shall conform to the test results in the Table in next page.

Type of construction	Test	IS for test method	Requirement
Base	(i) Los Angels abrasion value	IS: 2386 (Part iv)	50% Maximum
	(ii) Aggregate impact value	IS: 2386 (Part iv) or IS: 5640	40% Maximum
	(iii) Flakiness	IS: 2386 (Part-I)	15% Maximum.
	(iv) Water absorption	IS: 2386 (Part iii)	2% Maximum.

(d) Grading requirement of coarse aggregates :

The coarse aggregate shall conform to one of the gradings as given in table below provided, however the use of grading No. I shall be restricted to sub-base coarse only.

**Table: Grading requirement of coarse aggregates.**

Grading No.	Size Range.	Sieve Designation	Percentage by weight passing
I.R.C.-I, Metal	90 mm to 45 mm	125 mm	100
		90 mm	90-100
		63 mm	25-60
		40 mm	0-5
I.R.C.-II, Metal	63 mm to 45 mm	90 mm	100
		63 mm	90-100
		40 mm	25-60
		20 mm	0-10
I.R.C.-III, Metal	53 mm to 22.4 mm	53mm	100
		26.50mm	55-75
		4.75 mm	10-30
		0.0075mm	0-5

**CHIPS**

(a) Stone chips shall consist of regular fragments of clean hard, tough and durable rock of uniform quality throughout by crushing granite rock, and shall be free of elongated and flaky pieces, soft and disintegrated materials, and vegetable or deleterious matter. They shall satisfy the physical requirements set-forth as under.

Test	IS for Test Method	Requirements.
(i) Los Angels Abrasion value	IS:2386 (Part-IV)	35% Maximum
(ii) Aggregate impact value	-do-	30% Maximum
(iii) Flakiness index	IS:2385 (Part-I)	30% Maximum
(iv) Stripping value	IS:624	25% Maximum
(v) Water Absorption	IS:3386 (Part-III)	2% Maximum.

(b) Size of the stone chips shall be as under :

- (i) For premix carpet 13.2mm to 5.6mm size: Passing through proper sieve and retained on 10 mm sieve.
- (ii) For precoated seal coat 6mm and downgraded size: passing 10mm sieve and retained on 2.36mm. sieve.

(c) Samples of stone chips collected from the approved quarries shall be got tested by the Contractor at his cost in laboratory. The test results shall confirm to the standard requirement as laid down herein.

- (i) Control on quality of material will be exercised by the Engineer-in-Charge by carrying out the following tests at frequencies shown against each.

Type of construction material	Test	Frequency
Chips for carpet and seal coat.	i) Aggregate impact value	One test per 100 M <sup>3</sup> of aggregate
	i) Flakiness index of aggregate.	-do-
	ii) Stripping value and water absorption of aggregates.	Initially, one set of 3 representative specimens for each source of supply subsequently when warranted by changes in the quality of aggregates.
	iii) Grading of aggregates	One test for 100 m <sup>3</sup> of aggregates.

**BITUMEN**

Bitumen of 80/100 grade conforming to IS:73,217 or 454 as applicable of other approved cut back approved by the Engineer-in-Charge, in writing shall be utilized in the work. Procurement of the bitumen will be made by the Contractor his own cost from reputed manufacturers on approval by the Engineer-in-Charge. The contractor is to produce test certificate to be issued by manufacturer for each consignment separately.

## **CONSTRUCTION PROCEDURE**

### **1 SUB-BASE BELOW PAVEMENT**

- (i) Moorum and sand stacked separately shall be conveyed and mixed properly to make an admixture of moorum and sand in proportion as per direction of Engineer-in-charge.
- (ii) The formation after excavation or trimming shall be dressed to required camber and grade.
- (iii) The admixture of moorum shall be spread in subbase and also side shoulders in layers not exceeding 15cm. in thickness and should be adequately watered.
- (iv) Immediately following spreading of spreading of admixture moorum rolling will be started with three wheeled roller of 8 to 10 tones capacity or equivalent vibratory roller. The rolling shall begin from edges firmly compacted and then progress gradually from edges to centre, parallel to the centre line of the road and over lapping uniformly each preceding rear wheel track by one half width and shall continue until the entire area of the course has been rolled by the rear wheel. In case of superlevated portions rolling shall proceed from inner edge to the outer edge. Rolling to continue till the admixture of moorum is thoroughly keyed. During rolling sprinkling of water is to be done as required for a dense compacted mix layer .
- (v) The rolled surface to be checked transversely and longitudinally and any irregularities, ruts and soft yielding places be corrected by loosening surface, adding or removing amount of admixture moorum and rolling entire surface to conform desired grade and camber of 1 in 50 (not flatter than 1 in 72).

### **2 I.R.C. GRADE-I AND I.R.C. GRADE-III METALING**

#### **SPREADING OF COARSE AGGREGATE**

- i) The quality and grading of I.R.C. Grade-I metal (size 90mm to 45mm) and I.R.C. Grade-II metal (size 45mm to 63mm .) shall satisfy criteria described under sub-head criteria "materials" (Chapter 11.6.3).
- ii) Stacking for Gr.-II shall be done after the spreading of Gr.-I metal.
- iii) The surface to receive I.R.C. Gr-I or Gr.-II water bound macadam course (metaling) shall be made free from dust and other extraneous material.
- iv) The respective grade metals shall be spread uniformly to specified nominal thickness of 11.5cm. and 10 cm for I.R.C. Grade-1 and I.R.C Grade-III metaling respectively or as directed by Engineer- in-charge.
- v) The spreading shall be done from stacks along the side of the roadways or approved stock yards. In no case shall aggregates be dumped in heaps directly on the surface prepared for the metaling nor shall hauling over un compacted or partially completed base be permitted. No segregation of large or fine particles shall be allowed.  
  
The surface of the aggregates shall be carefully checked with Templates and all high or low spots remedied by removing or adding aggregates as may be required by hand packing the same to proper grade and camber.
- (vi) The bunds of earth or moorum one on either side shall be made along the outer edge of metaling prior to or simultaneously with spreading of metal. In addition where over required turf edging are to be provided. These bunds and turf edging are required to prevent loose

metal from spreading out beyond width of road to be metaled.

No extra payment will be made for the bunding or turf edging as the same are deemed to be / included in the unit rate of respective items.

- (vii) The course aggregate shall normally be spread more than 3 days in advance of the subsequent / operation.
- (viii) Spreading of metal shall proceed only 200m. in advance of rolling operation.

### **CONSOLIDATION**

- (a) Immediately following the spreading of the coarse aggregates, rolling shall be started with three wheeled power roller of 8 to 10 tonne capacity or equivalent vibratory roller. The weight of the roller shall depend upon the type of the aggregate and shall be as indicated by Engineer-in-charge.
- (b) Except on super-elevated portions where the rolling shall proceed from inner edge to outer rolling shall begin from the edges gradually progressing towards the centre. First the edge/edges shall be compacted with roller moving forward and backward. The roller shall then move inwards parallel to the centre line of the road, in successive passes uniformly lapping preceding tracks by at least one half wheel width.
- (c) Rolling shall continue until the aggregate is thoroughly keyed and the creeping of the aggregate ahead of the roller is no longer visible. During, rolling slight sprinkling of water may be done, if necessary. Rolling shall not be done when the sub-grade is soft or yielding or when it causes a wave like motion in the sub-grade or sub-base course.
- (d) The rolled surface shall be checked transversely and longitudinally with Templates and any irregularities corrected by loosening the surface, addition or removing necessary amounts of aggregates and re rolling till the entire surface conforms to desired camber and grade. In no case shall use of screenings be permitted to make up depression.
- (e) Moorum as blinding material shall be applied, successively in two or more thin layers at a slow and uniform rate. After each application, the surface shall be copiously sprinkled with water, the resulting slurry swept in with hand brooms or mechanical brooms to fill the voids properly, and rolled, during which water shall be applied to the wheels of the rollers, if necessary to wash down the blinding materials sticking to them. These operations shall continue until the resulting slurry after filling the voids, forms a wave ahead of the wheels of the moving roller.
- (f) After final compaction of water bound macadam course, the road shall be allowed to dry overnight. Next morning hungry spots shall be filled with screenings or binding materials as directed, lightly sprinkled with water, if necessary & rolled. No traffic shall be allowed on the road until the macadam has set. The Engineer-in-charge shall have the discretion to stop hauling traffic from using the completed water bound macadam course if in his opinion it would cause damage to the surface.
- (g) Material which crushed excessively during compaction or becomes segregated shall be removed & replaced with suitable aggregate.
- (h) It shall be ensured that shoulders are built up simultaneously along with water bound macadam courses.

## CONSUMPTION OF MATERIALS

Consumption of material for specified thickness of pavement in case of both I.R.C. Gr.I and I.R.C. Gr. III metaling shall be as follows:

	<u>I.R.C. Gr.I</u>	<u>I.R.C. Gr.III</u>
Over all (Nominal) thickness of layer laid	121 mm.	100 mm.
Compacted thickness	100 mm	75mm.
Consumption of metal	0.121 cum/sqm	0.100 cum/sqm
Consumption of moorum as blinding	0.030 cum/sqm	0.022cum/sqm material.

Note : Quantity of metal and moorum is after deduction of void from stacked measurement.

### Surface Finish and Quality Control.

The surface finish of construction shall conform to the requirements of Clause 902. All materials shall comply with the requirements of the relevant provisions in Section 900 of the Specifications.

### Base and surface courses (Bituminous)

### Section 500

#### Final Surfacing.

The built-up-spray-grout shall be provided with final surfacing within a maximum of forty-eight hours. If there is to be any delay, the course shall be covered by a seal coat to the requirement of Clause 513 before it is open to traffic. Where the seal coat is required as a result of the selected method of performing this operation, then it shall be considered incidental to the work and shall not be paid for separately.

#### Arrangements for Traffic.

During the period of construction , arrangements for traffic shall be made in accordance with the provisions of Clause 112 of the Ministry's Specification for Road and Bridge works (third revision) 1995.

#### Measurement for payment.

Built-up spray grout shall be measured as finished work in square metres.

#### Rate

The contract unit rate for built-up spray grout shall be payment in full for carrying out the required operations as specified. The rate shall include for but not necessarily by limited to the components listed in Clause 50 L8.8.2(i) to (xi).

### 3. SHOULDER CONSTRUCTION

(i) The shoulders or berms on either side of the pavement over the embankment to be constructed with rolled moorum layer in conformity with the lines, grades and cross sections as per approved drawing and as directed by the Engineer-in-charge.

(ii) Moorum shall be conveyed from the road side heaps or from stockyard and spread on the prepared base to lines and grade.

(iii) Rolling will be done with 8 to 10 tonne capacity three wheeled rollers as per similar to procedure laid for sub-base.

## **ROAD DIVERSION**

- (a) The Contractor shall Construct and maintain the road diversion for the traffic with necessary sign boards working signal during construction period as approved by the Engineer-in-charge at his own cost.
- (b) The Contractor shall take all necessary measures for the safety of traffic during construction and provide, direct and maintain such barricades including sign, marking, light and flagmen as may be required by the Engineer-in-charge for the information and protection of traffic approaching and passing through the section of the road or highway under construction. Before taking up any construction, phased programme for the Control of traffic on the road or highway shall be drawn up in consultation with the Engineer-in-charge.
- (c) The barricades erected on either side of the portion of the carriage way closed to traffic shall be strong to resist violation and painted with alternate black and white strips. Red lantern or warning lights of similar type shall be mounted on the barricades at night and kept there through out from sunset to sunrise. At the points where traffic is to deviate from its normal path, the channel for traffic shall be clearly marked with the aid of pavement marking and painted drums are to be kept throughout the channel. At night the passage shall be lighted with lanterns or other suitable light sources.
- (d) One way traffic operation shall be established whenever the traffic is to be passed of the carriage way inadequate for two lane traffic. This shall be done with the help of flagmen kept positioned on opposite sides during all hours. For regulation of traffic, the flagmen shall be equipped with red and green flags and lanterns lights on both sides, suitable regulatory/warning signs shall be installed for the guidance for the road users on each approach at least two sign shall be put up one close to the point where transition of carriage way begins and the other 120 meters away. The sign shall be of approved design and of reflector type, if so directed.

## **MEASUREMENT AND PAYMENT**

- (i) Providing and stacking moorum, H.G. metal (I.R.C. Gr.I and III), Moorum, metal and Chips shall be stacked in standard box heaps of 1.5 M.x1 .5M.x0.5M.to be measured as 1 Cum.Sand shall be stacked in regular stacks or box heaps of 1.5Mx 1.5Mx 0.5M as per direction of engineer-in-charge.

The unit rate for respective items includes excavating, collecting procurement, conveying to work site including loading, unloading, stacking the same at approved stack yard beyond trafficable berm in regular box heaps or stacks as directed by the Engineer-in-charge with all leads, lifts and delifts, including royalty, all taxes and incidental charges like watch and ward till utilization.

- (ii) Sub-base preparation with moorum

Measurement for conveying from stacks, laying moorum and watering and rolling for sub-base below pavement shall be based on cubic meter content of moorum based on pre measurement of items as actually utilized in the work after deduction of void.

The rate shall include Labour and T & P required for conveying moorum from stacks measured previously collection paid separately) spreading the moorum to required thickness, watering, rolling, turving with all leads, lifts and delifts, hire and running charges of P.R.R., cost, conveyance of turf and water including royalty and all other taxes, incidental charges etc .complete for finished item of work to lines and grade as per drawing, specification and as directed by the Engineer-in-charge.

- (iii) R .C Grade-I and Gr. III metaling courses will be based on cubic meter content of metals utilized in work after deduction of void from stacked measurement. Volume of moorum used as binding material will not be added to the cubic meter content of I.R.C.Gr.I or Gr. III metaling for payment. The rates shall be for finished items of work to lines and grade (excluding cost of H.G. stone, metal and moorum measured and paid separately) including labour and T & P. required for conveying from stacks and spreading hard granite crusher broken metal to specific thickness, packing voids with small size metals uniformly, hand packing to proper camber, conveying from stacks and spreading of moorum of specified grade and quantity over the metal surface to fill of interstices, watering and consolidation with

P.R.R. including hire and running charges of P.R.R. and other equipments, turf edging, cost and conveyance of turf and water with all leads, lifts and delifts including royalty and all other taxes, incidental charges etc. Complete as per specification and as directed by the Engineer-in-charge.

**(iv) Shoulder construction**

Measurement for conveying moorum from stacks and spreading to required thickness, watering and rolling shall be based on cubic meter content of moorum, after deduction of void, actually utilized in the work.

The rate shall be for finished items of work including labour charges with all leads, lifts, delifts, hire and running charges of P.R.R. and other equipments, turf edging, cost and conveyance of turf and water but excluding cost of moorum measured and paid separately.

## **5. SPECIFICATION FOR EARTH WORK IN THE CONSTRUCTION OF EARTH EMBANKMENT FOR ROAD WORK:**

### **5.1 SCOPE**

The specification shall apply to the construction of embankment & of miscellaneous backfills with materials obtained either from excavation for road construction, borrow-pits or either selected borrow areas. All embankment shall be constructed in accordance with the specifications & in conformity with the alignment level, cross sections & dimensions shown in the plans or as started by the Engineer-in-Charge.

**5.1.1 MATERIAL:** The scope of these specifications are restricted to soil alone, being the construction material. The soil used for embankments shall be free from stumps, tree roots, rubbish or other material likely to deteriorate or effect the stability of the embankment. Only materials considered suitable by the Engineer-in-Charge shall be utilized for the construction & that considered unsuitable shall be disposed of as directed by him.

**5.1.2** For the purpose of these specification soil will be taken to include gravel or moorum.

**5.1.3** The selection of the materials to be used in the construction of embankment shall be made as per the directions of the Engineer-in-Charge according to soil survey & laboratory investigation conducted by him.

**5.1.4** Quality control test such as gradation, P.I. Standard proctor test, deleterious constituents, natural M.C etc. shall be performed as directed by the Engineer-in-Charge & no extra payment will made in this regard.

### **6.1 EXCAVATION OF BORROW PITS:**

**6.1.1** As far as possible no borrow pits should be dug on road land. Before deciding to dig borrow pits on road land, earth for the embankment should be obtained.

(i) from cutting of nearby sections of the road.

(ii) from excavation improving sight distances at nearby curves.

(iii) by sectioning an adjacent bullah or waterway where necessary

(iv) by excavating cuts to lead drainage water away form the road

(v) by excavating side drains & catch water drains

(vi) from waste land outside the road land

(vii) from bumps above the general ground level with the road land

(viii) by excavating tanks

(ix) from land acquired temporarily outside road land

(x) from soil mounds resulting form the digging of well & borrowings from fields in the vicinity of the road

**6.1.2** Borrow pits should be rectangular in shape with on side parallel to the central line or the road. If no road land, they could be dug as near the road boundary as possible.

**6.1.3** No borrow pits should be dug within 6 mtr. (16 ft.) of the final section of the road embankment, after making due allowance for future development.

- 6.1.4 Borrow pits should not be dug continuously. Ridges of not less than 8 mtr. (25 ft.) width should be left at intervals not exceeding 30 mtr. (100 ft.) Small drains should be cut through the ridges, in necessary to facilitate drainage.
- 6.1.5 When it becomes necessary to borrow earth from temporarily acquired cultivatable lands, the depth of borrow pits should not exceed 45cm. (1.5 ft.). The top soil to a depth of 15cm (6") should be stripped & stacked a side. Thereafter soil may be dug/cut to a further depth not exceeding 30 cm. (12") & used in forming the embankment. The top soil should then be spread back on the land. It is most important to adopt this practice when soil borrowed is from rich cultivatable land.

## **6.2 CONSTRUCTION PRELIMINARY OBSERVATIONS:**

- 6.2.1 **Clearing & Grubbing:** Prior to the commencement to earth work the site shall be cleared of construction, including building, fences, abandon drainage structures & vegetation such as tree, roots undergrowth, grass, rubbish etc. except where it may be desirable to retain the vegetation for appearance shade or other reasons. Complete clearance shall be carried out within the actual construction limits.

All trees & shrubs which are not expected to interfere with the construction & use of the highway should be preserved. Cost of removal or ordinary vegetation & minor jungle growth & disposal thereof as directed by the Engineer-in-Charge shall be included in the tender rate & shall not be paid for as extra.

- 6.2.2 Three stumps should be not extend more than 1ft. above the original ground nor should they be closer than 2 ft. to any sub-grade shoulder or slope surface. On areas to be cleared beyond the embankment & earthwork lines, stumps must be cut down below ground level so that appearance may not by unsightly.
- 6.2.3 The removal bush & stumps shall in cases be cleared away to waste lands preferably burnt no locations away from the road side. Materials possessing any salvage value should be stacked as directed by the Engineer-in-Charge.
- 6.2.4 Care shall be taken to see that unsuitable waste materials are disposed off in such a manner that there is no likelihood of its getting mixed with the materials proposed to be used for embankment construction.
- 6.2.5 **COMPACTING ORIGINAL GROUND:** In all cases where condition permit, the original ground shall be consolidated as much as reasonably possible or as directed by the Engineer-in-Charge by rolling or other means. Any empty pockets or depressions left in the soil as a result of clearing grubbing operations shall be filled & compacted. Nothing extra shall be paid for these operations.
- 6.2.6 Where so directed by Engineer-in-Charge any unsuitable materials occurring in the embankment foundation shall be removed & replaced by approved materials.
- 6.2.7 Where the embankment is to be placed on steep sloping ground the surface of the ground shall be benched in step or trenched or broken up in such manner that the new materials will have bond with existing surface & the cost thereof shall be included in the tendered rate.
- 6.2.8 Where the embankment is to be placed over an existing road surface, the surface shall be scarified, so as to provide sample bond between old & new materials.

6.2.9 Embankment work shall not proceed until the foundation have been inspected by the Engineer-in-Charge for satisfactory & approved.

### **6.3 CONSTRUCTION PLACING OF EMBANKMENT MATERIALS:**

6.3.1 Only materials as approved by the Engineer-in-Charge shall be utilized in the embankment. The work shall be so planned & executed that the best available materials are saved for the top portion of the embankment & sub-grades. Approved materials shall be obtained from approved area.

6.3.2 **EMBANKMENT SLOPES:** The embankment shall be built to have side slopes as shown in the drawings or as directed by the Engineer-in-Charge of the work.

6.3.3 **PLACING SOIL IN LAYERS:** To obtain adequate compaction, the embankment shall not be placed until the layer under construction has been thoroughly compacted to satisfy the requirements laid down here after.

To ensure correctness, the execution of the toe-lines on the embankment shall be marked carefully with pages at close interval. The profile with due allowance for settlement shall be set up with the help of bamboos & string. The earth work of the embankment will be carried on uniformly in layer according to these profiles. Due care shall be exercised to ensure the loose thickness of each layer does not exceed the specified limit.

6.3.4 Layers exceeding 9" in loose depth shall be permitted only when the Engineer-in-Charge is satisfied that the compaction plant proposed to be used will achieve the specified compaction throughout the whole depth of the layer. Provided further that when a VRR is used the thickness of the loose layer shall not exceed the length of the tamping feet by more than 2". The embankment materials shall be deposited in layer not more than 9" loose thickness unless otherwise specified & compacted to 100% proctor density at O.M.C with P.R.R.

6.3.5 Unless otherwise directed, the soil shall be spread uniformly over the entire width of the embankment.

6.3.6 If the soil shall less than the desired moisture content water shall be added to it either in the borrow pits before excavation is made, or after the soil is spread loosely on embankment without any extra charge. Addition of water may be made in the former case through flooding or irrigating the borrow area & in the latter case through sprinkling the water either directly from a hose line or from a truck mounted water tank.

6.3.7 If the soil as delivered to the road formation is too wet, it shall be dried, by aeration & exposure to Sun, till the moisture content is acceptable for compaction.

Should circumstances arise where owing to wet weather the moisture content of certain soil can not be reduced to the appropriate amount by aeration, the compaction of these soils shall be suspended.

6.3.8 After adjusting the moisture content the soil shall be processed by the means of graders, borrows rotary mixers or other suitable equipment, until the layers are uniformly wet without any cost of Govt.

Clods or hard lumps of earth shall be broken down to size preferably of the order of 5 cm. (2") but under no circumstances shall be maximum size of such clods exceed 15cm. (5") when being placed in the body of the embankment & the maximum size shall not exceed 6 cm. (2.5") when being placed on the top to a depth of 50 cm. (18") of the embankment.

#### 6.3.9 MOISTURE CONTENT & DENSITY:

The moisture content of each layer of soil at the time of compaction should be as directed by the Engineer-in-Charge. The M.C. of each layer of soil at the time of compaction should be at O.M.C . However, the tolerance limits for this MC of the soil with respect of OMC are between 1% above the optimum & 2% below the optimum value. The soil spread in layers shall be thoroughly compacted to the required densities & stipulated by IRC in their code 31.32 para 15.3, 15.4, 15.5 & 16. Each layer will be tested in field, for density & pronounced accepted by the Engineer-in-Charge before the next layer is laid.

6.3.10 The surface of the embankment shall at all times during construction be maintained as such a cross fall as will shed water & prevent pounding.

#### 6.4 EMBANKMENT AROUND STRUCTURES

6.4.1 The filling around & over culverts & other structures in the embankment area shall be carried out independently of the work on the main embankment. The embankment shall be brought up simultaneously in equal layer on each side of the structure to avoid displacement & unequal pressure.

6.4.2 The soil in such cases shall be deposited in layers not exceeding 6" loose thickness & shall be compacted thoroughly & to the satisfaction of the Engineer-in-Charge. Where it may be impracticable to use power rollers or other heavy equipment, the compaction shall be carried out by mechanical tampers or other approved methods.

#### 6.5 COMPACTION CONTROL :

6.5.1 PRELIMINARY INVESTIGATION: Preliminary investigations shall be made by the contractor at his own cost as per direction given by the Engineer-in-Charge to determine the most economical procedure to be adopted to obtain the specified degree of compaction & the necessary field control (as a result of the suggested investigations it is generally found that it is sufficient to ensure that the soil laid in layers of the specified thickness, with the specified moisture, & is rolled with the number of passes of the compaction equipment which are found to produce the specified degree of compaction).

6.5.2 The compaction control on the work in the field will be exercised by the deptt through frequent moisture content & density determination. The following control test shall be made on the borrow materials.

Sl. No.	Test	Test Method	Min. desirable frequency
1	Gradation	I.S. 2720 Pt. IV	1-2 tests per 300 cum of soil
2	P.I	I.S. 2720 Pt. V	1 Test for 25 M <sup>3</sup>
3	Standard Proctor test	I.S. 2720 Pt. VII	-do-
4	Deleterious constituents	I.S. 2720 Pt. XXVII	As required
5	Natural M.C	I.S. 2720 Pt. II	One test for 250 M <sup>2</sup> of soil
6	Dry density	I.S. 2720 Pt. XXVII	Generally at least one test per 100 M <sup>2</sup> of compacted area for the body of embankment to be increased to one test 500-1000 cum of compacted area for the top sub grade layers of 50cm or 1-2 tests for 3000 cum of soil.

## 6.6 ANALYSIS & ACCEPTANCE OF DENSITY RESULTS

- 6.6.1 Except otherwise directed, at least one measurement of density shall be made for each 1000 m<sup>2</sup> (10000 sqft.) compacted area. Test locations shall be chosen only through predetermined random sampling techniques. Control shall not be based on the result of any one test but on the mean value of 5-10 density determination. The number of tests in one set of measurements shall be 5 as long as it was felt that sufficient control over borrow materials & the method of compaction was being exercised, but if there was any doubt about this control, or considerable variations were observed between individual density result the minimum number of tests in one set of measurement shall forthwith be increased to 10. The acceptance of results shall be subject to condition that the mean dry density equals or exceeds the specified density & the standard deviation for any set of result in below 0.88 gm. Per cc (5 lb per cu. Ft.)
- 6.6.2 In general, the control at top sub-grade layers of the formation shall be more strict, with density measurements being done as stated above, at the rate of test per 500-1000 sq.ft. (50-100) sqm. Of compacted area. Further for the determination of mean density & standard deviation, the number of tests in one set of measurements shall not be less than 10. In other respects, the control will be similar to as spelt out in the previous para.
- 6.6.3 If for any reason it has not been found possible to conduct the minimum number of test mentioned above, the test value obtained from fewer tests shall be used only as an aid to judgment & as a proof of the quality of the work.
- 6.6.4 The value of the "Standard deviation" shall be calculated from the formula:

$$Q = \frac{1}{n} \sqrt{nEx^2 (Ex)^2}$$

Q = standard deviation in gm/cc/ (lb/cu. Ft.)

n = total number of density measurement, &

x = value of dry density in gm per cc (lb/cu ft.)

CONTRACTOR

## 6.7 REMOVAL OF SOFT AREAS:

When density measurements reveal any soft areas in the embankment, the Engineer-in-Charge shall direct that these areas should be compacted further & nothing extra shall be paid. In spite of that, if the specified compaction is not achieved, the materials in the soft areas shall be directed to be removed & replaced by approved materials, compacted to the satisfaction of the Engineer-in-Charge.

## 6.8 COMPACTION IN ORDINARY WAY

The Engineer-in-Charge shall indicate the portion of the earthwork which are not required to be compacted to a specified degree of density & moisture content. The embankment in such portion shall be carried out as specified above, each layer being consolidated as far possible with the help of iron rammers, ordinary light rollers or sheep foot roller, if available. The layers shall be laid concave slopping from the edges toward the centre. The earth shall be laid from the sides to the centre & not vice versa. If the earthwork remains suspended for some time & the surface becomes hard, the latter shall be roughened & slightly moistened before resumption of work without any extra charge to Govt.

## 6.9 FINISHING OPERATIONS:

- 6.9.1 After the earthwork is completed & consolidated, sectioning shall be done to bring it to its true final shape. The embankment shall be finished in conformity with the alignment levels, cross sections & dimensions shown on the plans. Where the alignment of the road is in a curve, the tops of the embankment shall be formed with the supervision & the increased widths shown on the drawing or as the Engineer-in-Charge may direct without any extra cost to Govt.
- 6.9.2 Finishing operation shall include the work of shaping & dressing the shoulders road bed & the side slopes to conform to the typical cross section shown on the plan & shall be paid extra. Both the upper and lower ends of the side slopes shall be rounded off to improve appearance & to merge the embankment with an adjacent terrain.
- 6.9.3 When the earth work operations have been substantially complete the road way area shall be cleaned of all the debris & ugly scars existing near the coming areas etc. Every reasonable effort shall be made to avert objectionable appearance without any extra payment.

## 6.10 SPECIFICATION FOR MOORUM SUB-BASE:

- 6.10.1 **MATERIALS:** Moorum shall be composed of large, coarse grains, sharp & gritty. Moorum should not contain lumps of soil, foreign matters, it should not contain stones greater than  $\frac{3}{4}$ " in gauge. It should show a uniform C.B.R value which should not be less than 20 for sub-base. The P.I. should not be more than 9.

## 6.11 PROCESSING & CONSTRUCTION

- 6.11.1 The sub-grade shall be checked for line grade & cross section as shown in the drawing or as directed by the Engineer-in-Charge. Soft & yielding places & ruts shall be corrected & rolled uniform. It shall be laid in layers from 6" to 9" thickness. It shall be well watered & compacted with PRR or other suitable machinery as directed by the Engineer-in-Charge to obtain the desired compaction form.

- 6.11.2 Rolling shall commence at the edges, progressing gradually towards the centre, parallel to the centre line of the road except at super elevated portions where it shall proceed from the inner edge to the outer.
- 6.11.3 The finished surface shall be checked for line, level & irregularity as directed by the Engineer-in-Charge.
- 6.11.4 Irregularities present in the finished surface beyond the tolerance of 20mm. shall be rectified as mentioned in 10.12.5 below.
- 6.11.5 Where the finished surface of the sub grade is too high it shall be trimmed & suitably compacted & where the same is too low, the deficiency shall be corrected by adding fresh materials. The degree of compaction & the type of materials to be used shall conform to the specification & requirement.

**6.11.6 Control tests & their frequencies:**

Quality control tests on the materials & work be as indicated below:

Sl. No.	Type of Construction	Test	Frequently
1	Water bound macadam	(i) Aggregate impact value loss Angles test abrasion value	One test per 200 cum
		(ii) Grading	One test per 100 M <sup>2</sup>
		(iii) Flakiness index	One test per 200 cum
		(iv) Non-Plastic binding materials	One test per 25 cum
		(v) Proctor test	One test per 200 cum
		(vi) Deleterious constituents	As required
		(vii) M.C	One test per 250 sqm
		(viii) D.D of compacted layer	One test per 1000 sqm
		(ix) C.B.R test	One test per 1000 sqm
2	Bituminous construction	(i) Aggregating impact value/ Los angle	One test per 50 cum of aggregate
		(ii) Flakiness Index	-do-
		(iii) Grading of aggregate	One test per 25 cum
		(iv) Temperature of binder application	At regular close intervals
		(v) Rate of spread of mixed materials	Regular control through checks on materials & layer thickness.

## 7. SPECIFICATION FOR TURFING

7.1 DESCRIPTION: This work shall consist of supplying & laying live sods on the slopes & other locations as required by the Engineer-in-Charge, in accordance with the following specifications.

7.2 MATERIALS: The sods shall consist of dense well rooted growth of permanent & desirable grasses, indigenous to the general locality where it is to be used, & shall be practically free from weeds or undesirable grasses. At the time the sod is out, the grass on sod shall have a length of approximately 2 inches; if longer, the grass shall be cut to approximately this length & the sod shall have been raked from debris.

The sod shall be cut in uniform strips not larger than it is convenient for handling & transport. The thickness of the sod shall be as uniform as possible approximately  $\frac{3}{4}$  inches or more, depending on the nature, of the sod, so that practically all the dense root system of the grasses will be retained but exposed in the sod strip & so that the sod can be handled without undue tearing breaking.

In the event the sod which is to be cut is in dry condition, so as to cause crumbling or breaking during cutting operations, the contractor, at his own expense, shall at least 12 hours before cutting the sod, apply water to the same in sufficient quantities to provide a well moistened condition of the sod to the depth to which it is to be cut.

Top soil of the area to be turned shall consist of soils adopted to the sustenance of plant life.

### 7.3 CONSTRUCTION METHOD

7.3.1 PREPARATION OF THE EARTH BED: All areas desired to be covered with sod shall be fine dressed to required contour, to an extent such that the finished work after laying sod with necessary soil incorporated in the bed will be in accordance with required lines grades, slopes & cross section.

The area to be sodden shall be free from stones, roots or other undesirable foreign materials.

The soil of the area to be sodden shall be loosened to a depth of approximately not less than one inch, by means of rakes adopted to the purpose & top soil shall be spread evenly over the prepared bed to a depth of 2 inches & the clods lumps shall be broken down to provide a uniform texture to the sod.

7.3.2 PLACING THE SOD: The earth bed upon which the sod is to be place shall be moistened to the depth, manipulated, if naturally not sufficiently moist, & the sod shall be place thereon within approximately 24 hours after the same has been cut & shall be properly protected & sprinkled with water until firmly rooted.

Unless otherwise required the sod on slopes shall be laid in horizontal, strips beginning the bottom of the slopes & working upwards. When placing sods the length of strips shall be laid at right angles to the direction of flow of water. Sods shall be laid so that the joints caused by abutting ends of sod strips & not continuous. Each sod strips shall be so laid as to abut against the strip previously laid.

7.3.3 As the sod is being laid to shall be firmly & lightly tamped with suitable wooden or metal tampers to press the sod into the under laying soil. After tamping, the sod shall present a smooth even surface free from bumps or depressions. At such points, where water will start flowing over a sodden area, the upper edge of the sod strip shall be turned into the soil & layer of earth placed over this, which earth shall be thoroughly compacted to conduct the surface water over the upper edge of the sod. No sods shall be laid normally during the dry months of March to June.

7.3.4 WATERING: The sod shall be thoroughly watered immediately after placing & shall be kept thoroughly wet for a period of at least seven days after laying & shall be maintained in satisfactory condition.

7.3.5 **METHODS OF MEASUREMENT & PAYMENT:** Sod shall be measured by units of 100 sqm. & will be paid for at the contract unit price of 100 sqm. of sod in place which price shall be full compensation for preparing the earth bed, for furnishing, placing, top dressing & watering the sod & for all labour, equipment tools & incidentals necessary to complete the work in accordance with contract.

Collection of top soil for the area to be turned will be paid for as earthwork in excavation.

No separate payment will be allowed for spreading & incorporating the top soil in the bed.

**8 STANDARD SPECIFICATION & CODE OF PRACTICE FOR WATER BOUND MACADAM**

**INTRODUCTION:** The standard is a code of practice intended to indicate what is considered to be a good practice for the construction of water bound macadam & surface treated water bound macadam.

**8.1 DESCRIPTION**

Water bound macadam shall consist of clean crushed coarse aggregate mechanically interlocked by rolling & voids thereof filled with screenings & binding material with the assistance of water laid on a prepared sub-base, base or existing payment as the case may be water bound macadam may be used as sub-base, base coarse or surfacing course. In each case, it shall be constructed in accordance with the specification given & below in conformity with the lines, grades & cross sections shown on the drawing or as otherwise directed.

**MATERIALS**

8.1.1 Coarse aggregate General Requirements.

8.1.2 Coarse aggregate shall be either crushed or broken stone, crushed slag, over burnt metal or naturally occurring aggregate such a kankar or literate or requisite quality as stated here in after. The aggregate shall conform to the physical requirements set forth in Table-1.

8.1.3 Crushed or broken stone.

Crushed or broken stone shall be hard, durable & generally free from flat, elongated soft & disintegrated particles. It shall also not have excess or dirt or other objectionable matter.

8.1.4 Table – 1: Physical requirements or coarse aggregate for water bound macadam.

( I.R.C 19. 1972)

Sl.No.	Type of construction	Test	Test Method	Requirement
1	Sub-base	Los Angles Abrasion value * or Aggregate Impact Value*	IS: 2386 (part-IV) Or IS: 5640	Max. 50%  Max. 40%
2	Base course with bituminous surfacing	(a) Los Angles Abrasion value* or Aggregate Impact value* (b) Flakness Index*	IS: 2386 (part-IV)  IS: 2386 (part-IV)  IS: 5640 IS:2386 (part-I)	Max. 50%  Max. 40%
3	Surfacing course	(a) Los Angles Abrasion value* or Aggregate Impact value* (b) Flakness Index*	IS:2386 (part-IV)  IS: 5640 (part-IV)  IS:5640 IS:2386 (part-IV)	Max. 40%  Max. 40%  Max. 15%

NOTE:- \* Aggregate may satisfy the requirements of either the loss angles test or aggregate impact value test.

\*\* Aggregate like brick, metal, kankar & laterite which get softened in presence of water, should invariably be tested for impact value in wet condition accordance with IS:5640.

\*\*\* The requirement of frankness index shall be enforced only in the case of crushed stone & crushed slag.

Samples for tests shall be representative of the materials to be used collected in accordance with the procedure set forth in IS:2430.

8.1.5 **CRUSHED SLAG** : Crushed slag shall be manufactured from air-cooled blast furnaces slag. It shall be angular shape, reasonably uniform in quality & density, & generally free from any thin, elongated & soft pieces, dirt or other objectionable matter. Crushed slag shall not weigh less than 1120 kg. ccm & the percentage of glossy materials in it shall not be in excess of 20%. Water absorption (IS:2386 part-III) of slag shall not exceed 10%.

8.1.6 **OVER BURNT BRICK METAL**: Brick metal shall be made out of over burnt bricks of bats & be free dust & other foreign matter.

8.1.7 **KANKAR** : Kankar shall be tough, having a blue almost opalescent fracture. It shall not contain any clay cavities between nodules.

8.1.8 **LATERITE** : Laterite shall be hard, compact, heavy & of dark colour. Light coloured sandy laterites as also those containing a good bit on clay shall not be utilized.

**8.1.9 COURSE AGGREGATE: SIZE & GRADING REQUIREMENTS**

8.1.10 As far as possible coarse aggregates shall conform to one of the grading given in Table-2. Grading 1 is more suitable for sub-base course, but it is not tenable for a compacted layer thickness or less than 90mm.

8.1.11 The size of aggregate to be used in a given case would depend on the type of aggregate available & compacted thickness of the layer. The use of grading-1 shall how ever, be restricted to sub-base courses only.

8.1.12 For crushable type aggregate like brick metal, kankar & laterite, the grading given in Table-2 are not so relevant & need not be strictly enforced but the material should generally be within the size range indicated.

8.1.13 Table-2: SIZE & GRADING REQUIREMENT OF COURSE AGGREGATE FOR W.B.M.

Grading No.	Size of screenings	Sieve Designation (IS:460)	Percent by weight Passing the Service
1	90mm. to 45mm.	125 mm.	100
		90 mm.	90 – 100
		63 mm.	25 – 60
		45 mm.	0 – 15
		22.4 mm.	0 – 5
2	63mm. to 45mm.	90 mm.	100
		63 mm.	90 – 100
		53 mm.	25 – 75
		45 mm.	0 – 15
		22.4 mm.	0 – 5
3	53mm. to 22.4m.	63 mm.	100
		53 mm.	95 – 100
		45 mm.	65 – 90
		22.4 mm.	0 – 10
		11.2 mm.	0 – 5

**SCREENINGS :**

- 8.1.14 Screening to fill voids in the coarse aggregate shall generally be of the same materials as the coarse aggregates. However, from economic considerations, predominantly non-plastic material such as kankar nodules, moorum or gravel (other than river borne rounded aggregate) may also be utilized for this purpose provided that the liquid limit & plasticity index of such material is below 20 & 6 respectively & the fraction passing 57 micron sieve does not exceed 10%
- 8.1.15 As far as possible, screenings shall conform to the grading shown in Table-3. Screenings of type A in Table 3 shall be used in conjunction with coarse aggregate of grading-II. With coarse aggregate of grading-2 either type A or type B screenings may be used. For screenings like moorum & gravel the grading given in Table-3 shall not be regarded as binding. Type B screenings shall be used with coarse aggregate.
- 8.1.16 The use of screenings may be dispensed with in the case of crushable type coarse aggregate such as brick metal, kankar & laterite.
- 8.1.17 TABLE -3 : GRADING REQUIREMENTS OF SCREENINGS FOR W.B.M.

Grading Classification	Size of screenings	Sieve Designation (IS :460)	Percent by weight Passing the Service
A	13.2 mm.	13.2 mm.	100
		11.2 mm.	95 - 100
		5.6 mm.	15 - 35
		180 micron	0 - 10
B	11.2 mm.	11.2 mm.	100
		5.6 mm.	10 - 100
		180 micron	15 - 35

- 8.1.18 BINDING MATERIALS: Binding materials to prevent reveling of water bound macadam shall consist of the fine grained materials possessing P.I. value of 49 when the WBM is to be used as a surfacing course & upto 6 when the WBM is being adopted as a sub-base/ base course with bituminous surfacing. If lime stone formations are available nearby lime stone dust or kankar nodules may be usefully employed for this purpose.
- 8.1.19 Application of binding material may not be necessary where the screening consist of crushable type material like moorum or gravel. However, for WBM used as a surfacing course, where the P.I of crushable type screening is less than 4, application of a small amount of binding material having P.I. of 4 to 9 would be required at the top. The quantity of screening could be reduced slightly on this account.
- 8.1.20 QUANTITIES OF MATERIAL : Approximate quantities, of coarse aggregate & screening required for 100 mm. compacted thickness of WBM. Sub-base course are shown in Table-4, likewise rough quantities of materials for WBM base of surfacing course for a compacted thickness 75 mm. are given in Table-5.

8.1.21 The quantity of binding material where it is to be used (see para 12.3.5) will depend on the type of screenings & function of WBM. Generally, the quantity required for 75 impacted thickness will be 0.06 to 0.09 ccm per 10 mm. in the case of WBM sub-base.

TABLE-4 APPROXIMATE QUANTITIES OF COURSE AGGREGATES & SCREENINGS REQUIRED FOR 100 MM. COMPACTED THICKNESS OF W.B.M. SUB-BASE COARSE FOR 10 MM.

Coarse Aggregates			Screenings			
Classification	Size range	Loose quantity	Stone screenings		Crushable type such as moorum or gravel	
			Grading/ Classification & Size	Loose Qnty.	Grading/ Classification & Size	Loose Qnty.
1	2	3	4	5	6	7
Grading	90 to 45 mm.	1.21 to 1.49 ccm	Type A 13.2 mm.	0.27 to 0.30 ccm	Not uniform	0.30 to 0.32 ccm

TABLE-5 APPROXIMATE QUANTITIES OF COURSE AGGREGATES & SCREENINGS REQUIRED FOR 75 MM. COMPACTED THICKNESS OF W.B.M. SUB-BASE COARSE/ SURFACING COURSE FOR 10 MM.

Coarse Aggregates			Screenings				
Classification	Size range	Loose quantity	Stone screenings		Crushable type such as moorum or gravel**		
			Grading/ classification & size	For WBM sub-base / base course	For WBM surfacing course *	Grading/ classification & size	All cases
1	2	3	4	5	6	7	8
Grading-2	63 to 45 mm.	0.92 to 1.07 ccm	Type A 13.2 mm.	2.12 to 0.15 ccm	0.11 to 0.17 ccm	Not uniform	0.22 to 0.24 ccm
-do-	-do-	-do-	Type B 11.2 mm.	0.20 to 0.22 ccm	0.24 to 0.26 ccm	-do-	-do-
Grading-3	53 to 22.4 mm.	-do-	-do-	0.18 to 0.21 ccm	0.22 to 0.24 ccm	-do-	-do-

\* Quantities in col. 6 are 80% of those in col 5 as larger quantity of binding material will need to be used when the WBM is to act as a surfacing course.

\*\* Base course & 0.10 to 0.15 ccm/ 10 ccm when the WBM is to function as a surfacing course. For 100 mm. thickness the quantity needed respectively will be 0.08 to 0.10 ccm/ 10 ccm. & 0.12 to 0.16 ccm/ 10 mm.

The above mentioned quantities should be taken as guide only for estimation of quantities for construction etc. & not for the purpose of payment which should be made as per actual.

## 8.2 CONSTRUCTION PROCEDURE

8.2.1 **PREPARATION OF FOUNDATION OF RECEIVING THE WBM COURSE:** The sub-grade, sub-base to receive the water bound macadam course shall be prepared to the required grade & camber & cleaned all dust, dirt & other extraneous matter. Any rust or soft yielding places that have appeared due to improper drainage service or under traffic or other reasons shall be corrected & rolled until firm.

- 8.2.2 Where the water bound macadam is to be laid on existing un-surfaced road, the surface shall be scarified & re-shaped to the required grade & camber as necessary. Weak place shall be strengthened corrugations removed & depressions & pot holes made good with suitable material before spreading the coarse aggregate for WBM.
- 8.2.3 Where existing road surface is black topped, 50 mm. x 50 mm. furrows shall be cut in the existing surface at 1 mtr. Intervals at 45 degree to centre line of the carriage way before proceeding with the laying of coarse aggregates.
- 8.2.4 In all cases the foundation shall be kept well drained during the construction operations.
- 8.2.5 **PROVISION OF LATERAL CONFINEMENT OF AGGREGATE:** Before starting with WBM construction, necessary arrangements shall be made for the lateral confinement of aggregates. One method is to construct side shoulder in advance to a thickness corresponding to the compacted layer of the WBM coarse. After shoulders are ready, their inside edge may be trimmed vertical & the included area cleaned of all spoiled material there by setting the stage for spread of coarse aggregates. The practice of construction WBM in a trench section, excavated in the finished formation must be completely avoided.
- 8.2.6 **SPREADING COARSE AGGREGATE:** The coarse aggregates shall be spread uniformly & evenly upon the prepared base in required quantities from premature stack piles along the side of the road or directly from vehicles. In no case shall these be dumped in heaps directly on the area where are to be laid nor shall their hauling over a partly completed base be permitted. The aggregates shall be spread to proper profile by using templates placed across the road about 6 mtr. apart. Where possible approved mechanical device shall be used to spread the aggregates uniformly so as to minimize the need for manipulation by hand.
- 8.2.7 The WBM course shall normally be constructed in layers of not more than 75 mm. compacted thickness. However for aggregates of grading table-2, the compacted thickness of layer may go up to 100 mm. Each layer shall be tested by depth blocks. No segregations of large & fine practices shall be allowed in the coarse aggregates as spreading shall be of uniform gradation with no pockets of fine materials.
- 8.2.8 The coarse aggregate shall not normally be spread in length exceeding three days average work ahead of rolling & binding the proceeding section.

### 8.3 ROLLING

- 8.3.1 After the laying of coarse aggregate, there shall be compacted to full width by rolling with either three wheel power roller of 6 to 10 tones capacity or an equivalent vibratory roller. The weight of the roller shall depend on the type of the aggregates.
- 8.3.2 The rolling shall begin from edges with roller running forward & backward until the edges have been compacted. The roller shall then progress gradually from the edges towards the centre parallel to the centre line of the road, uniformly lapping preceding rear wheel track by one half width. Rolling shall be discontinued when the aggregates are partially compacted with sufficient voids space in time to permit application of screenings. However where screenings are not to be applied, as in the case of crushable aggregates like brick metal, laterite & kankar, compaction shall be continued until the aggregates are thoroughly keyed or interlocked with no creeping of stones ahead of the roller. Slight sprinkling of water may be done during rolling if necessary.

- 8.3.3 On super elevated portion of the road, rolling shall commence from the lower edge & progress gradually towards the upper edge of the pavement.
- 8.3.4 Rolling shall not be done when the sub-grade is soft or yielding nor when it causes a wave like motion in the base course/sub-grade. If irregularities develop during rolling which exceeds 10 mm. when tested with a 3 mtr. straight edge the surface shall be loosened & aggregates added or removed as required before rolling again so as to achieve uniform surface conforming to the desired cross section & grade. The surface shall also be checked transversely the template for camber & any irregularities corrected in the manner described above. In no case shall the used of screenings to make up depressions be permitted.

#### **8.4 APPLICATION OF SCREENINGS**

- 8.4.1 After coarse aggregates have been rolled as para 12.5 screenings to fill the interstices shall be applied gradually over the surface. Dry rolling shall be done when the screening are being spread so that the jarring effect or roller causes them to settle into the voids of the coarse aggregates. The screenings shall not be dumped in piles but applied uniformly in successive thin layers either by the spreading motion on hand shovels, mechanical spreaders or directly from the trucks playing over the base course to spread screenings that shall be equipped with pneumatic tires & so operated as not to disturb the coarse aggregates.
- 8.4.2 The screenings shall be applied at a slow rate in three or more applications as necessary. This shall be accompanied by rolling an brooming either by mechanical brooms/ hand brooms or both than may be used. In no case shall the screening be applied so fast & thick as to form cakes or ridges on the surface making the filling of voids difficult or preventing the direct bearing of roller on the coarse aggregates. The spreading rolling & brooming of screening shall be taken up on sections which can be completed within one day's operation. Damp & wet screenings shall not be used in any circumstances.

#### **8.5 SPRINKLING & GROUTING**

- 8.5.1 After application of screenings the surface shall be copiously sprinkled with water swept & rolled. Hand brooms shall be used to sweep the screening into the voids & distribute them evenly. The sprinkling, sweeping the rolling operations shall be continued & additional screenings applied where necessary until the coarse aggregate are well bound & firmly set & a grout has been formed of screenings. Care shall be taken that the base or sub-grade does not get damage due to addition of excessive quantities of water during the construction.

#### **8.6 APPLICATION OF BINDING MATERIAL**

- 8.6.1 After the application of screenings as per paras 12.6 & 12.7 binding materials where it is required to be used (see para above) shall be applied at the uniform & slow rate in two or more successive thin layer. After each application of binding material, the surface shall be copiously sprinkled with water & resulting slurry swept in with hand brooms, mechanical brooms or both so as to fill the voids properly. This shall be followed by rolling with a 6 to 10 ton roller during which water shall be applied to the wheels to wash down the binding material, that may get stuck to them. The spreading of binding material, sprinkling of water sweeping with brooms & rolling shall continue until the slurry of binding material an water forms and wave ahead of the wheels of moving roller.

## 8.7 SETTING & DRYING

8.7.1 After final compaction of the course, the road shall be allowed to cure overnight next morning the hungry spots shall be filled with screening or binding materials lightly sprinkled with water if necessary & rolled. No traffic shall be allowed till the macadam sets.

8.7.2 In case of water bound macadam base course to be provided with bituminous surfacing, the latter shall be laid only after the WBM course it completely dry & before allowing any traffic on it.

## 8.8 PLAYING OF CONSTRUCTION TRAFFIC

8.8.1 In general construction traffic may ply over compacted portion of the WBM course provided move over its full width avoiding any rutting or uneven compaction. However, Engineer-in-Charge shall have full authority to stop the passage of construction traffic when in his opinion this is leading to excessive damage.

## 9 SURFACE EVENNESS OF WBM COURSE COMPLETED

9.1 The surface evenness of complete WBM course in longitudinal & transverse directions shall be within the tolerances indicated in Table-6

TABLE – 6 PERMITTED TOLERANCES OF SURFACES EVENNESS FOR WBM COURSE

Sl.No.	Size range of coarse aggregates	Longitudinal profile (Maximum permissible undulation when measured with a 3 mtr. straight edge)	Cross profile (Maximum permissible variation from specific profile when measured with a camber template)
1	40 to 90 mm.	15 mm.	10 mm.
2	25 to 50 mm. or 40 to 63 mm.	12mm.  12mm.	8 mm.  8 mm.

9.2 The longitudinal profile shall be checked with 3 mtr. long straight edge at the middle of each traffic lane along a line parallel to the centre line of the road. The transverse profile shall be checked with a series of three camber boards at intervals of 10 mtr.

## 10 RECTIFICATION OF DEFECTIVE CONSTRUCTION

10.1 Where the surface irregularity of the WBM course exceeds the tolerance given in Table-6, where the course is otherwise defective due to sub-grade soil mixing with the aggregates, the layer to its full thickness shall be scarified over the affected area, reshaped with added material or removed the replaced with freshed materials as applicable & recomputed in accordance with para 12.5. The depressions be filled up with screenings or binding materials

## 11 CONSTRUCTION OF WBM NARROW WIDTHS

11.1 Where the WBM course is to be constructed in narrow widths for widening an existing pavement, the following sequences of operations should be adopted.

(i) The existing shoulder should be excavated to their full depth & width upto the sub-grade soil except where the widening the widening specification envisages laying of stabilized soil sub-base using in situ operations in which case same should be removed only upto the sub-base level.

(ii) Before proceeding with laying of WBM course, shoulders be rebuilt in layer in reduced width depending on the extent of widening. The compacted thickness of each layer should correspond to the compacted layer of WBM course to be laid adjacent to it. After compaction the inside edges of shoulder should be trimmed vertical & the included area cleared of all spilled materials and

(iii) The construction of WBM layer should then follow the usual manner.

## **12 MAINTENANCE OF WBM WEARING COURSE.**

12.1 The successful performance of WBM as a surfacing course depends to a large extent on wearing maintenance. Maintenance measures for this can be considered under three heads, periodic patching of pot holes along with removal of ruts & depression, blinding of the surface the surface renewal.

12.2 **PATCHING POT-HOLES & RUTS:-** Pot holes, ruts & other depression should be drained of water & cut to regular shape with vertical sides. All the loose & disintegrated materials shall be removed & the exposed surface swept clean. The holes, depression shall then be filled with salvaged coarse aggregates mixed with sufficient quantity of fresh aggregates & re-compacted as normal. W.B.M. Operations described in para 12.5 so that the patched area merge with the adjoining surface. Where the area so treated is small, hand rammers may be used for compaction instead of rollers.

12.3 **BLINDING OF SURFACE:-** Blinding of the surface shall be resorted to periodically as soon as the blinding material applied has been eroded away due to traffic or weather action & the surface has started showing signs of disintegration. Blinding operations shall consist of application of blinding material in this layers & grouting in accordance with the procedure given in previous para.

## **12.4 SURFACE REVEWAL**

12.4.1 WBM wearing course shall be renewal when the surface is worn out, corrugated & badly damaged or has profusions of pot-holes & depression which can not be treated economically with patching or blinding operation.

12.4.2 For renewal, the existing surface shall be scarified to a depth of 75 mm. & the resulting materials removed to beams for screening to salvage the useable coarse aggregates. The exposed pavement shall be scarified against at high spots so as to ensure proper grade & camber. The salvaged coarse aggregates are mixed with sufficient quantity of fresh aggregates. Usually between one half to one third of the quantity of salvaged aggregates shall be used for construction of new WBM course in accordance with para 16.2.

## **13 RECONSTRUCTION DAMAGED MACADAM**

If any time sub-grade material should get mixed with the base course materials, the mixture shall be removed an the sub-grade shaped & compacted. The materials removed shall then be placed with clean aggregate, which shall be rolled until satisfactory compaction is achieved. If any irregularities develop in the sub-grade

during or after rolling of the sub-course, they shall be corrected by lessening the surface & removing or adding coarse aggregates as may be require, after which the entire area shall be rolled, screenings & water applied & rolling continued until the repaired based in compacted to uniform surface. The finished surface shall have no variation greater than 12 mm. (1/2 in) from 3 mtr. (10 ft.) long straight edge laid parallel to the centre line of the road & be true to the typical cross section.

#### **14 MULTIPLE LAYERED COURSE**

When it is necessary to construct to course in more than one layer to conform to the lines, grades & cross sections indicated on the plans, or as directed by the Engineer-in-Charge, each layer shall be constructed as described above. The same degree of requirement shall be made in forming the surface of all component layers & the smoothness & uniformity of the surface of each layer shall conform closely to the requirements for surface to the final layer.

#### **15 PROTECTION**

In general, hauling equipment may be routed over completed portion of the WBM course, provided such equipment is routed over the full width of the course avoiding rutting or uneven compaction. However, Engineer-in-Charge have full & specific authority to stop all hauling over completed or partially completed course when, in his opinion such hauling is causing excessive damage.

During the placing, spreading & compacting of coarse aggregate & screenings, care shall be exercised to prevent the incorporation of sub-grade, sub-base or shoulder material into these macadam materials.

N.B: \* Plasticity index not more than 9 in base of WBM & 6 in case of surface treated WBM.

#### **16 PROFILE MARKING**

16.1.1 **Marking of alignment:-** Centre line of the alignment should be laid out according to the sanctioned plan with the help of ranging rods, flags or theodolite. Permanent brick pillars 10" x 10" should be fixed 660 ft. apart on one side of the alignment at a constant distance of about 50 to 75 ft. away from the centre line depending upon the land width. These pillars would then form a line parallel to the centre line of the alignment but side shifted by about 50 to 75 ft. These pillars shall show the formation level of the earth work bank & the chainage of the alignment as per sanctioned plan & longitudinal sections. These shall be legibly marked.

16.1.2 **Marking the profile:** The profile should be marked at intervals not exceeding 200 or so except at curves where closer profile shall be necessary. The toe line of the embankment should be fixed first. These can be calculated on the basis of the slope (1:2 or 1:3) & the height of the embankment as per sanctioned plan at the particular section. Two sal bullahs or bamboo piles well embedded in the ground should be fixed at the toe lines & top of the poles should be kept in one level with the help of leveling instruments. These poles should have alternate 6" thickness printed black & white to show the layer or consolidated earth to be done. Such sets of poles should be fixed at distances not exceeding 20 ft. along the alignment.

16.1.3 **SEQUENCE OF OPERATION FOR EARTH WORK & FIXING PROFILES AT VARIOUS LAYERS:** The various sequence of operation for making profiles & various layers are shown in diagrammatic sketches in Fig-2 to 2(c) (enclosed) The figures shown are 1:2 side slope but similarly distance can be worked out for other slopes.

16.1.4 **FIRST LAYER:**

Horizontal string S1-S2 should be tied at height of 9" (i.e. after one & half mark on the pole) joining poles A&B. Two small pegs (about 18" long) should be fixed in ground (capable of being taken out fairly easily) (K1, K2 at distance of 18" for 1:2 slope) from poles A&B respectively & sloping string S4 (meeting point of pages K1 & K2 with horizontal string S1-S2 & S5 (to line) should be tied. These string profiles S5-S4, S4-S5 marked over 220 ft. would give the profile for loose earth work to be done in each layer. This is shown in the Fig 2(a) where the broken lines shown the proposed final embankment & thin firm lines show the first layer of loose earth work. Uniform spreading of earth in between shall be ensured by longitudinal strings.

16.1.5 After first layer is rolled to layer 1-1, the profile for the second layer will be similarly fixed by typing to the horizontal string 9" above the compacted layer & refixing the small pegs K1 K2 at about 30" from the poles A&B (Fig. 2(b)).

16.1.6 Profiles or further layers will similarly fixed as shown in Fig.2(c).

16.1.7 The sub-grade soil i.e. the layer 2" to 12" below the road crust, may be of imported soil if approved in the estimated & for this reason, it is necessary that the top most layer made of local earth i.e. earth from the adjoining borrow pit should be made true to the final required profile & camber. This would result in providing uniform thickness of imported soils which is normally expensive. This should be checked by templates. The standards of compaction of the 1<sup>st</sup>. two layers will be more rigid.

16.1.8 The top most layers below the pavement (road crust) shall be very carefully done till the final profile & tolerances required in the specifications are obtained. These should be again checked with templates.

This layer will be laid when road crust is almost ready to be put on. The standard of compaction as well as finished shall be stricter & most rigid.

16.1.9 Above the sub-grade the formation of the road crust (soling or base course metal consolidation etc.) shall proceed simultaneously with the side.

16.2 No box for providing road crust is permissible when part embankment has been done earlier.

16.2.1 When earth work was done before but not up to the full formation height & specially inadequately compacted, the sequence of work is as explained below & shown diagrammatically in Fig. 3 (a) to (c) enclosed.

16.2.2 Poles at the toe line & at edges, shall be fixed as shown in Fig (a). The top of the existing earth work shall be put to depth 1' – 6" to 2'-0" & earth spreading in the usual layer or thickness to the sides to form the slope & the sides & adequately compacted at OMC, thus forming horizontal top surface. The top layer shall therefore be rolled to the required compaction at OMC etc. & further earth work done as explained in sketches Fig.2(b) to 2(c).

**16.3 OPERATION WHEN THE EXISTING EARTH WORKS NEARLY UPTO THE FORMATION LEVEL.**

16.3.1 Where the existing earth work is nearly up to the full formation level & not adequately compacted, the pegs & poles shall be fixed at the toe lines & at the edge lines of the formation width to which strings tied would indicate the profile. In such case the formation level shown in the sanctioned drawings shall be taken to the level of top of sub-base over with additional thickness or crust inclusive of any sub-base stabilized soil etc. is to be added. Top 6" to 9" layer of earth work should be scrapped & this earth should be used to build up the side & the slopes.

This thickness may be increased at the discretion of the Superintending Engineer where compaction is very poor or where bad work is to be rectified.

The next 9" to 12" layer at the top should be properly compacted to the required degree of compaction.

16.3.2 Further layers as necessary should then be added as indicated in sub-para 2.2

**17 TENTATIVE SPECIFICATION FOR BITUMINOUS MACADAM (BASE & BINDER COURSE)**

**17.1 DESCRIPTION :**

Bituminous macadam shall consist of the construction of one more course or compacted crushed aggregates premixed with a bituminous binder, laid immediately after mixing.

It is an opened graded construction suitable for base & binder course & should not be used as a wearing courses, as such it may be used a temporary riding surface when covered with an appropriate seal coat.

**17.2 MATERIALS:**

17.2.1 Bituminous Materials: The bituminous materials shall conform to the requirements as specified & provided for in the proposal & satisfy the related specification of ISI standard 72,215,217 & 454. The grades of binder to be used would depend upon the climatic conditions. Paving bitumen of 30/40, 60/70 & 80/100, penetration road tars of grade RT-4, approved cut backs or emulsions are normally suitable for the bituminous macadam.

For the tack coat RT-3 or 80/100 bitumen or approved cut back or emulsions are suggested.

**17.2.2 AGGRAGATES**

The aggregates shall consist of crushed stone, crushed slag crushed gravel. Shingle or other stones as specified. The aggregate shall have clean, strong durable & fairly cubical fragments free from disaggregated pieces, organic & other deleterious matter & adherent coatings. The aggregates shall preferably be hydrophobic or of very low porosity.

17.2.2.1 PHYSICAL REQUIREMENTS: The aggregates shall satisfy the following physical requirements.

	<u>Base Course</u>	<u>Binder Course</u>
Aggregate Impact Value Maximum	35 %	30%
Los Angles Impact Value Maximum	50%	40%

CONTRACTOR

For slag weight shall not be less than	1220 KG./ PER CCM (70lb/cu.Ft.)
Loss site sodium soleplate for five cycles maximum	12%
Flakiness index Maximum	15%
Striping test (CRRI) Maximum	25%

Where all or some of those conditions can not be satisfied, it is left to the Engineer-in-Charge to allow reasonable variations.

The use of low grade aggregate by improving their qualities shall also be considered.

17.2.2.2 GRADING OF AGGREGATES: The aggregates for the bituminous macadam for different thickness shall conform to the grading given in Table 1 & 2.

TABLE- 1: 75 MM. (3 in) compounded thickness

Sieve designation ( IS)	Percentage by weight passing sieve
45 mm.	100
26.5 mm.	75-100
22.4 mm.	60-95
11.2 mm.	30-55
5.6 mm.	15-35
2.8 mm.	5-20
90 micron	0-5

TABLE- 2: 50 MM. (2 in) compounded thickness

Sieve designation ( IS)	Percentage by weight passing sieve
26.5 mm.	100
22.4 mm.	75-100
11.2 mm.	50-85
5.6 mm.	20-40
2.8 mm.	5-20
90 micron	0-50

17.2.2.3 The binder content for premixing shall be 4 pc weight of the total mix except when otherwise directed by the Engineer-in-Charge.

The quantities of aggregates to be used shall be sufficient to yield the specified thickness after compaction.

17.3 QUANTITIES OF MATERIALS REQUIRED FOR 10 MM (100 SQFT.) OR ROAD SURFACE

17.3.1 AGGREGATES: The approximate quantity of aggregates required in ccm for 10 mm. (100 sqft.) of bituminous macadam should be 0.06 to 0.75 cum (20 to 25 cuft.) & 0.90 to 1.10 cum (30-35 cuft.) for compact thickness of 50mm. (2") & 75 mm. (3") respectively.

17.3.2 TACK COAT: If & when required the quantities of binder needed for the tack coat shall be between 5 to 7.5 kg. per 10 sqm. (10-15 lbs for 100 sqft.) for bitumen treated surface & 7.5 to 10 kg. per 10 sqm. (15-20 Lbs for 100 sqft.) for untreated water bound macadam surface.

18 CONSTRUCTION MERTHODS:

18.1 Weather & seasonal limitations: Bituminous macadam shall not be laid or placed during rainy weather or when the sub-grade or base course is damp or wet unless emulsion is used or normally when the atmospheric temperature in the shade is 160C (600F) or below.

18.2 EQUIPMENT: All equipment necessary for the proper constn of work shall be on the site of the work in good condition.

18.3 ARRANGEMENT FOR TRAFFIC: Adequate provisions for the movement of traffic shall be made as far as possible so as not to interfere with constn operation on the road.

18.4 PREPARATION OF UNDER LYING COURSE: The under lying course on which bituminous macadam is to be laid shall be prepared shaped & conditioned to a uniform grade & section as specified. Any depressions or pot holes should be properly made up & thoroughly compacted sufficiently in advance. The surface of the underlying course shall be thoroughly swept & scraped clean & from dust & foreign materials.

18.5 APPLICATION OF TACK COAT: The binder shall be heated to its appropriate application temperature except in case of emulsions & applied to the base at the rate give in para 21.3.2. It is preferable to use a sprayer but if it is not available, pouring may be used. The binder shall be applied uniformly.

The tack coat shall be applied just ahead of spreading of permitted macadam.

18.6 PREPARATION OF PREMIX: Mechanical mixers shall be used for mixing the aggregate & the bitumen binder. Improved hand mixing drums may be used only with the approval of the Engineer-in-Charge.

The bituminous materials except emulsions shall heated to the appropriate application temperature in tank so designed as to avoid local over heated & provide a continuous supply. The aggregates shall be dry & suitably warm or heated as required before it is paced in the mixer except in the case or emulsions. When it is delivered to the mixer it shall be at a temperature which is consistent with proper mixer & laying.

After about 15 seconds of dry mixing the hot bituminous materials shall be distributed over the aggregate at the rate specified in Table-1&2 & para mentioned above & at the temperature as directed by the Engineer-in-Charge with tolerance or plus of minus 100 C. The mixing shall be continued till homogeneous mixture is obtained in which all particles of the aggregates are coated uniformly.

The mixtures shall be transported from the mixing plant to the point of use in suitable vehicles or wheel borrows.

18.7 SPREADING : The mix shall be spread immediately after mixing properly by mechanical pavers, spreaders or grades. Manual spreading shall be done only with the approval of the Engineer-in-Charge with rakes to the desired thickness & to the correct camber. Uneven areas shall be brought to camber.

18.8 ROLLING : As soon as sufficient length of bituminous macadam has been laid rolling shall be done by 8 to 10 ton power rollers. Rolling shall commence at the edges, progress towards the centre longitudinally except that in super elevated curves where rolling shall progress from the lower to the upper edge parallel to the centre line of the pavement & uniformly lapping each preceding track until the entire surface has been rolled & all roller marks are eliminated & no more compaction or crushing of aggregates takes place. The roller wheels shall be kept damp.

When the roller has passed once over the whole area any high spot or depressions which become apparent shall be corrected by removing or adding fresh mixture.

The edge along & transverse of the macadam laid & compacted shall be cut full depth so that the exposed face shall be pained with thin such coat of appropriate binder before the mix is placed against it.

18.9 FINISHED SURFACE: The compacted surface shall be uniform & conform of the lines, grades & typical cross section indicated on the plans & shall present a satisfactory surface. When tested with a template & straight edge, the finished surface shall show no variation greater than 6mm. (1/4") over 3m. (10ft.) length.

## 19 RECOMMENDED PRACTICE FOR 2 CM THICK BITUMEN & TAR CARPETS.

INTRODUCTION: For all purposes, Metric Units invariably should be used. Figures given in brackets in foot point units are only approximate.

SCOPE: This recommended practice is for laying 2cm. (3/4") thick bitumen & tar carpets. The type & grade of binder is left to the discretion of the Engineer-in-Charge, so as to be in conformity with climatic, traffic & terrain condition & based on past successful practices.

### A. TWO CM THICK BITUMEN CARPET:

#### A.1. MATERIALS.

A.1.1. BINDER : The binder shall be one of the following.

(i) a straight run bitumen of suitable penetration grade complying with IS 73-1961.

(ii) a cut back bitumen of suitable viscosity complying with IS 217-1961 or IS 454-1961 or other approved cut back.

A.1.2. Coarse Aggregates: The aggregates shall consist of angular fragments & be clean, hard, tough, durable & of uniform quality thought out. They shall be crushed granite rock, gravel, river shingle or slag & should be free of elongated or flaky pieces, soft & disintegrated material, vegetable & other deleterious matter. The aggregates shall also satisfy the following properties.

	Property	Value	Method Test
	1	2	3
1	Abrasion value, using loss angle machine or Aggregate impact value	Max. 35%  Max 35%	IS: 2386 (Part-IV)  IS: 2386 (Part-IV)
2	Flakiness index	Max 23%	IS: 2386 (Part-I)
3	Stripping value	Max 25%	CRRI *
4	Water absorption (except in case of slags)	Max 10%	IS: 2386 (Part-III)
5	Soundness, loss with sodium sulphate 5 cycle (in case of slag only)	Max 12%	IS: 2386 (Part-V)
6	Unit weight or bulk density (in case of slag only)	Max 1120 kg. per ccm (70 Lbs per cut ft.)	IS: 2386 (Part-iii)

Uncrushed & rounded river gravel or shingle can also be used but the quantity of binder would be different in their case from that given under para A-2. Where such rounded aggregate are used it may be necessary to add sufficient quantity of coarse sand & an appropriate quantity of hot bitumen to make the mixture suitable for which purpose such a mix will have to be designed for binder content depending on individuals.

#### STATE WATER IMMERSION TEST, CRRI

This test is used for a qualitative estimation of stripping of binder from a freshly coated aggregates in the presence of water. This is carried out with clean & dry aggregates & binders like penetration grade bitumen, fluxed bitumen as well as road tar.

300-400 grams of aggregates of size passing 25mm. (1") sieve & retained on 12.5 mm. (1/2") sieve are mixed with 5% binder by weight of aggregates, the conditions for mixing being as specified which, for example normally at a temperature of 120°C to 150°C or 100°C- 110°C respectively for the aggregate & road tar of grade R.T. 3 after complete coating, the mixture is allowed to cool to room temperature in a clean dry beaker. Distilled water is then added to immerse the coated aggregate. The beaker is covered & kept undisturbed in a thermostatic water bath at a temperature of 40°C (104°F) for a period of 24 hours. The extent of stripping is then evaluated while the specimen is under water in the beaker & after cooling it to room temperature & expressed as the average percent in area of aggregate surface uncoated.

\*\* In the absence of proper design facilities, the proportion of sand to be added may be worked out as under.

One cubic foot wooden box is filled to the top with gravel & weight after repeated shaking to allow for more gravel to be added. The coarse sand which is proposed to be used is added on to this box & robbed so as to allow for as much coarse sand as possible to get in the voids of the gravel. The top is then struck off & the box is weighed again, these two weightings give the proportion of sand to be added with proportion, suitable & gravel bituminous mixtures are made with varying bitumen contents from 4 to 6 percent by weight & tested for strength. That binder content which gives maximum strength of stability is the bitumen content to be used.

A.1.3. **Fine aggregates or sand:** The fine aggregates or sand shall consist of clean, hard durable, uncoated coarse dry particles & be free from injurious amounts of dust soft or flaky particles or organic matter or other deleterious substances.

A.2 QUANTITIES OR MATERIALS REQUIRED.

A.2.1 Aggregates

A.2.1.1 For carpet

	<u>Per 10 mm of Road surface</u>	<u>Per 100 sqft of road surface</u>
(a) Stone chippings 13.2mm. size passing 22.4mm. Sieve & retained in 11.2mm. sieve	0.18 ccm	6 cft.
(b) Stone chippings 11.2 mm. size, passing through 13.2mm/ sieve & retained on 5.6mm. sieve	0.09 ccm	3 cft.
	-----	-----
	0.27 ccm.	9cft.
A.2.1.2 For seal coat.		
(c) Liquid seal coat: crushed fine aggregates 6.7mm. Size passing through IS 9.5mm.	0.06 ccm	2 cft.
(d) Premix seal coat: coarse sand or stone grit passing IS 2.36mm. sieve retained on 180 micro sieve	0.06 ccm	2 cft.

---

\* In case emulsions are used, the quantity will be 50%

A.2.2 BINDER

Per 10 mm. of road surface

A.2.2.1 FOR TACK COAT

(a) On water bound macadam	6.5 to 7.5 kg.
(b) On existing black top surface	4.5 to 5.5 kg.

Note: For emulsions complying with IS 3117-1955, the same quantities as given above may be used. In case the existing black top surface which is extremely rich in binder or fatty. The tack coat be eliminated in hot climatic regions at the discretion of the Engineer-in-Charge if a good bond between the existing surface & the super imposed layer can be ensured.

A.2.2.2 For premixing

(a) For 0.18 ccm of 13.2mm. size stone chippings @ 52 kg. per ccm.	9.5 kg.
(b) For 0.09 ccm. Of 11.2mm. size stone chippings @ 56 kg. per ccm.	<u>5.1 kg.</u> 14.6 kg.

A.2.2.3 For seal coat.

(a) Low rainfall areas (under 150 cm. per year)	6.8 kg.	15 Lb.
(b) High rainfall areas (over 100 cm per year)	9.8 kg.	20 Lb

A.3 **CONSTRUCTION**

A.3.1 **PREPARATION OF BASE:** Before the carpet is applied to the existing base the road must be free from dust or caked mud; where the existing base is pot-holed or rotted, these irregularities must be corrected with premixed chips or coated macadam, depending upon the depth of the pot hole, laid after applying a tack coat of binder & well rammed thereafter. Where the existing base is extremely porous & absorptive, a suitable primer (vide IRC Tentative specification for priming of base course with bituminous primers) shall be applied. The surface should be cleaned by:-

- (a) Removing caked earth & other foreign matter with wire brushes.
- (b) Sweeping with brooms &
- (c) Dusting with sack.

A.3.2 **TACK COAT:** The binder should be heated, wherever required to the appropriate temperature as indicated by the manufacturer & applied to the base at the rate specified in. It is best to use a sprayer. The binder should be evenly brushed, if needed. If the emulsions are used, quantity required will be 50% of what is indicated. The tack coat should be applied just ahead of the spreading of the premix.

A.3.3 **PREPARATION OF PREMIX:** Mechanical mixer should be preferred. When only improved hand mixing drums are available for premixing, place 0.028 ccm (1cft) of 12.5 mm. (1/2") chippings & 0.01 ccm (1/2 cft) of 10mm. (3/8") chipping in the mixing drums & mix dry thoroughly. The aggregates should be suitably heated prior to the adding of bitumen.

And 2.24 kg. (5 Lb) of the binder as per quantities given in para A.2.2 heated where required to a temperature suitable to the grade of bitumen used & mix until the chippings are thoroughly coated with the binder.

Empty the premix on to the stretcher or wheel barrows & carry to site. The quantities of chippings & binder per batch as given may be proportionately increased if proper coating is possible in one operation.

A.3.4 **SPREADING PREMIX:-** Immediately after applying the tack coat spread the premix with rakes to the desired thickness & camber or distribute evenly by means of a drag spreader, check camber by means of a camber board & even out inequalities.

A.3.5 Rolling as soon as sufficient length say 15 mtr. of the premix have been laid rollers should commence with smooth wheeled rollers (6 to 9 tonnes) or pneumatic tired rollers. Rolling should commence at the edges & progress towards the centre longitudinally except in the case of superheated sections where this should commence at the inner edge & proceed towards the outer edge of the curve.

When the roller has passed once over the whole area any high spots or depressions. Which becomes apparent should be corrected by removing or adding premixed chipping. Where this has been done, roll to compaction. Avoid excessive rolling as this serves no useful purpose & may spoil the carpets.

Moist the roller wheel to prevent the premix from a adhering to the wheels & being picked up.

A.3.6 **APPLICATION OF SEAL COAT:** In low rainfall areas, i.e. those having under 150 cm. (60") per year a premixed sand seal coat mixed preferably in a mechanical mixer after heating the same should be applied immediately & rolled. Materials required for this seal coat are given in paras A2.1.2 & 2.2.3.

In high rainfall area, i.e. those having rainfall over 150 cm. (60") per year a seal coat preferably with stone chippings mixed with coarse sand can be used & should be applied after laying of the carpet. The binder heated to the permitted temperature should be applied to the cleaned surface, blinded with chipping & rolled.

Materials required are given in para A.2.2.3

The finished surface shall be uniform & conform to the lines, grades & typical cross sections specified. When tested with a template & straight edge, the finished surface shall not show variation greater than 6.3mm. (1/4") over a 3m. (10ft.) length.

A.4. **OPENING TO TRAFFIC:** Traffic may be allowed on the road preferably 24 hours after providing the seal coat. This should be considered the minimum period when cut back or emulsion is used.

**B. TWO CM. THICK TAR CARPET**

**B.1. MATERIALS:**

B1.1 **BINDER:** The binder shall be road tar or grade RT 3 or RT4 (No. IS: 215-1961).

B.1.2 **COARSE AGGREGATES:** The aggregates shall consist of angular fragments & be clean hard, tough, durable & of uniform quality throughout. They shall be crushed rock, gravel, river shingle or slag & should be free of elongated or flaky pieces, soft & disintegrated materials & other deleterious matter. The aggregates shall satisfy the following properties.

	Property	Value	Method Test
	1	2	3
1	Abrasion value, using loss angle machine or Aggregate impact value	Max. 35% Max 35%	IS: 2386 (Part-IV) IS: 2386 (Part-IV)
2	Flakiness index	Max 23%	IS: 2386 (Part-I)
3	Stripping value	Max 25%	CRRRI *
4	Water absorption (except in case of slags)	Max 10%	IS: 2386 (Part-III)
5	Soundness, loss with sodium sulphate 5 cycle (in case of slag only)	Max 12%	IS: 2386 (Part-V)
6	Unit weight or bulk density (in case of slag only)	Max 1120 kg. per ccm (70 Lbs per cut ft.)	IS: 2386 (Part-iii)

- B.1.3 Fine aggregate or sand as in para A.1.3
- B.2. **QUANTITIES OF MATERIALS REQUIRED**
- B.2.1 **Aggregates**
- B.2.1.1 For carpet:

	<u>Per 10 mm of Road surface</u>	<u>Per 100 sqft of road surface</u>
Stone chippings 13.2mm. size passing 22.4mm. Sieve & retained in 11.2mm. sieve	0.18 ccm	6 cft.
Stone chippings 11.2 mm. size, passing through 13.2mm/ sieve & retained on 5.6mm. sieve	0.09 ccm	3 cft.
	<hr style="width: 100%;"/>	<hr style="width: 100%;"/>
	0.27 ccm.	9cft.
Coarse sand or stone graft, passing 2.36 mm. Sieve & retained in 180 micro sieve	0.060 ccm	2 cft.

B.2.2 **BINDER**

- (a) For premixing coat on water bound macadam surface
  - (b) For low porosity surface
  - (c) For medium porosity surface
  - (d) For high porosity surface
  - (e) For tack coat (on an existing black topped surface)
  - (f) For seal coat
  - (g) For premixing
- |  |  |
|--|--|
|  | 7.3 to 9.8 kg.                           |
|  | 8.9 to 12.2 kg.                          |
|  | 12.2 to 14.6 kg.                         |
|  | 7 kg to 10 kg (15 to 20 lb)              |
|  | 9.8 kg. (20 lb)                          |
|  | 19.6 kg. (40.5 lb @<br>@ 4.5 lb) per cft |

B.3. **CONSTRUCTION**

B.3.1 Preparation of base : As in para A.3.1.

B.3.2. Tack coat: The binder should be heated to 105°C/ (220°F to 240°F) & should be applied at the rates specified in para B.2.2. to 1/5°C

It is best to use a sprayer. The binder should be evenly brushed, if need be. The tack coat should be laid just ahead of the spreading of the premix.

B.3.3 **PREPARATION OF PREMIX:** Mechanical mixers should be preferred. When only improvised hand mixing drums are available for premixing place 0.028ccm (1 cft.) of 12.5 mm. (1/2") chippings & 0.014m. (1/2 cft.) of 10mm. (3/8") chipping in the mixing drum & mix thoroughly dry. Add 3 kg. (6.75 lb) of road tar heated to 105°C/105°C/ (220°F to 240°F) & mix until chippings, preheated if necessary are thoroughly heated with the binder. Empty the premix on to stretchers or wheel barrows & carry to site. The quantities of chipping & binder per batch may be proportionately increased if proper coating is possible in one operation.

B.3.4 **SPREADING PREMIX :** As in para A.3.4.

B.3.5 **ROLLING:** As in para A.3.5.

B.3.6 **APPLICATION OF SEAL COAT:** Immediately after laying the carpet, the seal coat should be applied in the manner detailed below.

Road tar IS grade RT.3. heated to 105°C should be spread evenly at 9.8 kg. per 10 sqm. or 20 lb per (100 sft.) & then it should be blinded evenly with medium coarse day sand as fine grit at the rate of 0.06 ccm. Per 10mm. (2 cft. Per 100 sft.)

The finished surface shall be uniform & conform to the lines, grades & typical cross sections. When tested with a template & a straight edge, the finished surface shall show no variation greater than 6.3mm. (1/4") over a 3m. (10ft.) length.

B.4. **OPENING TO TRAFFIC:**

The traffic may be allowed on the road 24 hours after providing the seal coat.

**SECTION-7  
FORMS**

## NO RELATION CERTIFICATE

Certified that I / We am / are not related to any officer of Water Resources Department of the rank of Assistant Engineer and above or any officer of the rank of Assistant Secretary above.

### CONTRACTOR

List of Relatives of the tender serving in Water Resources Department.

Sl No.	Name of the relatives	Rank	Place of present posting with office / Division / Department
1	2	3	4

- 1.
- 2.
- 3.
- 4.
- 5.

### CONTRACTOR

CONTRACTOR

**FORM – A STRUCTURE AND ORGANISATION**

Name of Tenderer.

Nationality of Tenderer. ....

Office Address. ....

Telegraphic Address ....

Telephone No: .....

Mobile No: .....

Telex Number .....

Location of establishment .....

The tenderer is

1. An individual
2. A proprietary firm.
3. A limited company or limited corporation
4. A member of a group of companies (If yes, give names, address and present description of other companies.)
5. A subsidiary of large organization

(If yes, give names, address of the present organization)

6. if the company is subsidiary, state what involvement if any, will the parent company have in the project.

Attach the organization chart showing the structure of the organization including the names of the Directors position of officer.

7. Number of year of experience

a. As a prime contractor

I. In own country

II. Other country (specify country)

b. In a Joint venture

I In own country

II Other country (specify country)

8. Name of the address of any associates the tenderer has in India who are knowledgeable in the procedure of customs, immigration takes and other information necessary to do work.

9. How many years has your organization been in business under your present name? Add what were your fields were and when you established your organization. When did you add new field (if any)?

10. Were you ever required for suspending construction for a period of more than six months continuously after you started? If so, give the names of project and reason of failure.

11. Have you ever not completed any work awarded to you? If so give name of project and reasons for not completing the work.

12. In how many projects were imposed penalties for delay? Please give details.

13. In which fields of Civil Engineering construction do you claim specialization and Interest.

14. Give details of your experience in modern concreting / Earth work and quality control.

15. Give details of your material testing laboratory.

Signature of tenderer

## FORM-B FINANCIAL STATEMENT

(Must be given separately for each partner in case of joint venture )

1. Name of Firm.
- 2 Name of partner /Directors
- 3 Capital
  - a. Authorized
  - b. Issued and paid-up
- 4 a. Details of the work completed and tenderer's performance record for last five years.( Vide Annexure-A )
  - b. Details of work on hand and tenderer's performance record for last five years.  
( Vide Annexure-B )
- 4 Furnish Balance sheet and profit & loss statement with auditor's reports for the
5. Last five years , it should include the following information.
  - i Working capital
  - ii Foreign investment.
    - a. Turnover for 2020-2021
    - b. Turnover for 2021-2022
    - c. Turnover for 2022-2023
    - d. Turnover for 2023-2024
    - e. Turnover for 2024-2025
  - iii
  - iv Gross income
    - a Turnover for 2020-2021
    - f. Turnover for 2021-2022
    - g. Turnover for 2022-2023
    - h. Turnover for 2023-2024
    - i. Turnover for 2024-2025

V Total liabilities

Current ratio.

a Current assets to current liabilities

b Total liabilities to net work.

6 What is the maximum annual value of work that you can handle ?

7 Have you ever been denied tendering facilities by any Government Department/  
Public sector undertaking ?

(Give details )

8 List your sources of finance?

a Own resources

b Bank credit.

C Other sources-specify if any?

9 Certificate of financial soundness by Bank ( To be signed by Senior manager  
of a Nationalized Bank )

10 Name and address of Bank from whom reference can be obtained.

Name :

Address :

Telephone No:

Fax No :

11 Have you ever been declared bankrupt?

(if yes , please give details)

Signature of tenderer

CONTRACTOR

## ANNEXURE – A

### FORMAT FOR PERFORMANCE RECORD OF CONTRACTORS

1. Name of the Contractor :
2. Registration No. and Date :
3. Class of Contractor :
4. Licensing Authority :
5. License valid up to :
6. Details of works executed :

Sl. No.	Jobs under execution	Agreement amount	Date of Commencement	Stipulated Date of Completion	Whether work is progressing as per programme	Reasons for delay ,if any
1	2	3	4	5	6	7

7. Whether the Contractor has requisite machineries & personnel deployed (details of machinery and personnel deployed) :
8. Whether the quality of construction is satisfactory :
9. Whether he has capability to make good the loss in time :
10. Whether the Contractor has abandoned any work in the past three years, if yes, the details thereof.
11. Whether the Contractor has entered in to any litigation in the past if yes, the details thereof.

Name of the Certifying Officer

With official seal

Signature of Contractor

CONTRACTOR

## ANNEXURE – B

Details of the works on hand and performance for last five years as on the date of submission of pre-qualification documents in the following proforma.

*( Separate form for each work )*

1. Name of work \_\_\_\_\_
2. Place and Country \_\_\_\_\_
3. Total tendered cost of work \_\_\_\_\_
4. Brief description of works including principal features and quantities of main items. \_\_\_\_\_  
\_\_\_\_\_
5. Details of works in hand
  - i. Percentage of physical completion and amount billed for the work completed.
  - ii. Cost of work remaining to be executed.
  - iii. Stipulated date of completion.
  - iv. Anticipated date of completion.
6. Explain for non-completion of work within stipulated time limit if so.
7. Were there any penalties /fines / stop notice / compensation /liquidated damages imposed ?Yes or No.  
If yes , give amount and explanations
8. Were there any fines, claims or stop notice filed by the employer ? (Yes or No.)/  
( If yes, give amount and explanation )

Signature of Tenderer

**ANNEXURE-‘E’**

**(AFFIDAVIT)**

(To be submitted in original in legal stamp paper)

I, Sri..... Aged..... year,  
Son/ Daughter/ Wife of Sri..... at present residing  
At..... P.O.....P.S.....Dist.....

Pin.....do here by solemnly affirm as follows.

i) That, I / We possess a valid license for execution of works contract issued by \*..... belongs to .....Class & is valid upto \*\*.....

I am submitting tenders before the Additional Chief Engineer, Angul Irrigation Circle, Angul for execution of “Improvement to Right Service Bank Road of Sapua Link Channel from RD 2.100 Km to RD 5.330 Km of Sapua Badjore Irrigation Project” response to ‘e’ procurement notice No.

**ACEAIC- 02 /2026-27 (On-line).**

I am the authorized signatory on behalf of contractor for the tender for the work mentioned above.

ii) I am swearing this affidavit that all tender documents and accompanying papers those being submitted by me before the Additional Chief Engineer, Angul Irrigation Circle, Angul including E.M.D. in any shape are all authentic and bonafide documents in the eyes of the law of the land.

That the fact stated in the affidavit are true to the best of my knowledge and belief.

Signature of Contractor /Authorized Signatory

Note :

\*Mention the license issuing authority.

\* \*Mention the date up to which the license is valid

**VI. CHECK LIST SUBMITTED OR NOT**

- |   |   |        |
|---|---|--------|
| 1 | Form A Structure and Organization   | Yes/No |
| 2 | Form B Financial position   | Yes/No |
|   | a) Balance sheet of last five years   | Yes/No |
|   | c) True copies of Income Tax & Sales Tax clearance certificate for the last five years for domestic contractors.        | Yes/No |
| 3 | Certificate of registration for execution of contract attached  | Yes/No |
| 4 | Documentary evidence in support of statement 4 A,B,C,D & E-a of General Statement attached.<br>(Refer Page No. 21 & 22) | Yes/No |
| 5 | Certified copy of power of attorney in case of partnership firm, limited or Corporation attached.                       | Yes/No |
| 6 | Documentary evidence as required in minimum pre-qualification criteria.   | Yes/No |
| 7 | Affidavit for authenticity of document, EMD & Tender  | Yes/No |

**Annexure-I**

**DETAILS OF OTHER WORKS TENDERED FOR AND WORKS IN HAND  
ON THE DATE OF SUBMISSION THE TENDER**

SI No.	Name of works with No. & Date of agreement & Division & Dept. concerned	Place & Country	Work in Hand			Work Tendered for			Remarks
			Tendered cost	Cost of work remaining to be executed	Anticipated date of completion	Estimated cost	Date when decision is expected	Stipulated date & period of completion	
1	2	3	4	5	6	7	8	9	10

CONTRACTOR

**DETAILS OF WORK SIMILAR TYPE AND MAGNITUDE CARRIED ON BY THE CONTRACTOR IN THE PAST**

<b>Sl No.</b>	<b>Name of works with No. &amp; Date of agreement &amp; Division / Dept. concerned</b>	<b>Place &amp; Country</b>	<b>Tendered cost</b>	<b>Time in which completed</b>	<b>Date of completion</b>	<b>Principal Features</b>
<b>1</b>	<b>2</b>	<b>3</b>	<b>4</b>	<b>5</b>	<b>6</b>	<b>7</b>

**SECTION-8  
DRAWINGS**

Name of Work : Improvement to Right Service Bank Road of Sapua Link Channel from RD 2.100 Km to RD 5.330 Km of Sapua Badjore Irrigation Project.

NOT TO SCALE

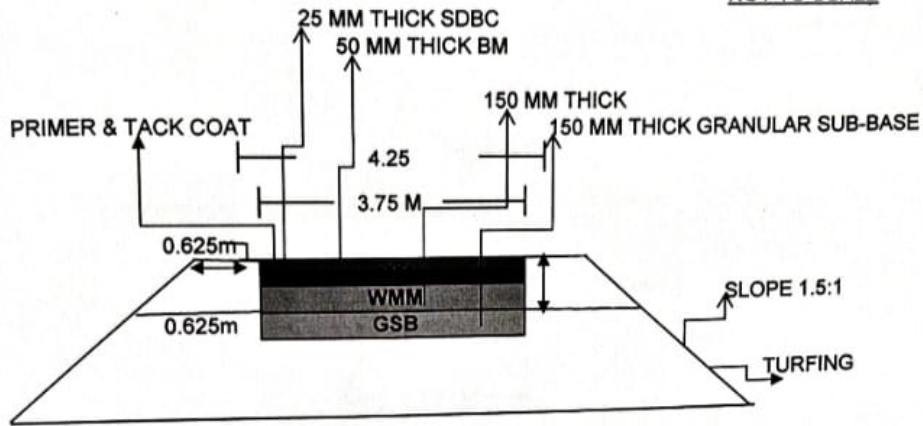

TYPICAL CROSS SECTION OF BT ROAD

*[Signature]*  
29/5/22  
Junior Engineer  
Sapua Badjore Irr. Sub-Division  
Satamile

*[Signature]*  
Asst. Executive Engineer  
Sapua Badjore Irr. Sub-Division  
Satamile

APPROVED

*[Signature]*  
29/5/22  
SUPERINTENDING ENGINEER  
ANGUL IRRIGATION DIVISION  
ANGUL

Name of Work : Improvement to Right Service Bank Road of Sapua Link Channel from RD 2.100 Km to RD 5.330 Km of Sapua Badjore Irrigation Project.

NOT TO SCALE

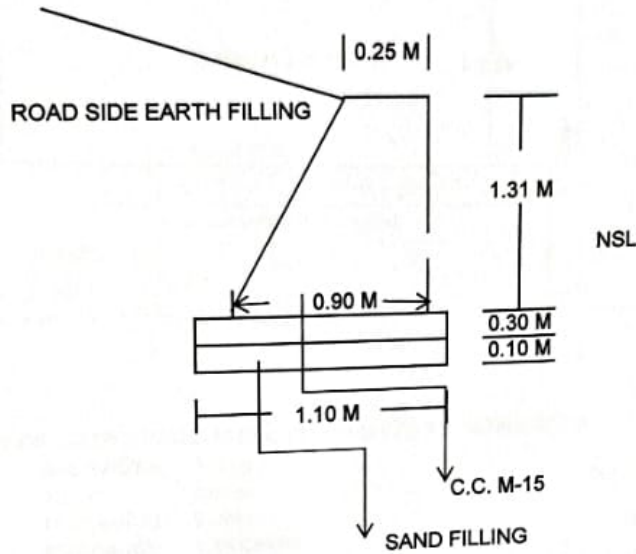

TYPICAL SECTION OF TOE WALL

*[Signature]*  
29/05/26  
Junior Engineer  
Sapua Badjore Irr. Sub-Division  
Satamile

*[Signature]*  
10/05/26  
Asst. Executive Engineer  
Sapua Badjore Irr. Sub-Division  
Satamile

APPROVED

*[Signature]*  
29/5/26  
SUPERINTENDING ENGINEER  
ANGUL IRRIGATION DIVISION  
ANGUL